

# HYDAC

# INTERNATIONAL

## Inline Filter RFL

Welded version, Steel / Stainless steel  
Flow rates up to 15,000 l/min \*  
Pressure range 16 bar

RFL inline filters are designed for inline mounting in hydraulic and lubrication systems.

\* For flow rates up to 1300 l/min, please see brochure: RFL Inline Filter, Cast Version

## 1. TECHNICAL DESCRIPTION

### 1.1. FILTER HOUSING

#### Construction

The filter housing is designed according to international regulations.

The filter consists of a housing with welded connection flanges and a stand. The inlet and outlet are positioned at different heights on opposite sides.  
(Optionally: inlet and outlet can be on the same side).

Vent, drain and clogging indicator ports are available as standard.

Filters in the series 1320, 2520...15020 correspond in design to the series 1300, 2500...15000 with twice the element withdrawal height.

A considerably larger contamination retention capacity and higher permissible flow rate are therefore achieved with otherwise identical overall dimensions.

### 1.2. FILTER ELEMENTS

Hydac filter elements fulfil all ISO test criteria.

**Reliable filter operation is only guaranteed for original Hydac filter elements.**

The filter elements are also suitable for dynamic conditions due to their high pressure stability; max permissible  $\Delta p$  across the element:

Betamicon® (BN3HC)	: 25 bar
Paper (P/HC)	: 10 bar
Wire mesh (W/HC)	: 30 bar
Stainless steel fibre (V)	: 30 bar
Betamicon®/Aquamicron® (BN/AM)	: 10 bar
Aquamicron® (AM)	: 10 bar

#### Fluid compatibility

Suitable for mineral oils, lubrication oils, non-flam fluids, synthetic and rapidly biodegradable fluids.

For use with water, please contact our sales/technical department.

For further details on filter elements, please see **brochure, no.: E 7.200../..**

### 1.3. CLOGGING INDICATORS

Clogging indicators are fitted separately as standard.

For further details on clogging indicators, please see **brochure, no. E 7.050../..**

### 1.4. SEALS

Perbunan (= NBR) or Viton (= FPM for HFD oils).

### 1.5. SPECIAL MODELS AND ACCESSORIES

- Drain and vent ports with ball valves or other shut-off valves
- Mating flanges available for all sizes
- Other sealing materials
- Venting line with sight glasses  $\Rightarrow$  visual control
- Flanges to DIN 2501 with O-ring seals
- Cover plate lifting device

### 1.6. SPARE PARTS

Please see Spare Parts List and Maintenance Instructions – **brochure no. E 7.104.E../..**

## 2. GENERAL

### Mounting

Filters must be flexibly mounted and not fixed rigidly to the floor or used as a pipe support.

**Temperature range**  
-10 °C to +100 °C

**Pressure setting of the inline clogging indicator**

$\Delta p_a = 2 \text{ bar} - 0.2 \text{ bar}$

Other pressure settings on request

**Cracking pressure of the bypass valve**

$\Delta p_o = 3 \text{ bar} + 0.5 \text{ bar}$   
optionally 1 or 6 bar

Other cracking pressures on request

### Symbol for hydraulic systems

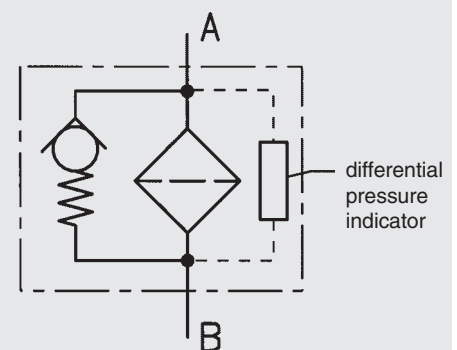

### Symbol for process engineering systems

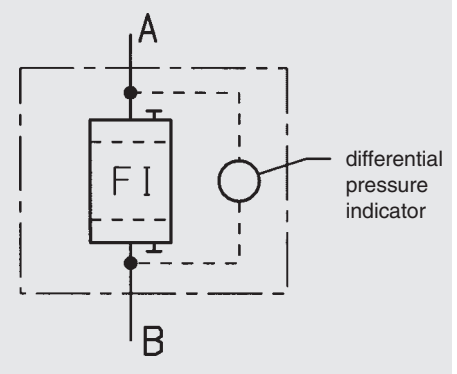

When used in lubrication systems, the filter is installed before the bearing.

### 3. MODEL CODE

(also order example)

#### 3.1. COMPLETE FILTER

RFL BN/HC 1300 C K 10 D 1 . X /-L24

Filter type \_\_\_\_\_

Filter material of element \_\_\_\_\_

BN/HC Betamicron® (BN3HC)  
 AM Aquamicon®  
 BN/AM Betamicron®/Aquamicon®  
 P/HC Paper  
 W/HC Stainless steel wire mesh  
 V Stainless steel fibre

Size \_\_\_\_\_

Steel, welded: 1300/ 1320/ 2500/ 2520/ 4000/ 4020/ 5200/ 5220/ 6500/  
 6520/ 7800/ 7820/ 15000/ 15020

Stainless steel 1.4571: 1303/1323/ 2503/ 2523/ 4003/ 4023/ 5203/ 5223/ 6503/  
 6523/7803/ 7823/ 15003/ 15023

Operating pressure \_\_\_\_\_

C = 16 bar

Type and size of port \_\_\_\_\_

Type	Port	Filter size							
		1300	1320	2500	4000	5200	6500	7800	15000
		1303	1323	2503	4003	5203	6503	7803	15003
				2520	4020	5220	6520	7820	15020
				2523	4023	5223	6523	7823	15023
K	DIN DN 40	●	●						
L	DIN DN 50	●	●	●					
M	DIN DN 65	●	●	●					
Q	DIN DN 80	●	●	●	●	●			
R	DIN DN 100	●	●	●	●	●	●	●	
U	DIN DN 125		●	●	●	●	●	●	
V	DIN DN 150			●	●	●	●	●	
W	DIN DN 200				●	●	●	●	●
X	DIN DN 250					●	●	●	●
Y	DIN DN 300								●

Other sizes on request.

Filtration rating in µm \_\_\_\_\_

BN3HC, V : 3, 5, 10, 20  
 BN/AM : 3, 10  
 P/HC : 10, 20  
 W/HC : 25, 50, 100, 200  
 AM : 40

Type of clogging indicator \_\_\_\_\_

A without clogging indicator, with blanking plug  
 B with visual clogging indicator  
 C with electrical clogging indicator  
 D with visual and electrical clogging indicator  
 W no port for clogging indicator

for other clogging indicators see brochure no. E 7.050../..

Type code \_\_\_\_\_

1

Modification number \_\_\_\_\_

X the latest version is always supplied

Supplementary details \_\_\_\_\_

V FPM (Viton) seals, filter suitable for rapidly biodegradable oils and phosphate esters (HFD-R)  
 L... light with appropriate voltage (24V, 48V, 110V, 220V)  
 LED 2 light emitting diodes up to 24 volt  
 KB without bypass valve  
 B. special bypass valve cracking pressures (B1 = 1 bar, B6 = 6 bar)  
 OR O-ring groove on the DIN flange (inlet, outlet) to Rexroth standard AB 22-04  
 DH cover plate lifting device  
 33 inlet and outlet at different heights on the same side  
 RE Sealing strip E on flange (inlet and outlet): surface finish 3.6 µm

### 3.2. REPLACEMENT ELEMENT (also order example)

1300 R 010 BN3HC /-KB

**Size** \_\_\_\_\_  
0850, 1300, 1700, 2600

**Type** \_\_\_\_\_  
R

**Filtration rating in  $\mu\text{m}$**  \_\_\_\_\_  
BN3HC, V : 3, 5, 10, 20  
BN/AM : 3, 10  
P/HC : 10, 20  
W/HC : 25, 50, 100, 200  
AM : 40

**Filter material** \_\_\_\_\_  
BN3HC; V; BN/AM; P/HC; W/HC; AM

**Supplementary details** \_\_\_\_\_  
V = FPM seals, filter suitable for rapidly biodegradable oils and phosphate esters (HFD-R)  
W = NBR seals, filter suitable for oil-water emulsions (HFA, HFC) (only on W/HC, P/HC and V elements)  
KB = without bypass valve  
B. = special bypass cracking pressures (B1 = 1 bar, B6 = 6 bar)

## 4. FILTER SPECIFICATIONS

Filter type	Port	Element size	Number of elements	Filter weight [kg] with elements
1300	DIN DN 40	1300 R...	1	64.1
	DIN DN 50			64.1
	DIN DN 65			65.1
	DIN DN 80			67.1
	DIN DN 100			69.1
1320	DIN DN 40	2600 R...	1	78.1
	DIN DN 50			78.1
	DIN DN 65			79.1
	DIN DN 80			81.1
	DIN DN 100			83.1
2500/2520	DIN DN 50	850 R.../1700 R...	3	73.9 / 82.4
	DIN DN 65			70.9 / 85.4
	DIN DN 80			72.9 / 87.4
	DIN DN 100			75.9 / 90.4
	DIN DN 125			79.9 / 94.4
4000/4020	DIN DN 80	850 R.../1700 R...	5	119.5 / 145.0
	DIN DN 100			121.5 / 147.0
	DIN DN 125			127.5 / 153.0
	DIN DN 150			133.5 / 159.0
	DIN DN 200			140.5 / 166.0
5200 /5220	DIN DN 80	1300 R.../2600 R...	4	158.4 / 202.4
	DIN DN 100			160.4 / 204.4
	DIN DN 125			170.4 / 214.4
	DIN DN 150			175.4 / 219.4
	DIN DN 200			179.4 / 223.4
6500/6520	DIN DN 100	1300 R.../2600 R...	5	221.5 / 274.5
	DIN DN 125			225.5 / 278.5
	DIN DN 150			230.5 / 283.5
	DIN DN 200			245.5 / 298.5
	DIN DN 250			255.5 / 308.5
7800/7820	DIN DN 100	1300 R.../2600 R...	6	225.6 / 282.6
	DIN DN 125			229.6 / 286.6
	DIN DN 150			234.6 / 291.6
	DIN DN 200			249.6 / 306.6
15000/15020	DIN DN 200	1300 R.../2600 R...	10	476.0 / 570.0
	DIN DN 250			488.0 / 582.0
	DIN DN 300			513.0 / 607.0

## 5. FILTER CALCULATION / SIZING

The total pressure drop of a filter at a certain flow rate is the sum of the housing  $\Delta p$  and element  $\Delta p$ .

The pressure drop can be determined either with the aid of our Filter Sizing Program FSP, which is available free of charge, or by using the following graphs.

### 5.1. $\Delta P$ -Q HOUSING GRAPHS TO ISO 3968

The housing graphs apply to mineral oil with a density of  $0.86 \text{ kg/dm}^3$  and a kinematic viscosity of  $30 \text{ mm}^2/\text{s}$ .

In this case, the differential pressure changes proportionally to the density.

In each case, the  $\Delta p$  given is for the largest possible flange nominal width.

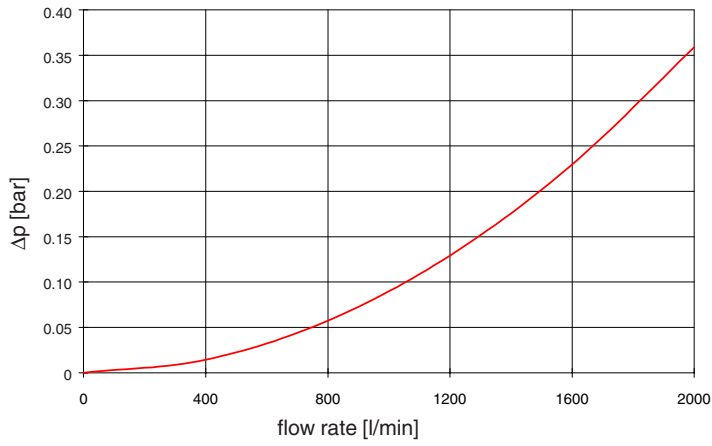
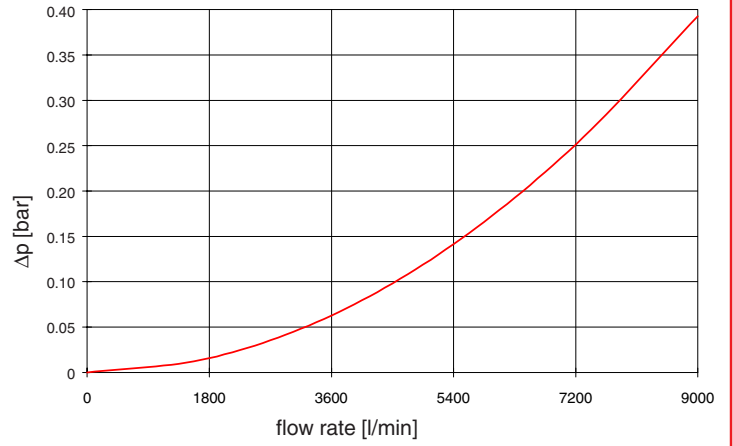
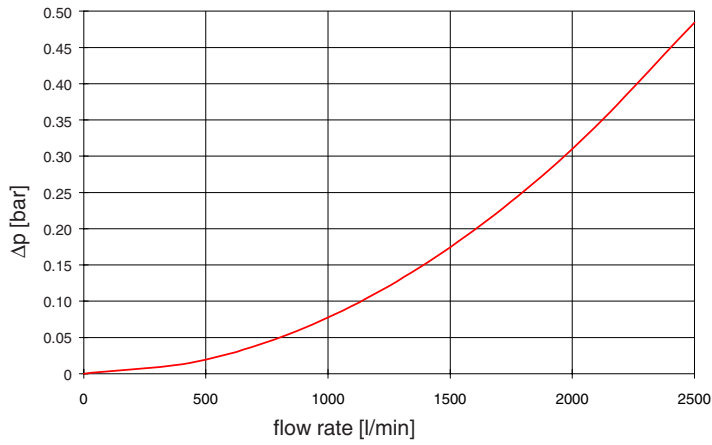
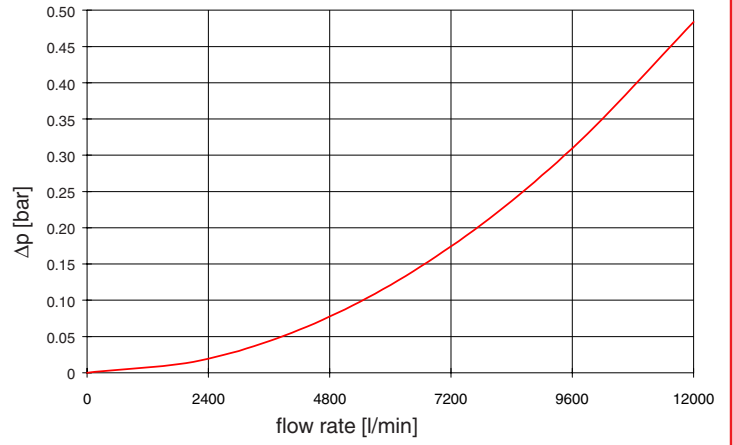
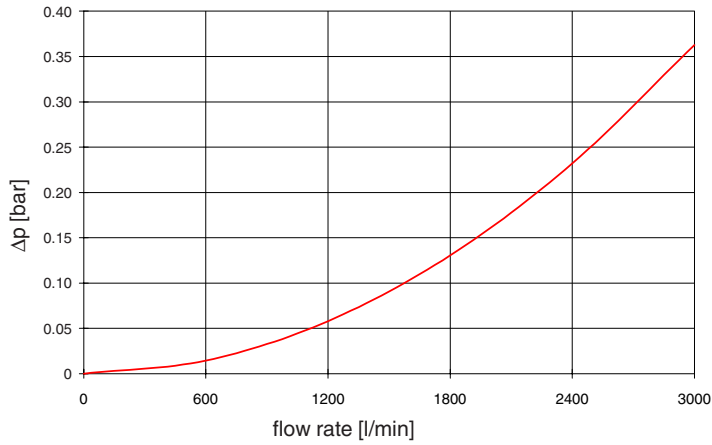
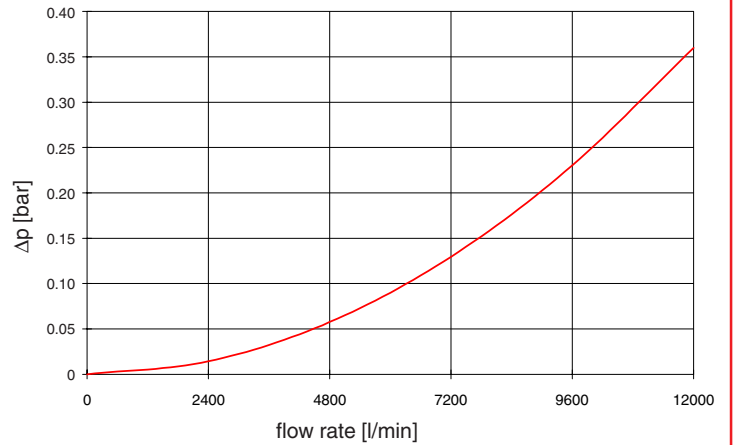
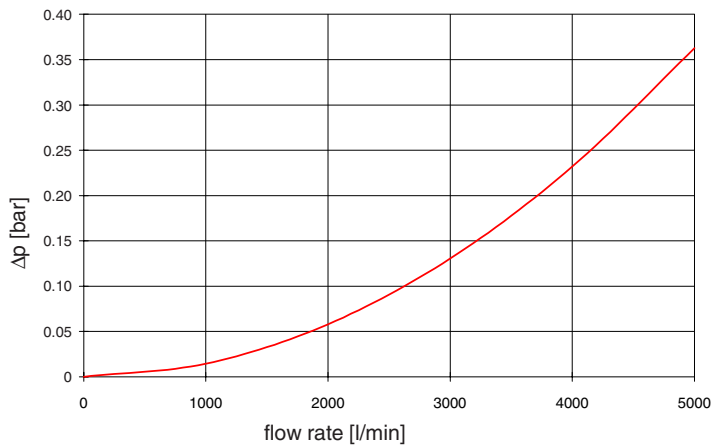
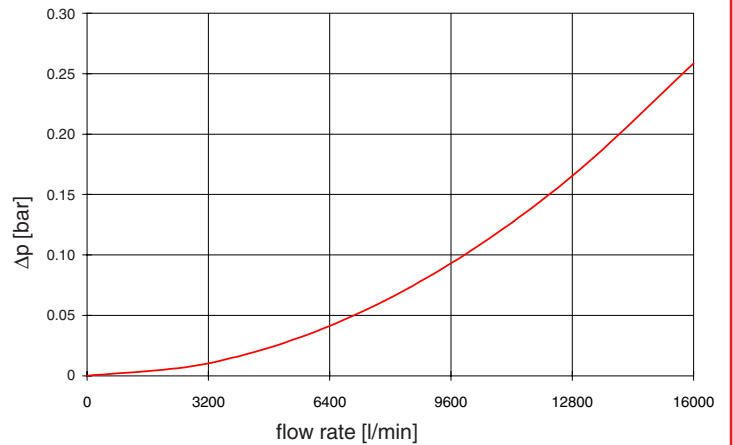
**RFL 1300****RFL 5200/5220****RFL 1320****RFL 6500/6520****RFL 2500/2520****RFL 7800/7820****RFL 4000/4020****RFL 15000/15020**

## 5.2. $\Delta P$ -Q GRAPHS – FILTER ELEMENTS

The element graphs apply to mineral oil with a kinematic viscosity of 30 mm<sup>2</sup>/s. The pressure drop changes proportionally to the change in viscosity (see Example 5.3.).

The pressure drop for each filter size across the elements at a certain flow rate Q is determined in two stages, as follows:

- 1) Flow rate Q of total filter / n = flow rate per element  
n = number of elements as given under point 4. Filter Specifications
- 2) Read off the  $\Delta p$  at the determined flow rate per element = total pressure drop across the elements for each filter size

**BN3HC: Element sizes 850 / 1300**

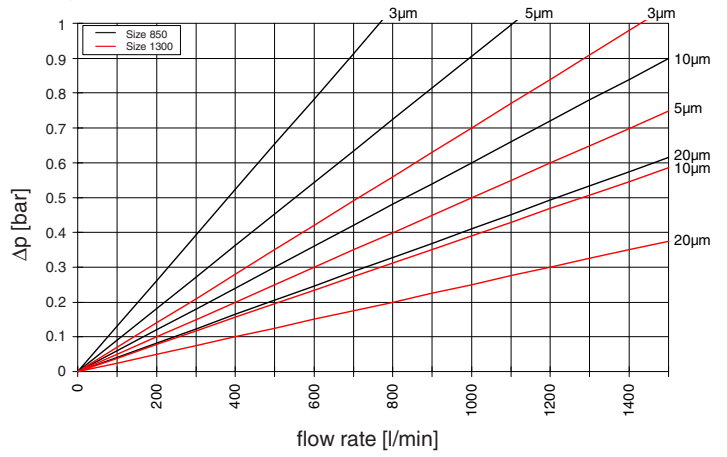

**BN3HC: Element sizes 1700 / 2600**

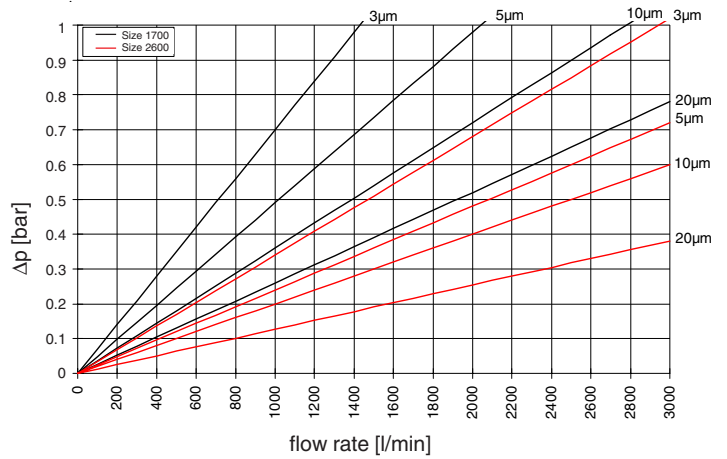

**V element: Element sizes 850 / 1300**

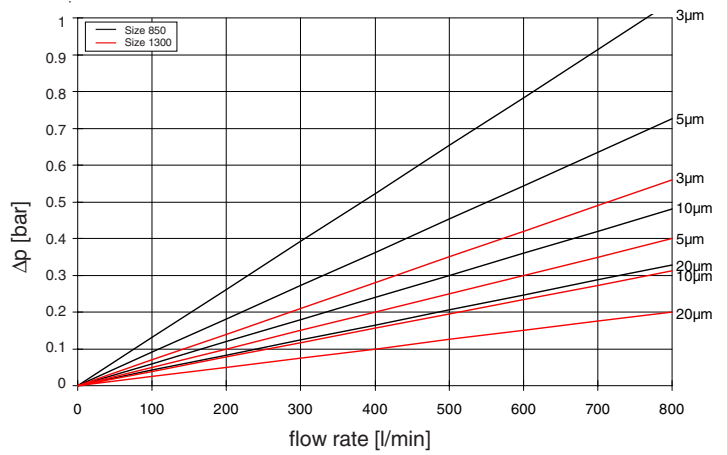

**V element: Element sizes 1700 / 2600**

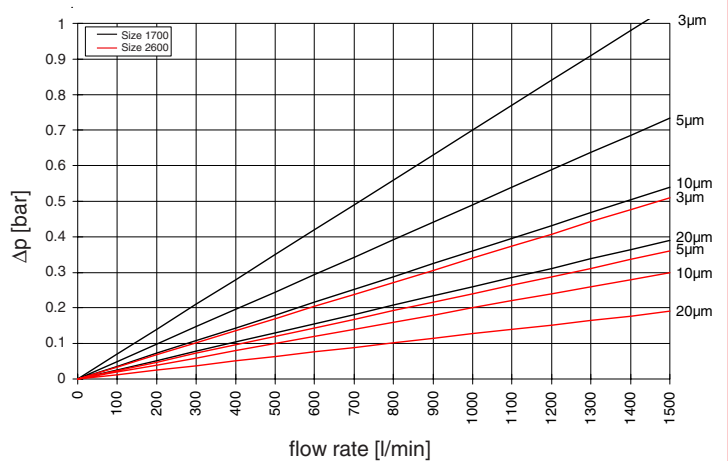

### W/HC Elements

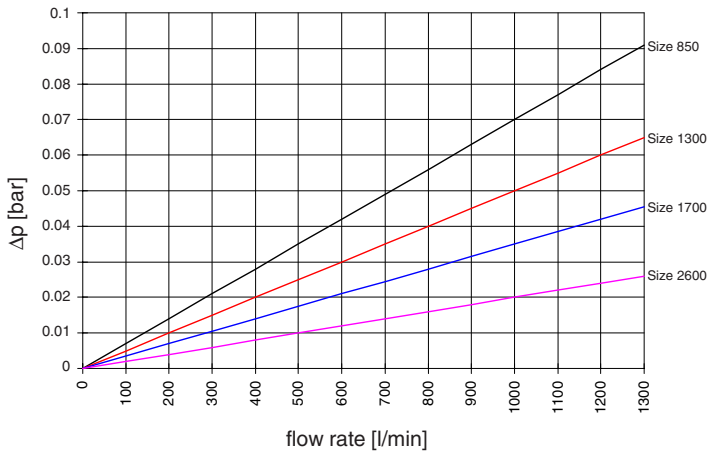

### P/HC 10μm

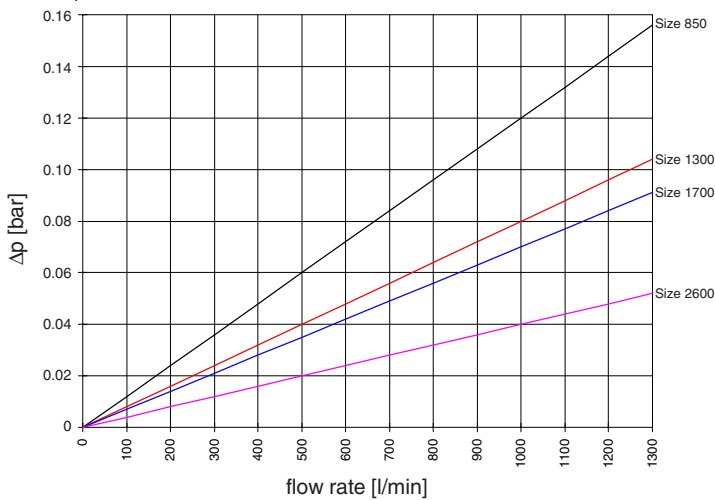

### P/HC 20μm

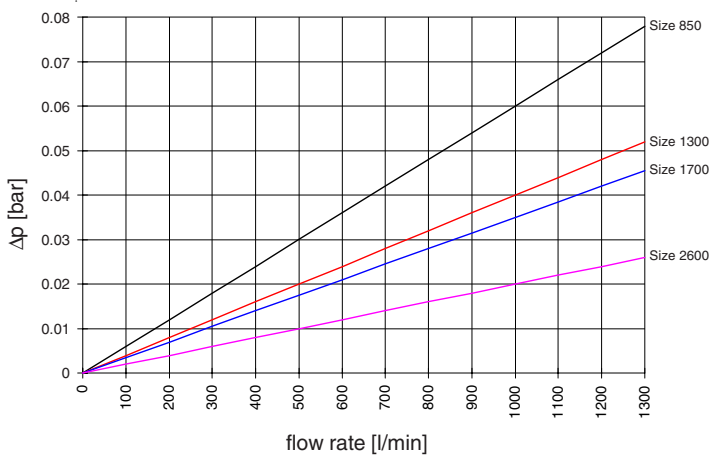

### 5.3. EXAMPLE

#### General:

$$\Delta p_{\text{total}} = \Delta p_{\text{housing}} + \Delta p_{\text{element}} \times \frac{\text{viscosity (mm}^2/\text{s)}}{30 \text{ mm}^2/\text{s}}$$

$\Delta p_{\text{housing}}$  = to be determined in accordance with Point 5.1.

$\Delta p_{\text{element}}$  = element pressure drop at flow rate Q/n and viscosity = 30 mm<sup>2</sup>/s determined according to Point 5.2.

n = no. of elements in accordance with Point 4 Filter Specifications

#### Example:

System parameters:

RFL 2520 with W/HC wire mesh element;

Viscosity = 100 mm<sup>2</sup>/s (ISO VG 100 at 40 °C)

Q = 2500 l/min; n = 3 (Size 1700)

⇒ Q/n = 833.3 l/min

⇒  $\Delta p_{\text{housing}} = 0.25 \text{ bar}$  (RFL 2520)

$\Delta p_{\text{element}} = 0.03$

$$\Delta p_{\text{total}} = 0.25 \text{ bar} + 0.03 \times \frac{100 \text{ mm}^2/\text{s}}{30 \text{ mm}^2/\text{s}} = 0.35 \text{ bar}$$

**For ease of calculation, our FSP Filter Sizing Program can be downloaded from our website: [www.hydac.com](http://www.hydac.com).**

## 6. DIMENSIONS

### 6.1. RFL 1300 - 2520

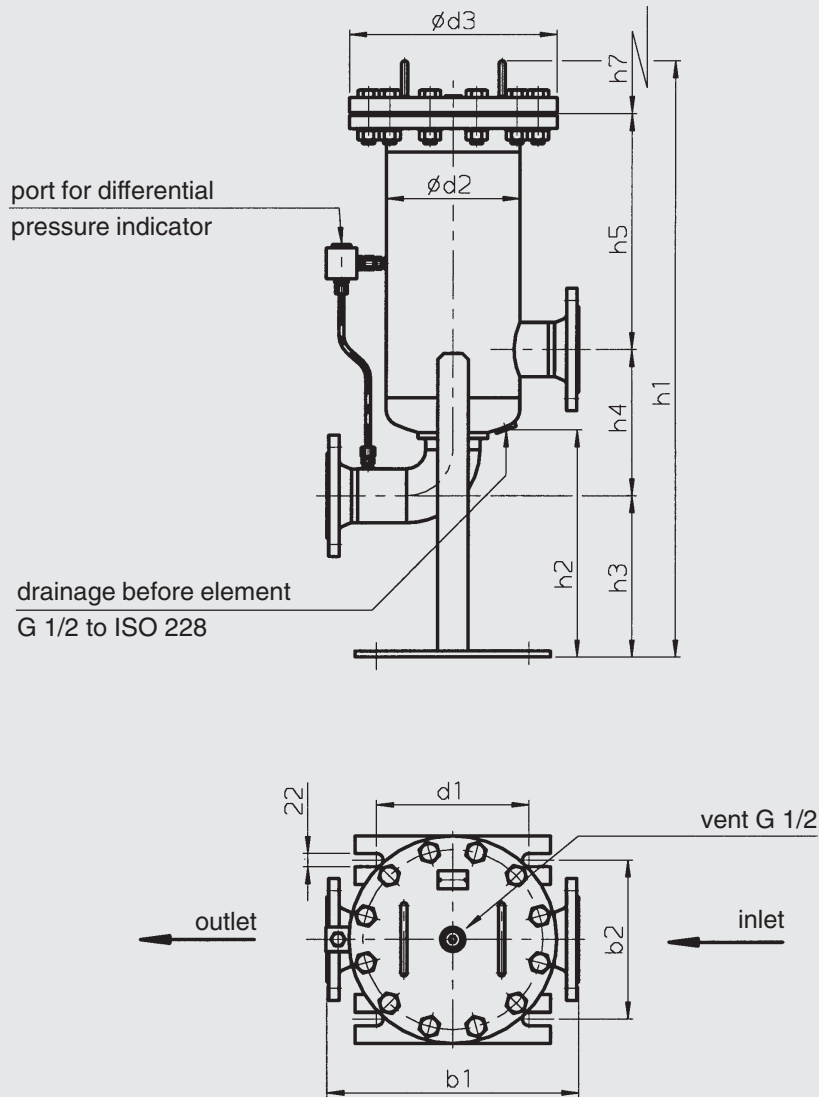

Type	Flange connection	b1	b2	d1	d2	d3	h1	h2	h3	h4	h5	h7
RFL 1300/1320	DIN DN 40	412	260	250	219.1	340	972/1416	370	294	212	384/824	500/940
	DIN DN 50	412	260	250	219.1	340	972/1416	370	266	240	384/824	500/940
	DIN DN 65	412	260	250	219.1	340	972/1416	370	279	227	384/824	500/940
	DIN DN 80	412	260	250	219.1	340	972/1416	370	266	240	384/824	500/940
	DIN DN 100	412	260	250	219.1	340	972/1416	370	253	275	362/802	500/940
RFL 1320	DIN DN 125	480	260	250	219.1	340	/1416	370	215	291	/824	/940
RFL 2500/2520	DIN DN 50	466	312	250	273	360	942/1332	220	378	270	222/612	420/810
	DIN DN 65	466	312	250	273	360	990/1380	220	408	350	160/550	420/810
	DIN DN 80	466	312	250	273	360	990/1380	220	388	410	120/510	420/810
	DIN DN 100	466	312	250	273	360	1050/1440	220	438	304	236/626	420/810
	DIN DN 125	466	312	250	273	360	1050/1440	220	438	380	160/550	420/810
	DIN DN 150	466	312	250	273	360	1050/1440	220	438	365	175/565	420/810

6.2. RFL 4000 - 15020

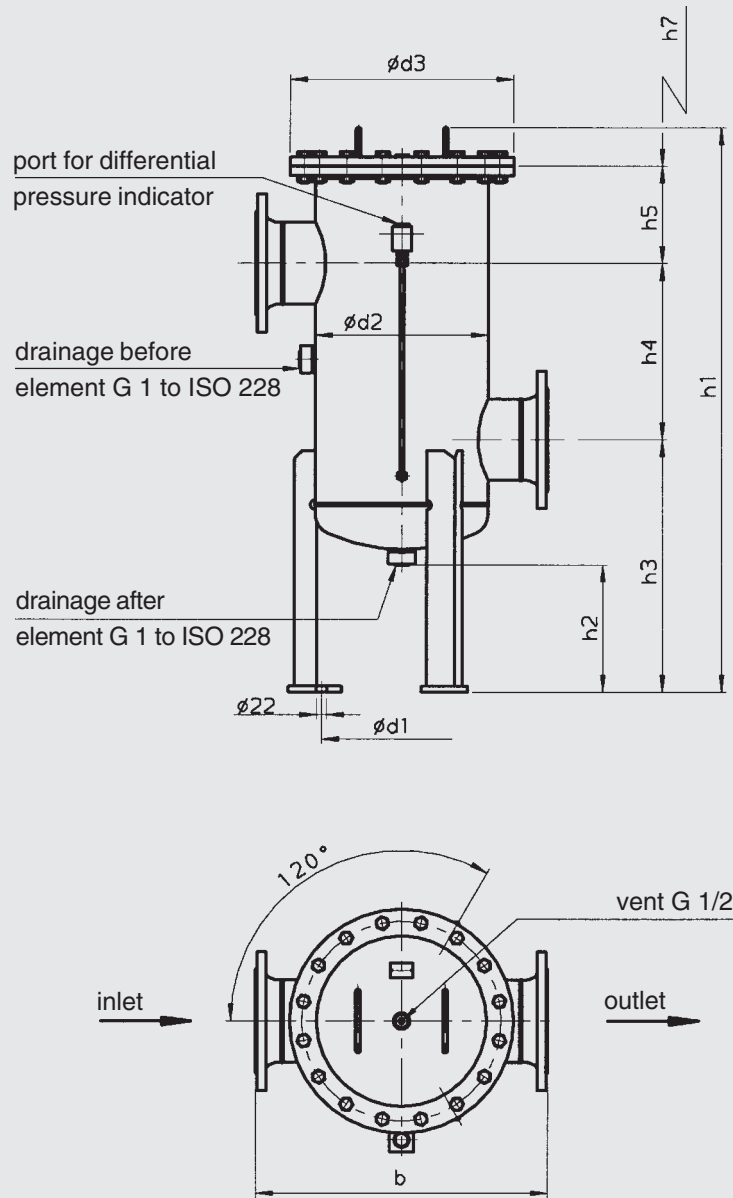

Type	Flange connection	b	d1	d2	d3	h1	h2	h3	h4	h5	h7
RFL 4000/4020	DIN DN 80	600	330	355.6	460	1079/1469	266	475	410	115/505	420/810
	DIN DN 100	600	330	355.6	460	1079/1469	266	475	304	221/661	420/810
	DIN DN 125	600	330	355.6	460	1169/1459	266	525	380	185/575	420/810
	DIN DN 150	600	330	355.6	460	1169/1559	266	525	365	200/590	420/810
	DIN DN 200	600	330	355.6	460	1204/1594	266	525	365	235/625	420/810
RFL 5200/5220	DIN DN 80	600	380	406.4	510	1144/1584	244	465	410	191/631	500/940
	DIN DN 100	600	380	406.4	510	1144/1584	244	465	304	297/737	500/940
	DIN DN 125	600	380	406.4	510	1256/1696	244	525	380	271/711	500/940
	DIN DN 150	600	380	406.4	510	1256/1696	244	525	365	286/726	500/940
	DIN DN 200	640	380	406.4	510	1256/1696	244	525	365	286/726	500/940
	DIN DN 250	660	380	406.4	510	1324/1764	244	560	450	236/676	500/940
RFL 6500/6520	DIN DN 100	740	480	508	620	1260/1700	255	540	304	336/776	500/940
	DIN DN 125	740	480	508	620	1260/1700	255	540	380	260/700	500/940
	DIN DN 150	740	480	508	620	1260/1700	255	540	365	275/715	500/940
	DIN DN 200	740	480	508	620	1380/1820	255	600	460	240/680	500/940
	DIN DN 250	780	480	508	620	1380/1820	255	600	450	250/690	500/940
RFL 7800/7820	DIN DN 100	740	480	508	620	1260/1700	255	540	304	336/776	500/940
	DIN DN 125	740	480	508	620	1260/1700	255	540	380	260/700	500/940
	DIN DN 150	740	480	508	620	1260/1700	255	540	365	275/715	500/940
	DIN DN 200	740	480	508	620	1380/1820	255	600	460	240/680	500/940
	DIN DN 250	780	480	508	620	1380/1820	255	600	450	250/690	500/940
RFL 15000/ 15020	DIN DN 200	1000	690	711	830	1425/1865	263	655	365	330/770	500/940
	DIN DN 250	1000	690	711	830	1425/1865	263	655	450	245/685	500/940
	DIN DN 300	1000	690	711	830	1495/1935	263	670	515	235/675	500/940

7. NOTE

The information in this brochure relates to the operating conditions and applications described.  
For applications or operating conditions not described, please contact the relevant technical department.  
Subject to technical modifications.