

HYDAC

INTERNATIONAL

ISO 9001
QUALITY
WITH SYSTEM

Return Line & Suction Boost Filter RKM

Flow rates up to 800 l/min
Pressure ranges up to 10 bar
Material: Aluminium / Steel /
Synthetic material

The RKM return line & suction boost filter for the mobile industry is designed for use in units with combined hydraulic circuits. The suction boost filter for the hydrostatic drive and the return line filter for the operating hydraulics are replaced by this one filter.

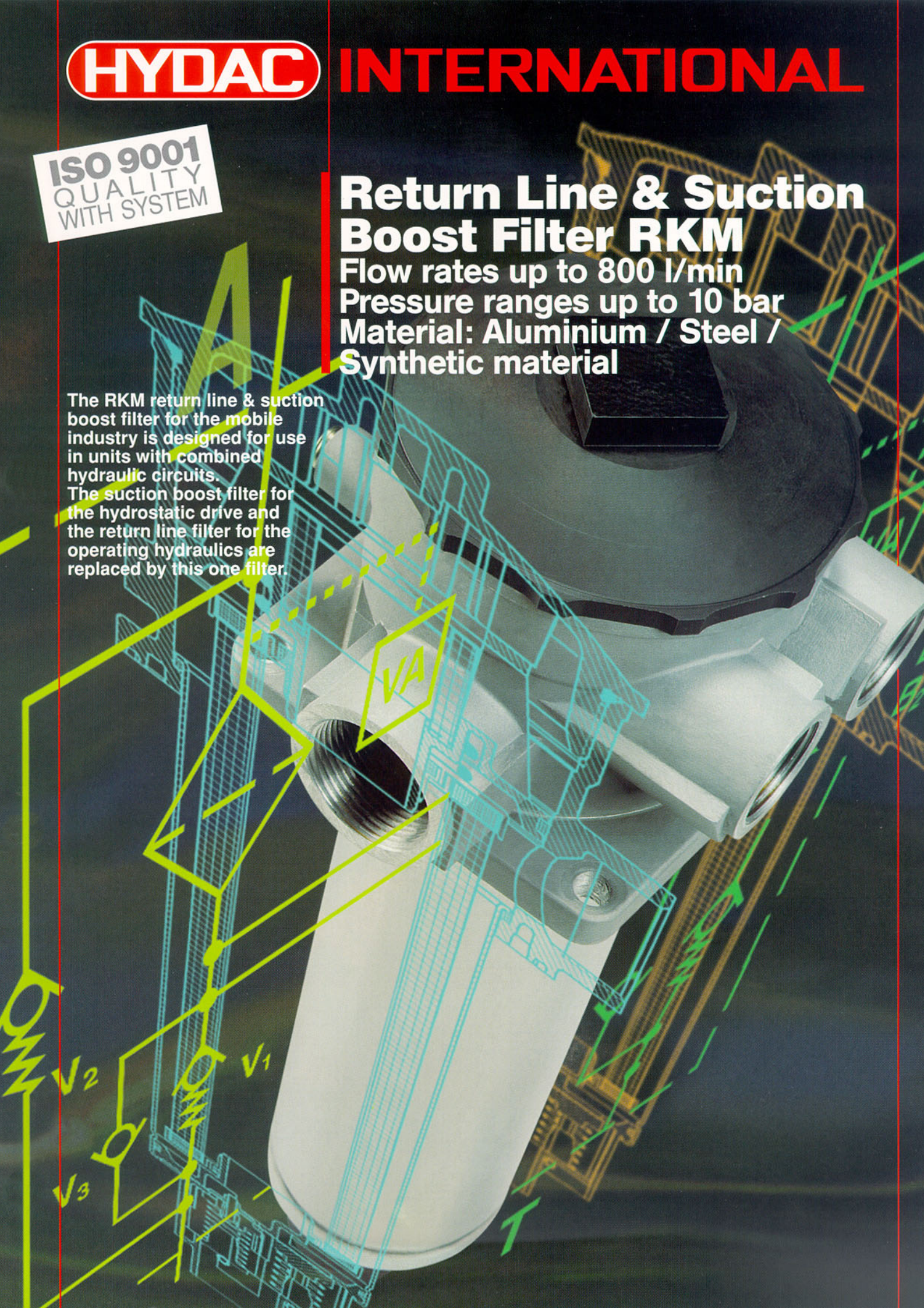

Application

RKM return line & suction boost filters for the mobile industry are used in units with both open-loop hydraulic circuits (e.g. operating hydraulics) and closed-loop hydrostatic drives (e.g. transmissions).

RKM filters therefore combine the function of the return line filter of the open-loop circuit and the suction boost filter of the closed-loop drive in one filter. The return flow must always be greater than the flow rate of the hydrostatic feed pump on these applications.

Function

The return line flow of the operating hydraulics is fed to the filter via port A and is cleaned by the filter element (full flow return line filtration). A pressure (standard = 0.5 bar) is applied by the back-pressure valve V1. This ensures that the filtered return line flow is available to the hydrostatic feed pump via port B (full flow suction boost filtration). Excess quantities are drained via the back-pressure valve to the tank (port T).

A bypass valve V2 (standard = 2.5 bar) is fitted to relieve excessive back-pressures in the element (important on cold starts). Flow from the tank can be fed via the anti-cavitation valve to the suction side for a short time (emergency function).

Advantages

- Full flow finest filtration (10 μm , 15 μm absolute) of return line and hydrostatic feed pump which extends the service life of your components.
- Outstanding cold start characteristics due to precharge via back pressure valve (standard = 0.5 bar).
- Due to the advanced RK element technology and specially developed bypass valves, the lowest back-pressures can be achieved across the filter even at very low temperatures.

Function diagram:

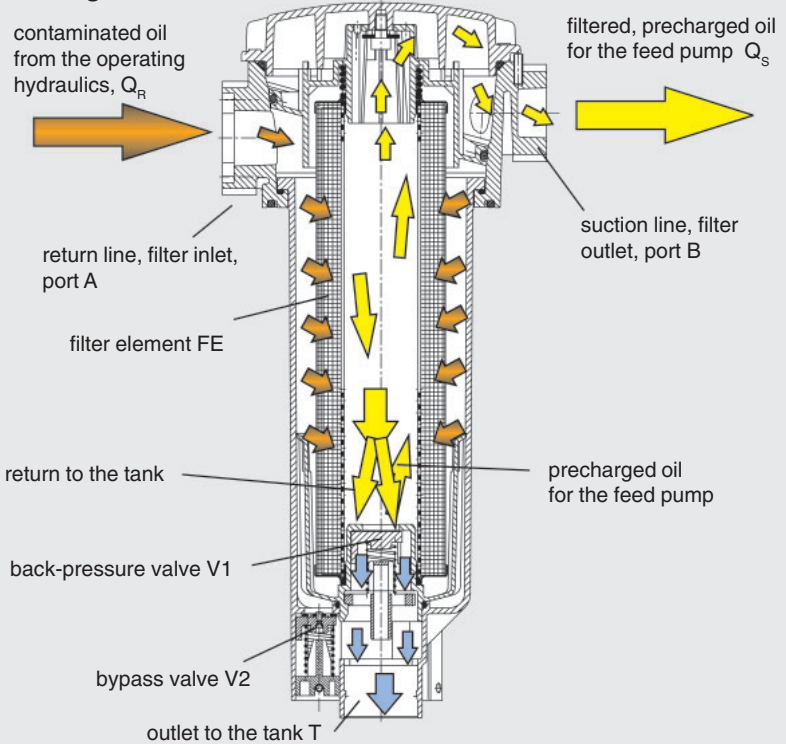

Anti-cavitation:

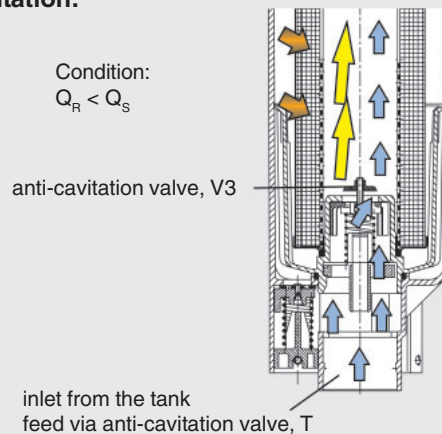

Circuit example:

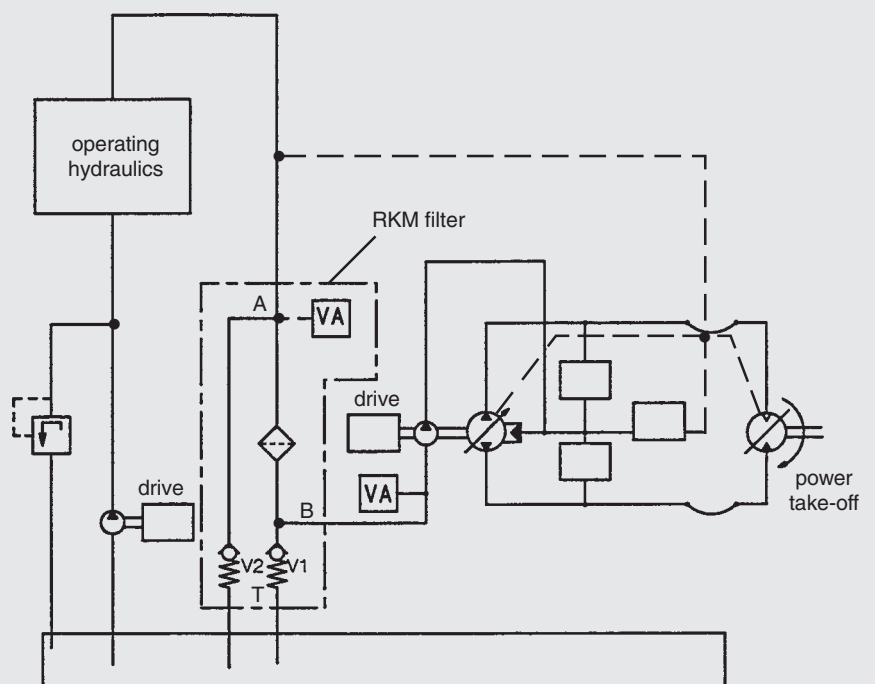

1. TECHNICAL DESCRIPTION

1.1. FILTER HOUSING

Construction

The RKM filter essentially consists of a filter head, a filter bowl, a cover plate and a filter element. It also has a bypass valve, a back-pressure valve and optionally an anti-cavitation valve.

1.2. FILTER ELEMENTS

Hydac filter elements are tested according to the following ISO standards:

- ISO 3724 Verification of flow fatigue characteristics
- ISO 4572 Contamination retention capacity
- ISO 4572 Multi-pass method for evaluating filtration performance
- ISO 3968 Evaluation of pressure drop versus flow characteristics
- ISO 2942 Bubble point test
- ISO 2941 Verification of collapse / burst resistance

Reliable filter operation is only guaranteed for Hydac original filter elements.

The filter elements are also suitable for dynamic conditions due to their high pressure stability: max permissible Δp across the element:

Betamicon® (BN3HC): 10 bar

The flow through the elements is from out to in. With regard to filtration rating, pressure drop and contamination retention, excellent values are achieved.

Fluid compatibility

Suitable for mineral oils, lubrication oils, non-flam fluids, synthetic and rapidly biodegradable fluids.

1.3. CLOGGING INDICATORS

VMF 2 F . 0

Type of indicator

VMF return line indicator or vacuum indicator

Pressure setting

-0.2 0.2 bar (vacuum)
2 2.0 bar (back-pressure)

Indicator type code

E. = pressure gauge
F. = pressure switch
K. = return line vacuum pressure gauge
UF. = vacuum pressure switch

Modification number

0 latest version is always supplied

The return line indicator monitors the contaminated element.
The vacuum indicator monitors the suction boost side of the feed pump.
For further details, please see Clogging Indicators brochure,
no. E 7.050../..

1.4. SEALS

Perbunan (= NBR) or Viton
(= FPM for HFD oils)

1.5. SPECIAL MODELS AND ACCESSORIES

- Extension in the filter outlet
- Breather valve
- Size 400, 800 port size suction boost line SAE DN 50

1.6. SPARE PARTS

Please see Spare Parts List and Maintenance Instructions – brochure no.: E 7.108.E../..

2. GENERAL

Mounting

Tank top mounted filter

Temperature range

-30 °C to +100 °C
(short-term -40 °C)

Pressure setting of the return line clogging indicator

$\Delta p_a = 2 \text{ bar } -10\%$

Other pressure settings on request

Cracking pressure of the bypass valve

$\Delta p_o = 2.5 \text{ bar } +0.3 \text{ bar}$

Setting back pressure valve

$\Delta p_v = 0.5 \text{ bar}$

Other cracking or back pressure pressures on request

3. MODEL CODE

(also order example)

3.1. COMPLETE FILTER

RKM BN/HC 300 B T F 10 W 0 . X /-B6-CV3

Filter type _____

Filter material of element _____

BN/HC Betamicron® (BN3HC)

Size / Housing material _____

Al/St/PA: 100, 201, 251, 400, 800

Al/PA: 300

Operating pressure _____

B = 10 bar

Type of port / Size of suction line port _____

Type	Port	Filter size					
		100	201	251	300	400	800
P	1x G 1"/1x G 1 1/4"					•	•
Q	4x G 1 1/2"					•	•
R	4x G 1 1/4"					•	•
T	2x CS 1 1/4"				•		
U	2x G 1 1/4"					•	•
V	2x G 1"		•	•		•	•
W	1x G 1 1/4"					•	•
X	1x G 1"	•					
Y	1x G 3/4"	•					
Z	According to customer specification						

Type of port / Size of return line port _____

Type	Port	Filter size					
		100	201	251	300	400	800
C	G 3/4"	•					
D	G 1"	•					
E	G 1 1/4"		•	•			
F	CS 1 1/2"				•		
L	SAE DN 50 (2")					•	•
M	SAE DN 65 (2 1/2")					•	•
Z	According to customer specification						

Other port sizes on request.

Filtration rating in µm _____

BN3HC: 10, 15

Type of clogging indicator _____

W no port for clogging indicator

Y port for clogging indicator

A with blanking plug

E with pressure gauge

F with pressure switch

K return line and vacuum pressure gauge

UF vacuum switch

for other clogging indicators see brochure no. E 7.050../..

Type code _____

0 no indicator

1-8 see point 3.1.1

Modification number _____

X the latest version is always supplied

Supplementary details _____

no details = standard (without anti-cavitation valve; seals in NBR, bypass valve 2.5 bar, back-pressure valve 0.5 bar)

V FPM (Viton) seals, filter suitable for rapidly biodegradable hydraulic fluids

B2 bypass valve with 2 bar cracking pressure

B6-CV3 bypass valve with 6 bar cracking pressure and back-pressure valve with 3 bar cracking pressure

NR with anti-cavitation valve

NRF125 with anti-cavitation valve and coarse filter strainer 125 µm

ND with pressure release valve

NB with anti-cavitation valve via the main bypass valve

GRxx with threaded adaptor for the return line port, only for size 300

GSxx with threaded adaptor for the suction boost port, only for size 300

EV air bleed valve

UT suitable for use when immersed in oil

3.1.1 Type code

Size 100

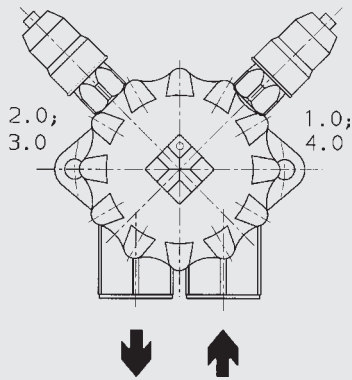

Type Code	Mounting position of the clogging indicator	Type of clogging indicator	Measuring
1.0	on the filter inlet – right-hand side, bottom	return line	before the filter element
2.0	on the filter inlet – left-hand side, bottom	return line	before the filter element
3.0	on the filter outlet – right-hand side, top	vacuum	after the filter element
4.0	on the filter outlet – left-hand side, top	vacuum	after the filter element
5.0	type code 1.0 and 3.0	2 indicators: return line & vacuum	before & after the filter element
6.0	type code 2.0 and 4.0	2 indicators: return line & vacuum	before & after the filter element

Size 201

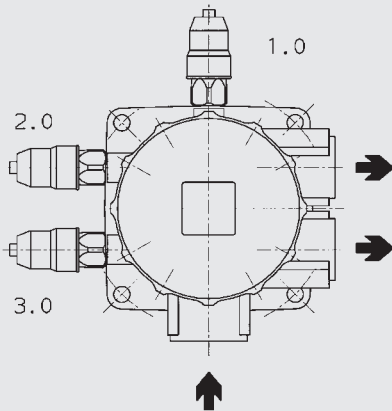

Type Code	Mounting position of the clogging indicator	Type of clogging indicator	Measuring
1.0	on the filter inlet – opposite side	return line	before the filter element
2.0	on the filter inlet – left-hand side	return line	before the filter element
3.0	on the filter outlet – right-hand side	vacuum	after the filter element
5.0	type code 1.0 and 3.0	2 indicators: return line & vacuum	before & after the filter element
6.0	type code 2.0 and 3.0	2 indicators: return line & vacuum	before & after the filter element
7.0	type code 1.0 and 2.0	2 indicators: return line	before the filter element

Size 251

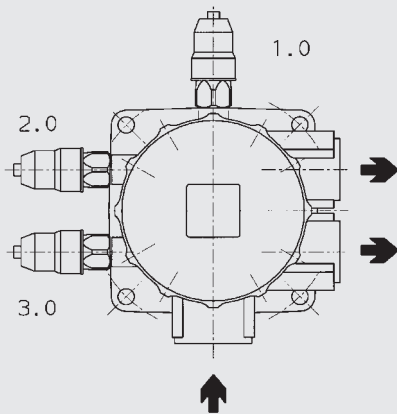

Type Code	Mounting position of the clogging indicator	Type of clogging indicator	Measuring
1.0	on the filter inlet – opposite side	return line	before the filter element
2.0	on the filter inlet – left-hand side	return line	before the filter element
3.0	on the filter outlet – right-hand side	vacuum	after the filter element
5.0	type code 1.0 and 3.0	2 indicators: return line & vacuum	before & after the filter element
6.0	type code 2.0 and 3.0	2 indicators: return line & vacuum	before & after the filter element
7.0	type code 1.0 and 2.0	2 indicators: return line	before the filter element

Size 300

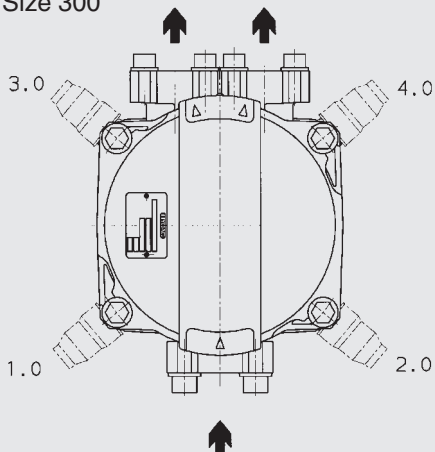

Type Code	Mounting position of the clogging indicator	Type of clogging indicator	Measuring
1.0	on the filter inlet – left-hand side	return line	before the filter element
2.0	on the filter inlet – right-hand side	return line	before the filter element
3.0	on the filter outlet – left-hand side	vacuum	after the filter element
4.0	on the filter outlet – right-hand side	vacuum	after the filter element
5.0	type code 1.0 and 3.0	2 indicators: return line & vacuum	before & after the filter element
6.0	type code 2.0 and 4.0	2 indicators: return line & vacuum	before & after the filter element
7.0	type code 1.0 and 2.0	2 indicators: return line	before the filter element
8.0	type code 3.0 and 4.0	2 indicators: vacuum	after the filter element

Size 400

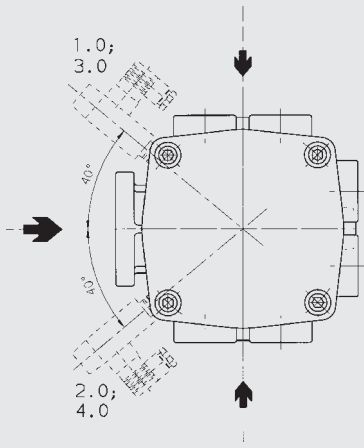

Size 800

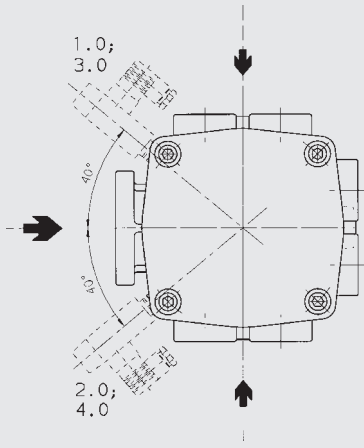

Type Code	Mounting position of the clogging indicator	Type of clogging indicator	Measuring
1.0	on the filter inlet – left-hand side, bottom	return line	before the filter element
2.0	on the filter inlet – right-hand side, bottom	return line	before the filter element
3.0	on the filter inlet – left-hand side, top	vacuum	after the filter element
4.0	on the filter inlet – right-hand side, top	vacuum	after the filter element
5.0	type code 1.0 and 3.0	2 indicators: return line & vacuum	before & after the filter element
6.0	type code 2.0 and 4.0	2 indicators: return line & vacuum	before & after the filter element
7.0	type code 1.0 and 2.0	2 indicators: return line	before the filter element
8.0	type code 3.0 and 4.0	2 indicators: vacuum	after the filter element

Type Code	Mounting position of the clogging indicator	Type of clogging indicator	Measuring
1.0	on the filter inlet – left-hand side, bottom	return line	before the filter element
2.0	on the filter inlet – right-hand side, bottom	return line	before the filter element
3.0	on the filter inlet – left-hand side, top	vacuum	after the filter element
4.0	on the filter inlet – right-hand side, top	vacuum	after the filter element
5.0	type code 1.0 and 3.0	2 indicators: return line & vacuum	before & after the filter element
6.0	type code 2.0 and 4.0	2 indicators: return line & vacuum	before & after the filter element
7.0	type code 1.0 and 2.0	2 indicators: return line	before the filter element
8.0	type code 3.0 and 4.0	2 indicators: vacuum	after the filter element

3.1.2 Symbols

Standard

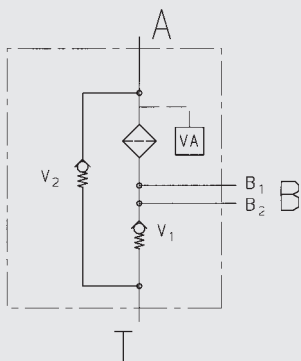

/-NRF125 (with anti-cavitation valve and a coarse filter with 125 µm)

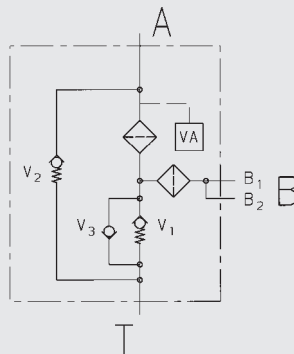

/-ND (with pressure release valve)

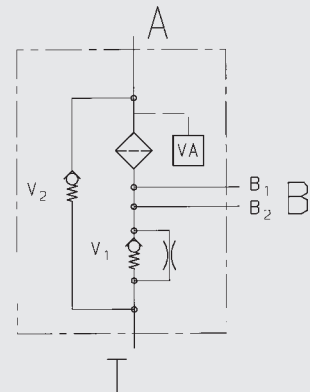

/-NR (with anti-cavitation)

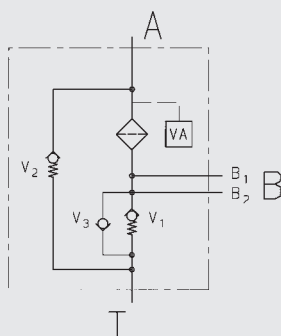

/-NB (with anti-cavitation via the main bypass valve)

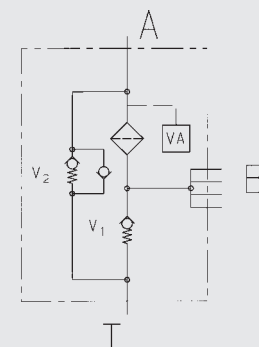

3.2. REPLACEMENT ELEMENT (also order example)

	0300 RK 010 BN3HC /-V
Size _____	_____
0100, 0201, 0251, 0300, 0400, 0800	
Type _____	_____
RK	
Filtration rating in μm _____	_____
BN3HC: 10, 15	
Filter material _____	_____
BN3HC	
Supplementary details _____	_____
V = FPM seals, filter suitable for rapidly biodegradable oils	

4. FILTER SPECIFICATIONS

Filter type/ Nominal flow rate (l/min)	Suction boost port*	Return line port*	Element size	Contam- ination retention 10 μm (g)	Contam- ination retention 15 μm (g)	β values	Weight (kg) with element
100	G 3/4 G 1	G 3/4 G 1	0100 RK...	16.3	19.6	$\beta_{10,15} > 100$	1.7
201	G 1	G 1 1/4	0201 RK...	50.9	61.4	$\beta_{10,15} > 100$	3.7
251	G 1	G 1 1/4	0251 RK...	61.9	74.7	$\beta_{10,15} > 100$	4.0
300	CS 1 1/4	CS 1 1/2	0300 RK...	55.6	67.1	$\beta_{10,15} > 100$	4.6
400	G 1 G 1 1/4 G 1 1/2	G 1 G 1 1/4 G 1 1/2 SAE DN 50 SAE DN 65	0400 RK...	67.4	81.3	$\beta_{10,15} > 100$	6.5
800	G 1 G 1 1/4 G 1 1/2	G 1 G 1 1/4 G 1 1/2 SAE DN 50 SAE DN 65	0800 RK...	86.3	104.2	$\beta_{10,15} > 100$	7.5

* = for number, size of ports etc.:
see point 3.1.

Model code for complete filter:
Type of port / Port size

5. FILTER CALCULATION / SIZING

5.1. RECOMMENDED FILTRATION RATING

The elements are available in the filtration ratings 10 and 15 μm absolute ($\beta_x > 100$). In our experience the required cleanliness classes are always reached without problem even with the 15 μm material. Due to the outstanding cold start characteristics (low Δp at high oil viscosity) we recommend that the 15 μm material should be used for normal operating conditions.

5.2. RECOMMENDATION – INITIAL PRESSURE DROP

We recommend a maximum permissible initial pressure drop with clean element of 1 bar at the given flow rate and at a viscosity of 30 mm^2/s (= 0.5 bar across the element and housing + 0.5 bar back pressure).

5.3. ΔP -Q-DIAGRAMS FOR COMPLETE FILTER (INCL. ELEMENT)

The flow rate / pressure drop curves for the RKM filter are shown in the following graphs.

These curves apply to mineral oil with a density of 0.86 kg/dm^3 and a viscosity of 30 mm^2/s .

FLOW RATE / PRESSURE DROP GRAPHS
(HOUSING WITH ELEMENT)

Size 100

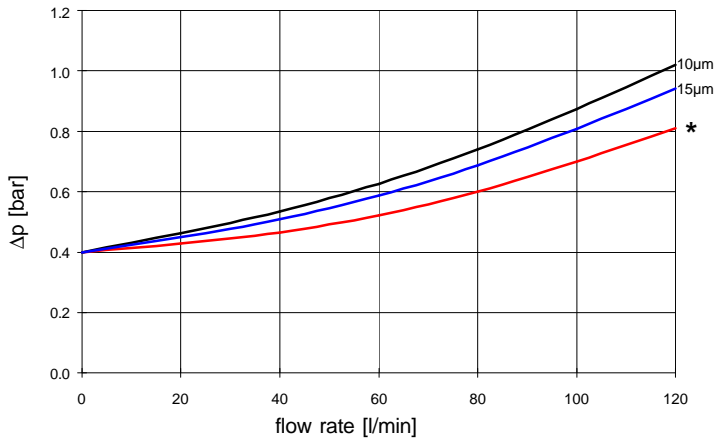

Size 300

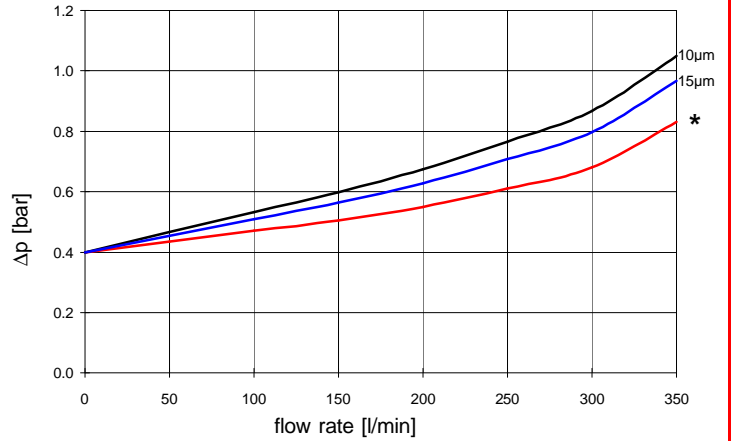

Size 201

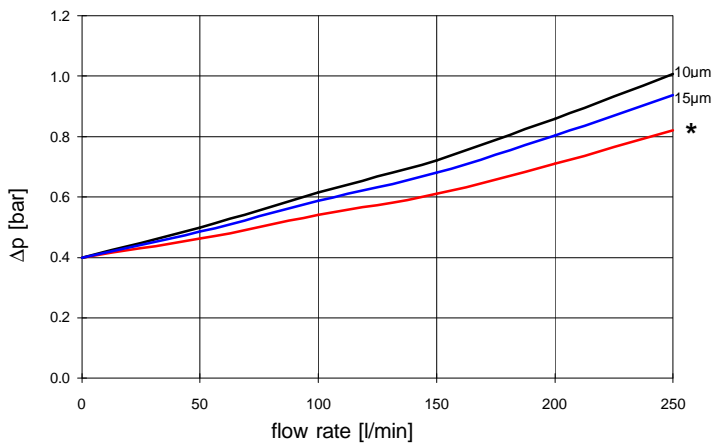

Size 400

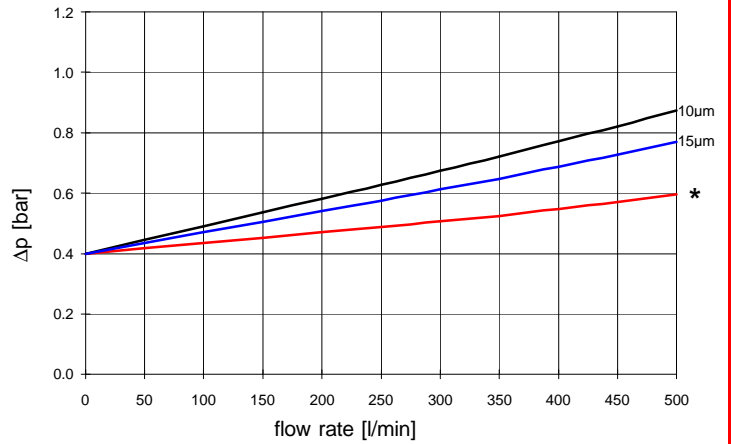

Size 251

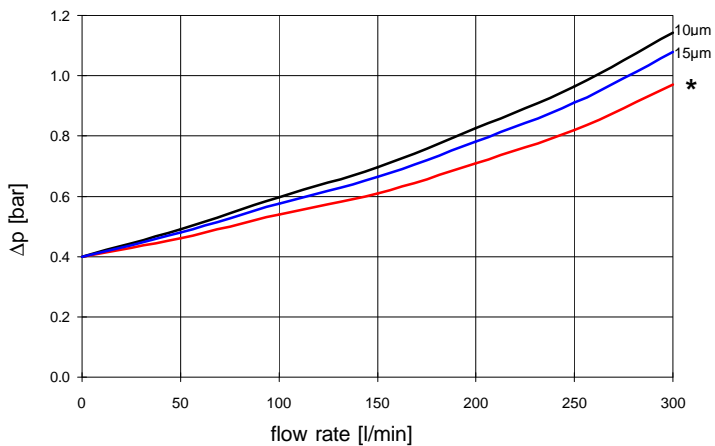

Size 800

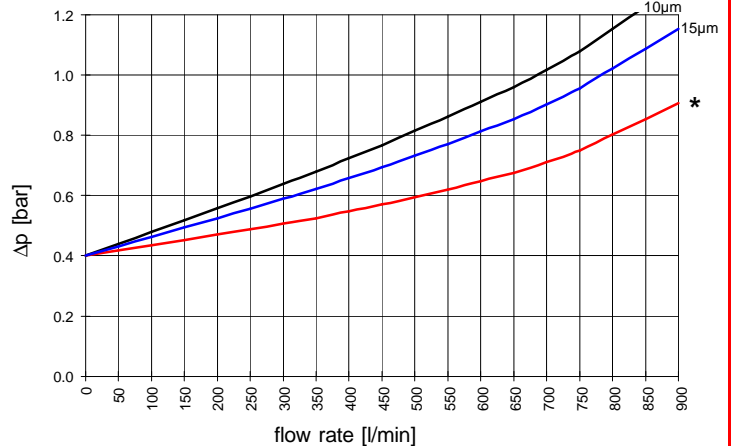

* = housing only

* = housing only

5.4. EXAMPLE

System parameters:

Return line flow: $Q = 80$ l/min;

BN3HC element

Filtration rating: $15 \mu\text{m}$ absolute

$\Delta p =$ found in the graphs under point 5.3.

\Rightarrow RKM 100

6. DIMENSIONS

6.1. RKM 100

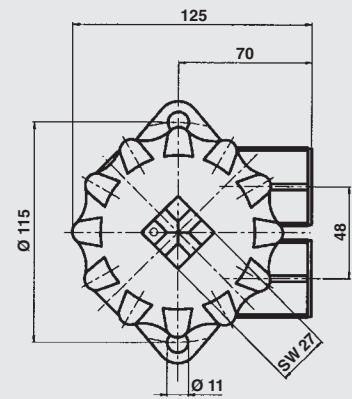
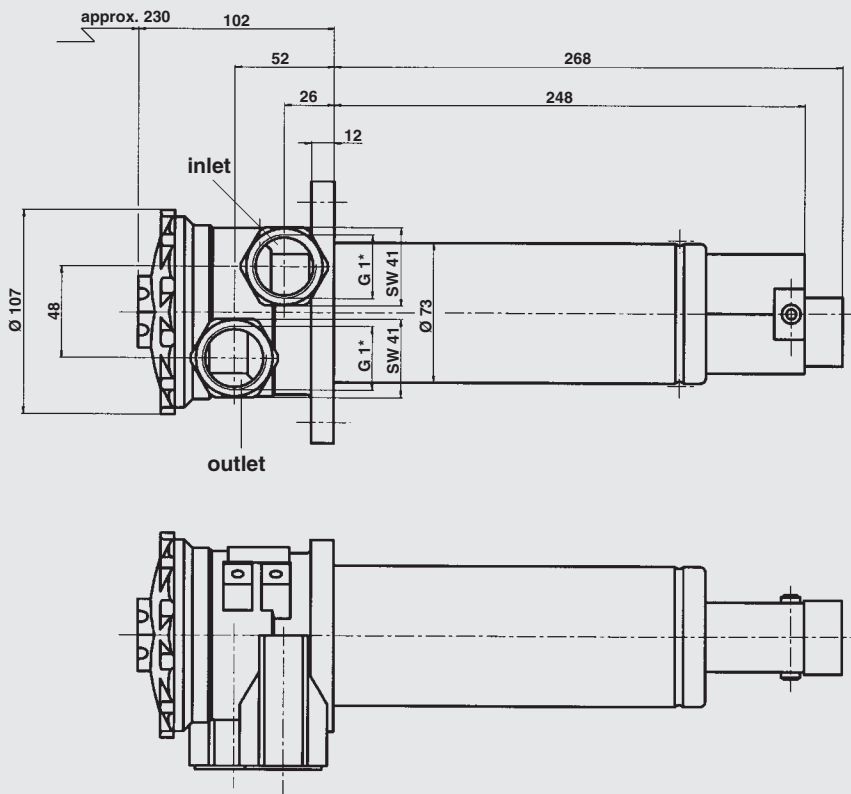

Port sizes

Inlet	G 3/4	G 1
Outlet	G 3/4	G 1

6.2. RKM 201, 251

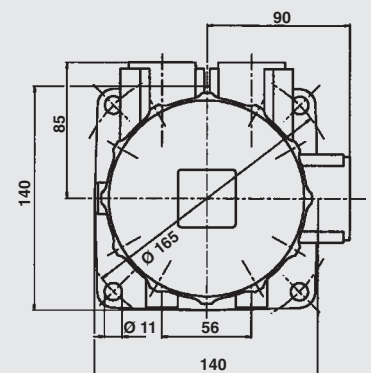
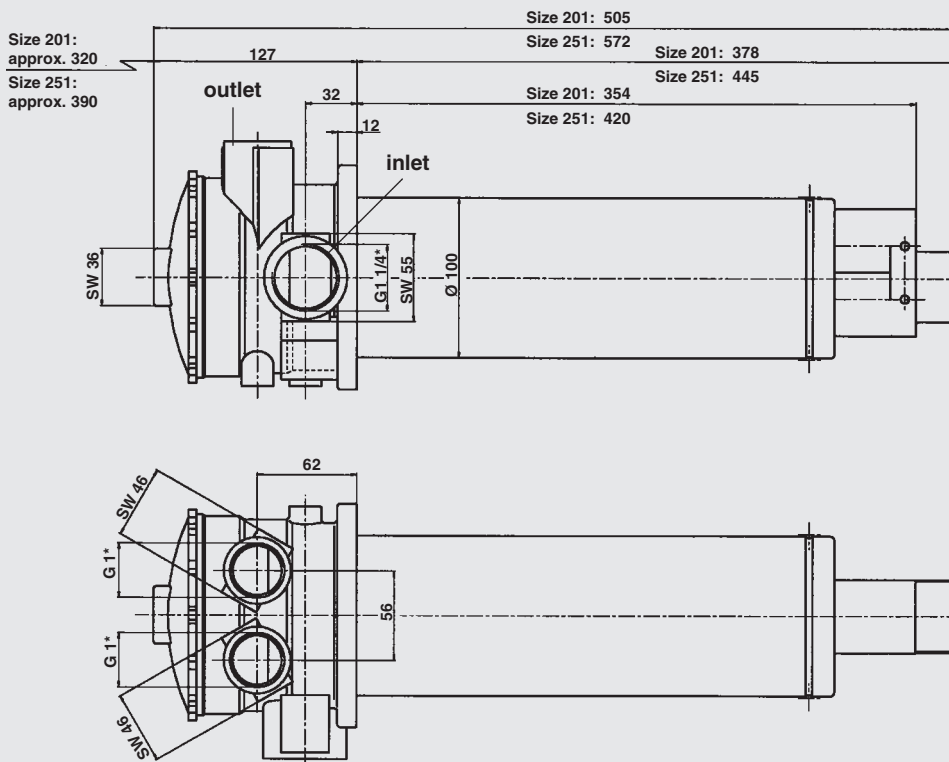

* = for number, size of ports etc.: please see point 3.1.
Model code for complete filter: Type of port / Port size

6.3. RKM 300

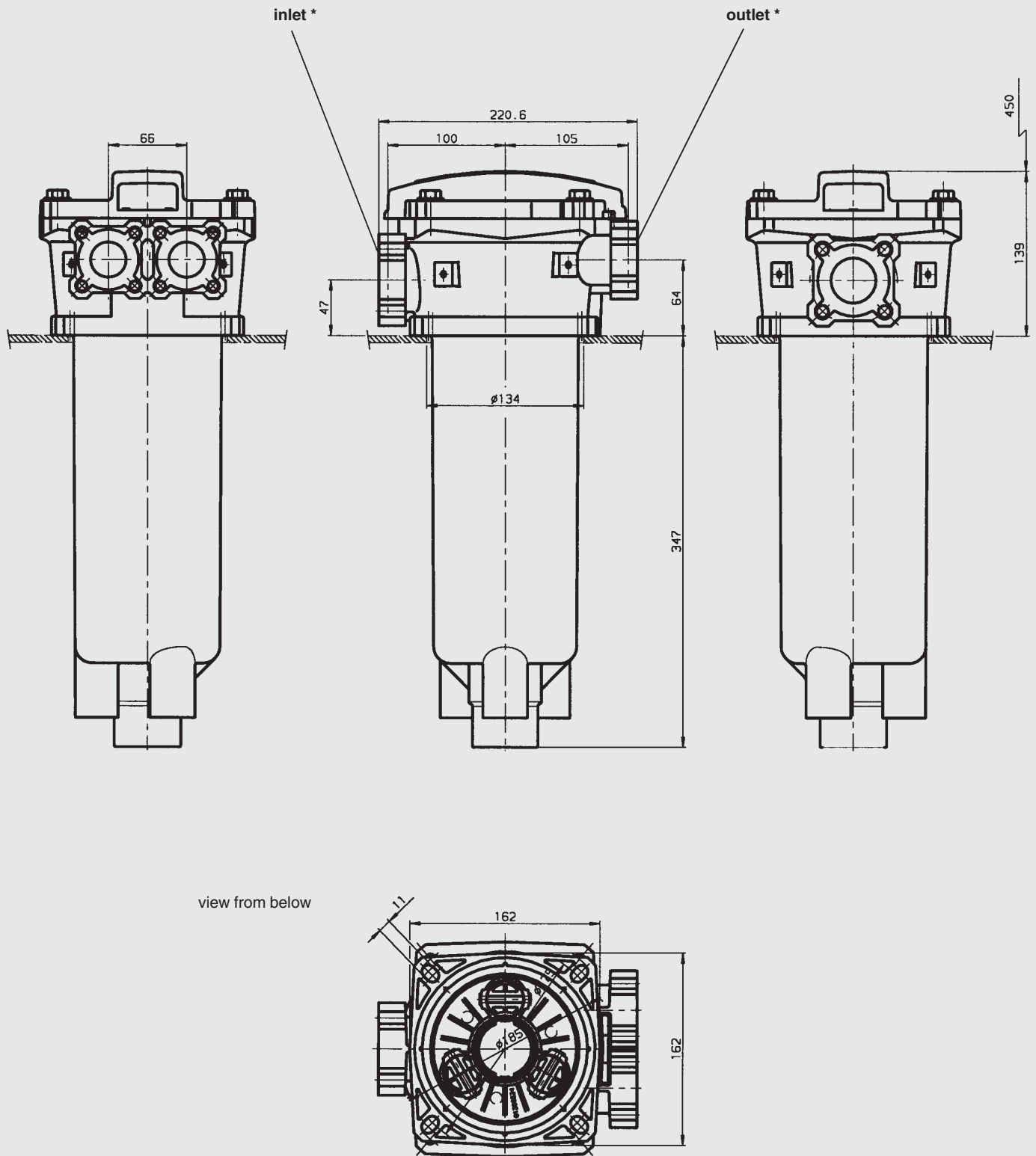

* = for number, size of ports etc.: please see point 3.1.
 Model code for complete filter: Type of port / Port size

6.4. RKM 400, 800

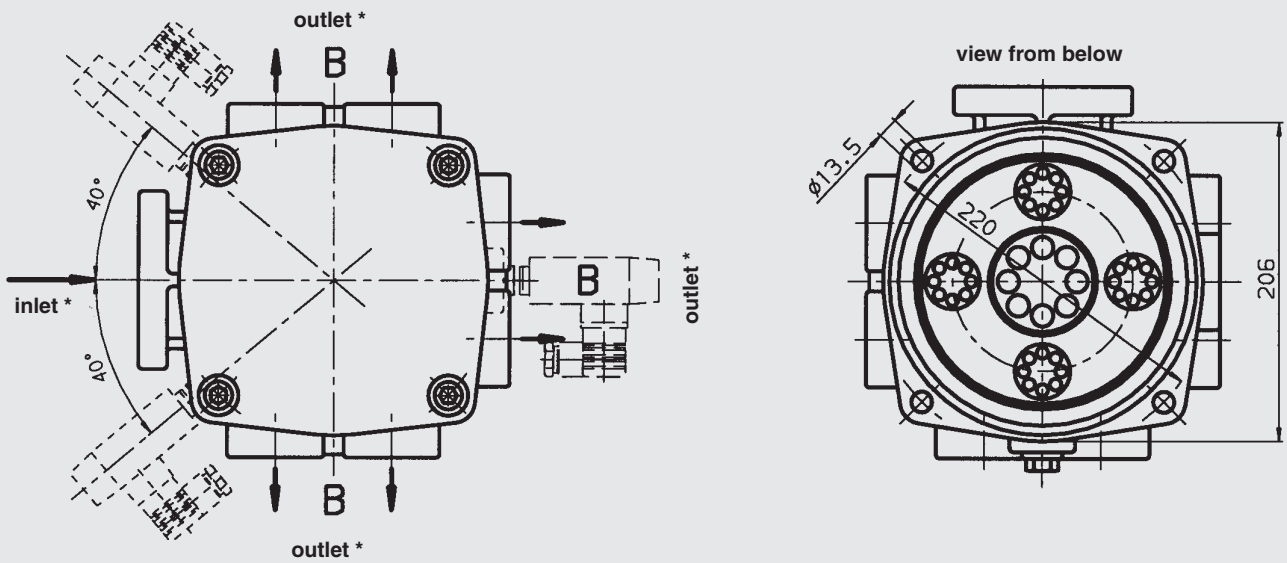
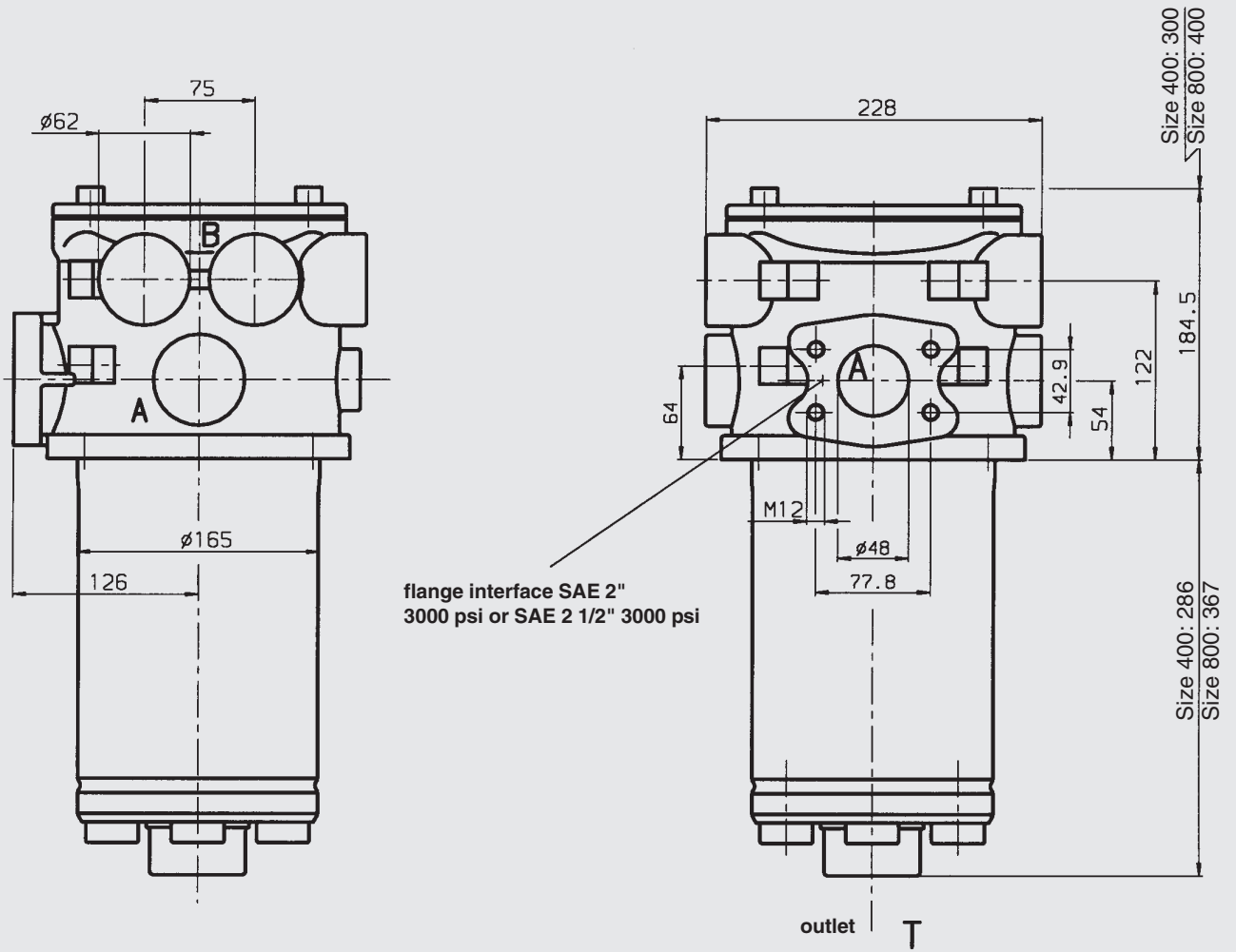

* = for number, size of ports etc.: please see point 3.1.
 Model code for complete filter: Type of port / Port size

7. NOTE

The information in this brochure relates to the operating conditions and applications described. For applications or operating conditions not described, please contact the relevant technical department. Subject to technical modifications.