

HYDAC

INTERNATIONAL

Change-Over

Inline Filter RFLD

Cast Version

Flow Rates up to 1300 l/min*

Pressure Range 25/40/64 bar

With Ball Change-Over Valve



* For higher flow rates,
please refer to brochure
RFLD Welded Version

1. TECHNICAL SPECIFICATIONS

1.1. FILTER HOUSING

Construction

The filter housings and connecting elements have been designed in accordance with international regulations.

The two filter housings are connected by means of a ball change-over valve with negative overlap and single lever operation.

All filters size DN 80 and over are fitted with a pressure compensation line and ball shut-off valve. This enables filling to be carried out and the pressure between the two filter sides to be equalised.

Connections for venting, draining and for the clogging indicator are part of the standard model.

WARNING

When using W/HC and P/HC elements please follow the sizing recommendation given on page 5. An electrostatic charge can build up across the element on all inline filters. Ensure that the filters are earthed before use to allow equalisation of potential.

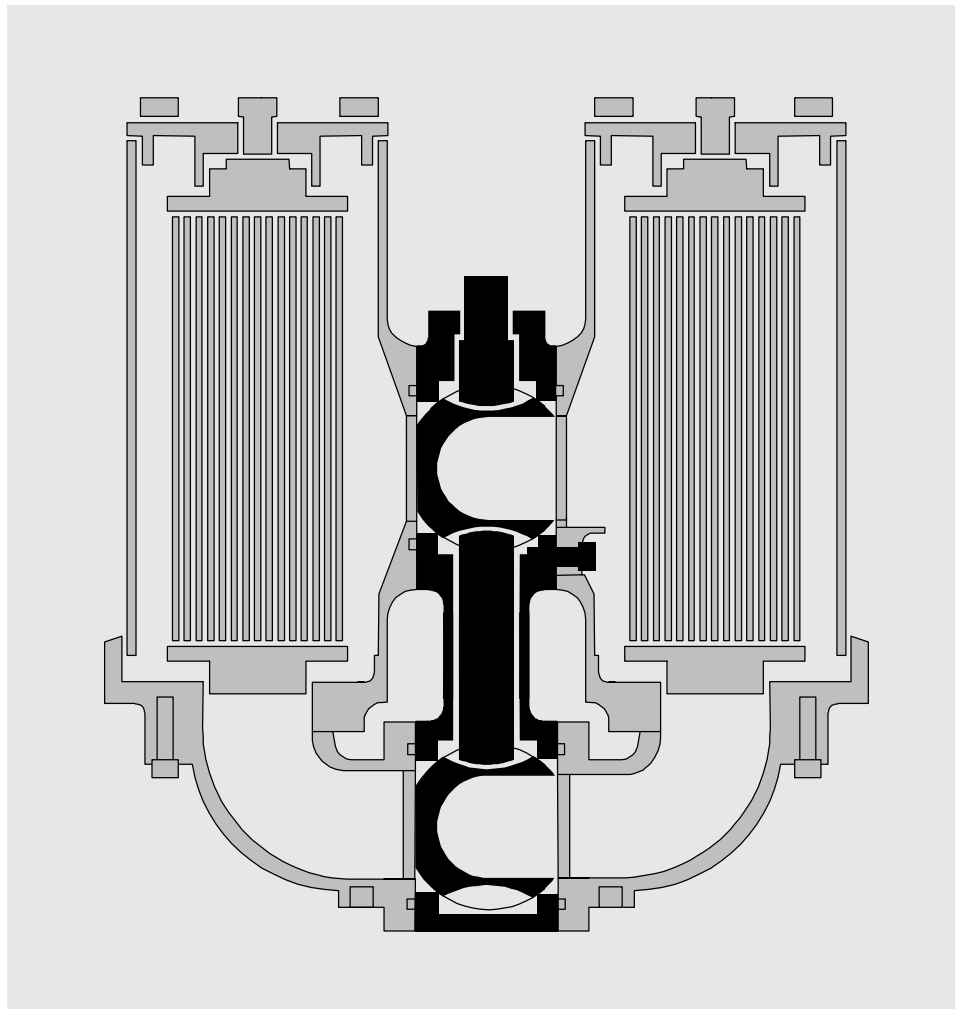

1.2. FILTER ELEMENTS

Original Hydac filter elements guarantee reliable function and protect hydraulic components and systems which are sensitive to contamination from wear and tear. Performance and quality tests according to international standards guarantee reliable operation of the filter.

HYDAC filters are validated and their quality is continuously monitored according to the following standards:

- DIN ISO 2941:
Verification of collapse / burst resistance
- DIN ISO 2942:
Verification of fabrication integrity and determination of first bubble point
- DIN ISO 2943:
Verification of material compatibility with fluids
- ISO 3724:
Verification of flow fatigue characteristics
- ISO 3968:
Evaluation of pressure drop versus flow characteristics
- ISO 16889:
Multi-pass method for evaluating filtration performance of a filter element

In addition to guaranteeing retention and flow rate characteristics, the filter elements have excellent structural stability.

The careful construction and mechanically stable support of the filter media guarantee above-average beta value stability and flow fatigue characteristics of the filter elements.

The filter elements are available with the following collapse/burst stability values:

Betamicon®(BN3HC)	: 25 bar
Paper (P/HC)	: 10 bar
Wire mesh (W/HC)	: 30 bar
Stainless steel fibre (V)	: 30 bar
Betamicon®/Aquamicron® (BN/AM)	: 10 bar
Aquamicron® (AM)	: 10 bar

1.3. CLOGGING INDICATORS

	VM 2 D . X /-L220
Type of indicator	VM differential pressure measurement up to 210 bar operating pressure
Pressure setting	2 2 bar standard, others on request
Indicator type code (options)	B. = visual C. = electrical D. = visual/electrical VE. = visual, analogue/electrical
Modification number	X the latest version is always supplied
Supplementary details	-V Viton -LED 2 light-emitting diodes up to 24 Volt -L.. light with corresponding voltage (24, 48, 110, 220 Volt) -W only for oil/water emulsions HFA, HFC (only possible for "VD" version)

Clogging indicators are fitted as standard between the inlet and outlet of the filter.
Option: Δp measurement across the element.
For further details on clogging indicators, please see:
brochure no.: E 7.050../.

1.4. SEALS

Choice of Perbunan (= NBR) or Viton (= FPM for HFD fluids)

1.5. SPECIAL MODELS AND ACCESSORIES

- Orifice in the pressure compensation line
- Stand
- Draining and venting connections with ball valves or other shut-off valves
- Mating flanges available for all sizes
- Change-over valve lockable
- Other sealing materials
- Venting line with sight glasses \Rightarrow visual control

1.6. SPARE PARTS

See Original Spare Parts List and Maintenance Instructions.

1.7. CERTIFICATION AND APPROVAL

The filters can be supplied with manufacturer's certificates O and M to DIN 55350, Part 18.

Test certificates 3.1.B to EN 10204 and material certificates from the approval authorities Germanischer Lloyd (GL), Lloyd's Register (LR), American Bureau of Shipping (ABS), Bureau Veritas (BV) and Det Norske Veritas (DNV) can be supplied.

1.8. COMPATIBILITY WITH OPERATING FLUIDS DIN ISO 2943

- Hydraulic oils H to HLPD to DIN 51524
 - Lubrication oils to DIN 51517, APJ, ACEA, DIN 51515, ISO 6743
 - Compressor oils to DIN 51506
 - Rapidly biodegradable operating fluids to VDMA 24568 HETG, HEES, HEPG
 - Non-flam operating fluids HFC and HFD
 - Operating fluids with high water content (>50 water content) on request
- For further details on filter elements:
Brochure no.: E 7.200../.

2. GENERAL

Mounting

Filters must be flexibly mounted and not fixed rigidly to the floor or used as a pipe support.

Direction of flow

Inlet: above
Outlet: below

Temperature range

-10 °C to +100 °C

Pressure setting of differential pressure clogging indicator

$\Delta p_a = 2 \text{ bar} -0.2 \text{ bar}$

Other pressure settings on request!

Cracking pressure of bypass valve

$\Delta p_o = 3 \text{ bar} +0.5 \text{ bar}$

Other cracking pressures on request!

Hydraulic systems

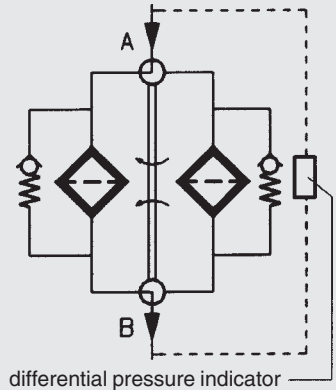

Lubrication systems

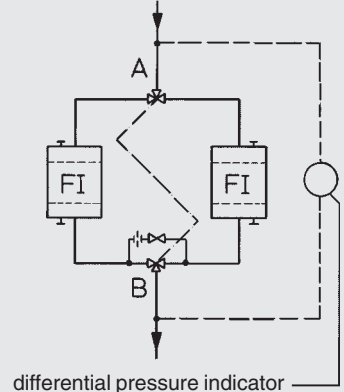

Change-over inline filters, type RFLD, are designed for inline mounting in hydraulic and lubrication systems which operate non-stop.

The filter materials can be selected according to the application.

3. MODEL CODE

(also order example)

3.1. COMPLETE FILTER

RFLD BN/HC 1301 D A S 10 D 1 . X /-L24

Filter type _____

Filter material of element _____

BN/HC Betamicron® (BN3HC)
 AM Aquamicon®
 BN/AM Betamicron®/Aquamicon®
 P/HC paper
 W/HC stainless steel wire mesh
 V stainless steel fibre

Size / Housing material _____

Cast iron GGG40: 111 / 241 / 331 / 501 / 661 / 851 / 951 / 1301 / 1321
 Cast steel GS: 332 / 502 / 662 / 852 / 952 / 1302 / 1322
 Cast stainless steel 1.4581: 503 / 853

Operating pressure _____

D = 25 bar (size 331 - 1301, 853)
 E = 40 bar (size 111 - 241, 503, 662 - 1302)
 F = 64 bar (size 332 - 502)

Type of change-over _____

A = ball all nominal widths

Type of connection / Connection sizes _____

Material of filter housing: GGG40 (●), GS + cast stainless steel (×), GS (*)

Type	Connection	Filter size							
		111	241	331 332	501 502 503	661 662	851 852 853	951 952	1301 1302
D	G1"	●							
F	G1 1/2		●						
I	SAE DN 25	●							
J	DIN DN 50			* ×*					
K	SAE DN 40		●	●	●				
L	SAE DN 50			●*	●*	●	●		
M	SAE DN 65					●	●		
Q	DIN DN 80					* *×			
R	DIN DN 100							*	*
S	SAE/DIN DN 80					●	●	●	●
T	SAE/DIN DN 100							●	●

Other nominal widths and ANSI flange version on request!

Filtration rating in µm _____

BN3HC, V : 3, 5, 10, 20
 BN/AM : 3, 10
 P/HC : 10, 20
 W/HC : 25, 50, 100, 200
 AM : 40

Type of clogging indicator _____

A without clogging indicator, steel blanking plug in indicator port
 B with visual indicator
 C with electrical indicator
 D with combined visual/electrical indicator

for other clogging indicators,
 see brochure no. E 7.050../..

Type code _____

1

Modification number _____

X the latest version is always supplied

Supplementary details _____

V FPM seals, filter suitable for rapidly biodegradable oils and phosphate ester (HFD-R)
 L... lamp with corresponding voltage (24V, 48V, 110V, 220V)
 LED 2 light-emitting diodes up to 24 volt
 KB without bypass valve
 B special cracking pressure of the bypass valve (B1 = 1 bar, B6 = 6 bar)
 STV stand
 SB pressure compensation line
 SB2 pressure compensation line with 2mm orifice
 DE differential pressure measurement across the element

3.2. REPLACEMENT ELEMENT

1300 R 010 BN3HC /-KB

Size _____
 0110, 0240, 0330, 0500, 0660, 0850, 0950, 1300
 (for element size, see point 4. Filter Specifications)

Type _____
 R

Filtration rating in μm _____
 BN3HC, V : 3, 5, 10, 20
 BN/AM : 3, 10
 P/HC : 10, 20
 W/HC : 25, 50, 100, 200
 AM : 40

Filter material _____
 BN3HC; V; BN/AM; P/HC; W/HC; AM

Supplementary details _____
 V = FPM seals, filter suitable for rapidly biodegradable oils and phosphate ester (HFD-R)
 W = filter suitable for oil-water emulsions (HFA, HFC), NBR seals
 KB = without bypass valve
 B. = special bypass cracking pressures (B1 = 1 bar, B6 = 6 bar)

4. FILTER SPECIFICATIONS

Filter type	Connection	Element size	Weight [kg] with element	Q_{max} when using W/HC and P/HC elements
111	G 1	0110 R...	17	70
	SAE DN 25		17	70
241	G1 1/2	0240 R...	27	170
	SAE DN 40		27	170
331	SAE DN 40	0330 R...	33	170
331/332	SAE DN 50		37	260
332	DIN DN 50		37	260
501	SAE DN 40	0500 R...	35	170
501/502	SAE DN 50		39	260
502/503	DIN DN 50		39	260
661	SAE DN 50	0660 R...	56	170
661	SAE DN 65		74	310
661	SAE/DIN DN 80		82	480
662	DIN DN 80		82	480
851	SAE DN 50	0850 R...	62	170
851	SAE DN 65		80	310
851/853	SAE/DIN DN 80		88	480
852	DIN DN 80		88	480
951	SAE/DIN DN 80	0950 R...	105	480
951	SAE/DIN DN 100		120	900
952	DIN DN 100		120	900
1301	SAE/DIN DN 80	1300 R...	110	480
1301	SAE/DIN DN 100		125	900
1302	DIN DN 100		125	900

No. of elements per side = 1

Housing material:

Material	Pressure range	Size/ Nom. flow rate l/min
Spherical cast iron GGG 40	p = 40 bar	111 - 241
	p = 25 bar	331 - 1301
Cast steel GS	p = 64 bar	332 - 502
	p = 40 bar	662 - 1302
Cast stainless steel 1.4581	p = 40 bar	503
	p = 25 bar	853

5. FILTER CALCULATION / SIZING

The total pressure drop of a filter at a certain flow rate is the sum of the housing Δp (**including change-over valve!**) and the element Δp .

The pressure drop can either be determined with the aid of our Filter Sizing Program, which can be ordered via our website www.hydac.com, or by using the following graphs.

It must be stressed that all of the technical documentation at HYDAC Filtertechnik always gives the total housing pressure drop, i.e. **including change-over valve**.

5.1. ΔP -Q HOUSING GRAPHS (INCLUDING CHANGE-OVER VALVE!) TO ISO 3968

The housing graphs apply to mineral oil with a density of 0.86 kg/dm³ and a kinematic viscosity of 30 mm²/s for, in each case, the largest nominal width per size.

In this case, the differential pressure changes proportionally to the density.

In each case, the Δp given is for the largest possible flange nominal width.

RFLD 111

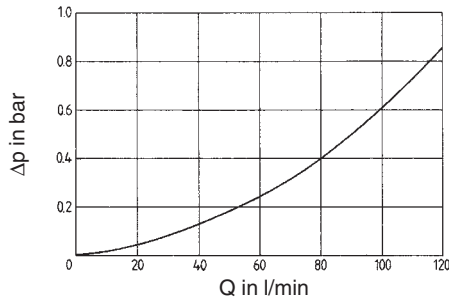

RFLD 241

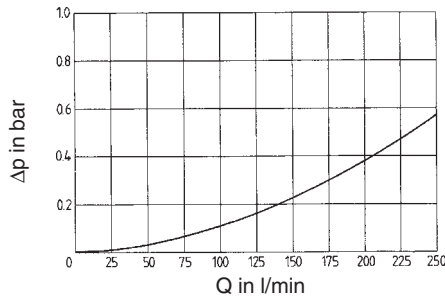

RFLD 331 ... 501

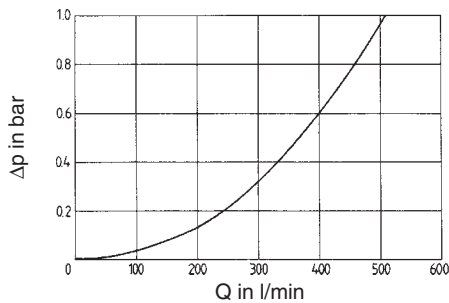

RFLD 661 ... 851

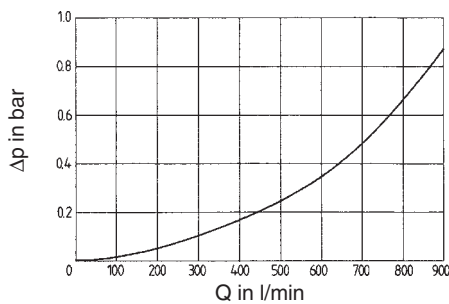

RFLD 951 ... 1301

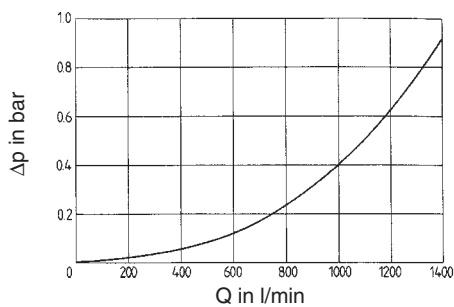

5.2. ΔP -Q GRAPHS - FILTER ELEMENTS

The element graphs apply to mineral oil with a kinematic viscosity of 30 mm²/s. The pressure drop changes proportionally to the change in viscosity (see Example 5.3.).

BN3HC

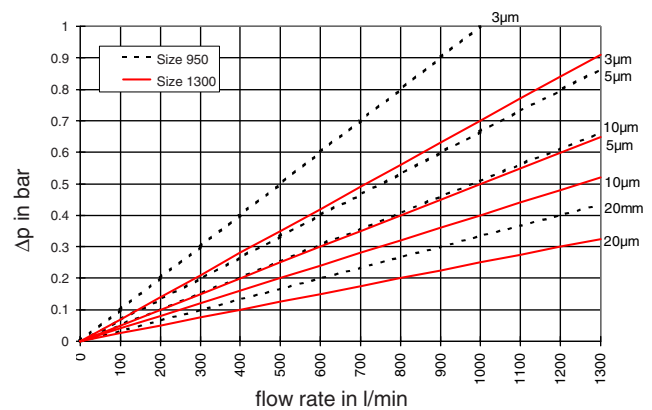
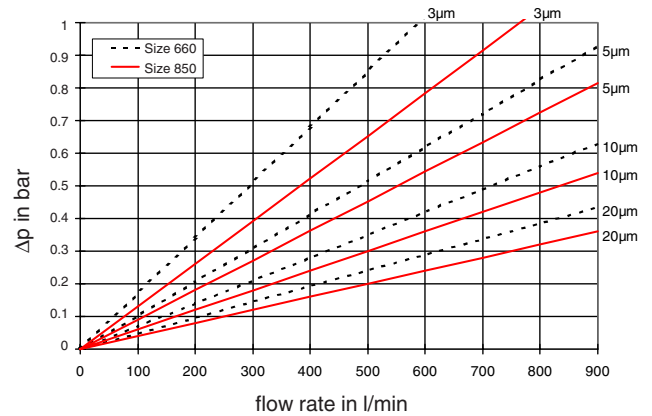
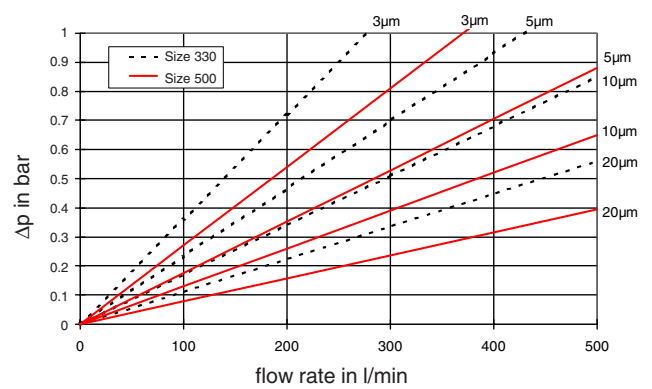
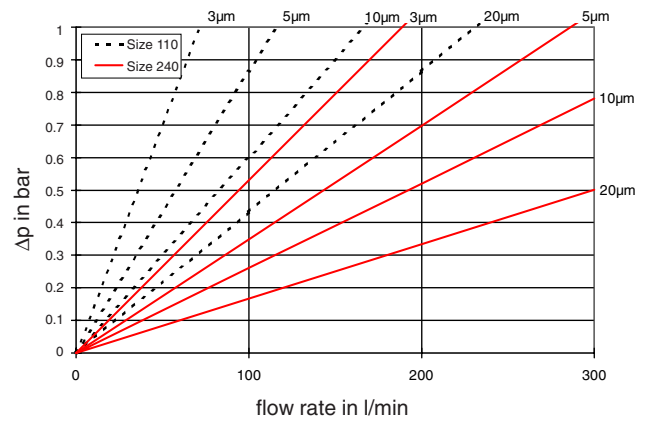

V Element

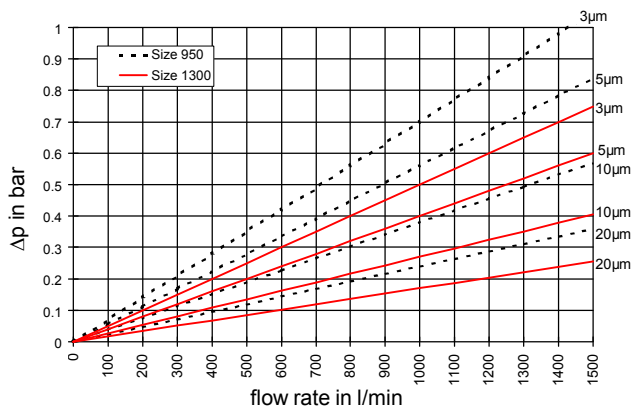
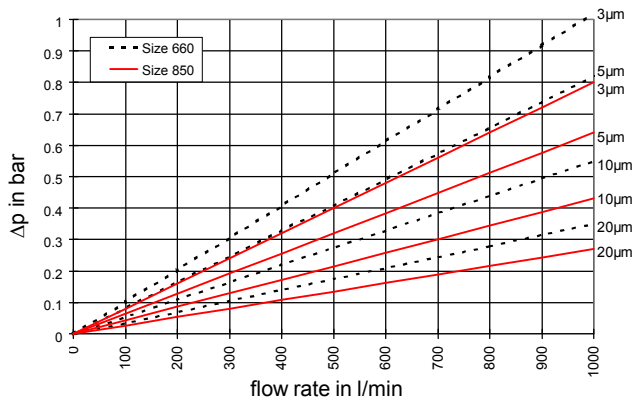
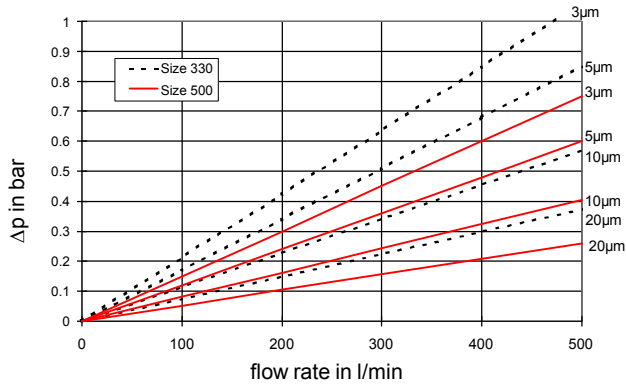
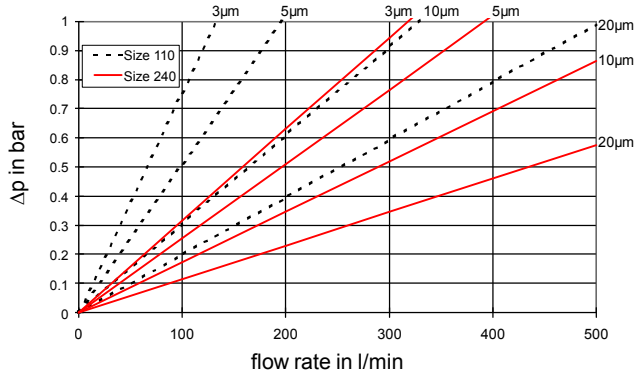

W/HC Element

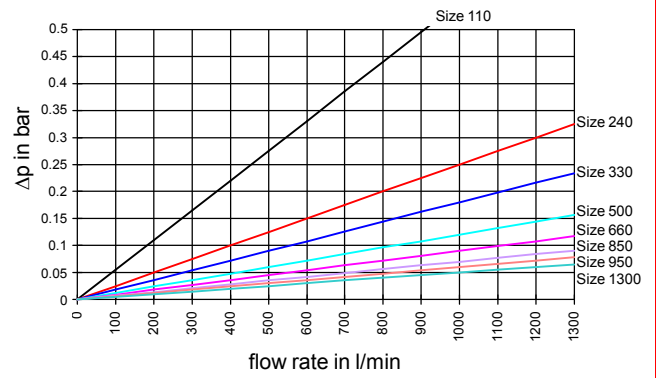

P/HC Element (10 μm P/HC)

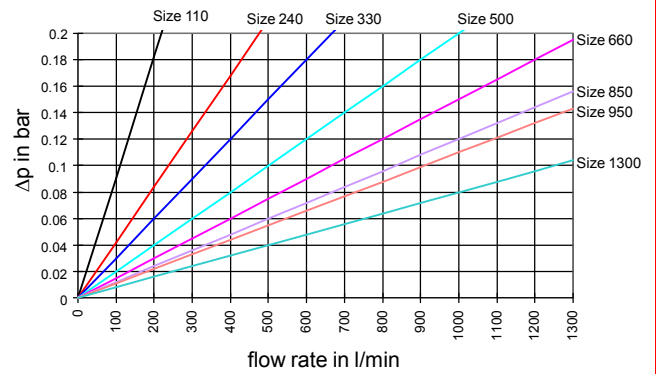

(20 μm)

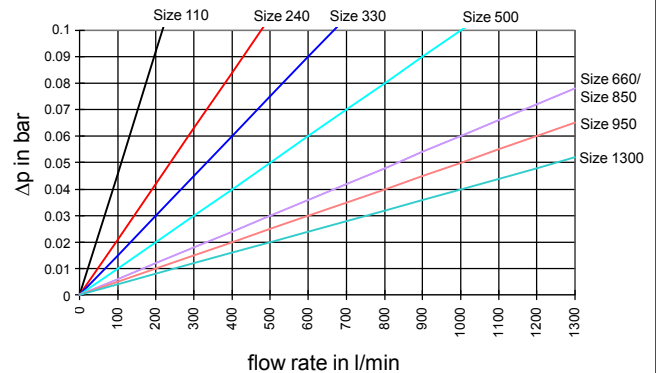

5.3. EXAMPLE

General

$$\Delta p_{\text{total}} = \Delta p_{\text{housing}} + \Delta p_{\text{element}} \times \frac{\text{viscosity (mm}^2/\text{s)}}{30 \text{ mm}^2/\text{s}}$$

$\Delta p_{\text{housing}}$ = to be determined from point 5.1.

$\Delta p_{\text{element}}$ = element pressure drop Q at viscosity 30 mm²/s v according to point 5.2.

Example

System data: Q = 600 l/min; RFLD 661 with W/HC wire mesh element; viscosity = 100 mm²/s (ISO VG 100 at 40 °C)

$$\Rightarrow \Delta p_{\text{housing}} = 0.33 \text{ bar (RFLD 661)}$$

$$\Delta p_{\text{element}} = 0.054 \text{ bar} \times \frac{100 \text{ mm}^2/\text{s}}{30 \text{ mm}^2/\text{s}} = 0.18 \text{ bar}$$

$$\Delta p_{\text{total}} = \Delta p_{\text{housing}} + \Delta p_{\text{element}} = \underline{\underline{0.51 \text{ bar}}}$$

For ease of calculation, our Filter Sizing Program is available and can be ordered via our website www.hydac.com.

6. DIMENSIONS

RFLD 111 - 501

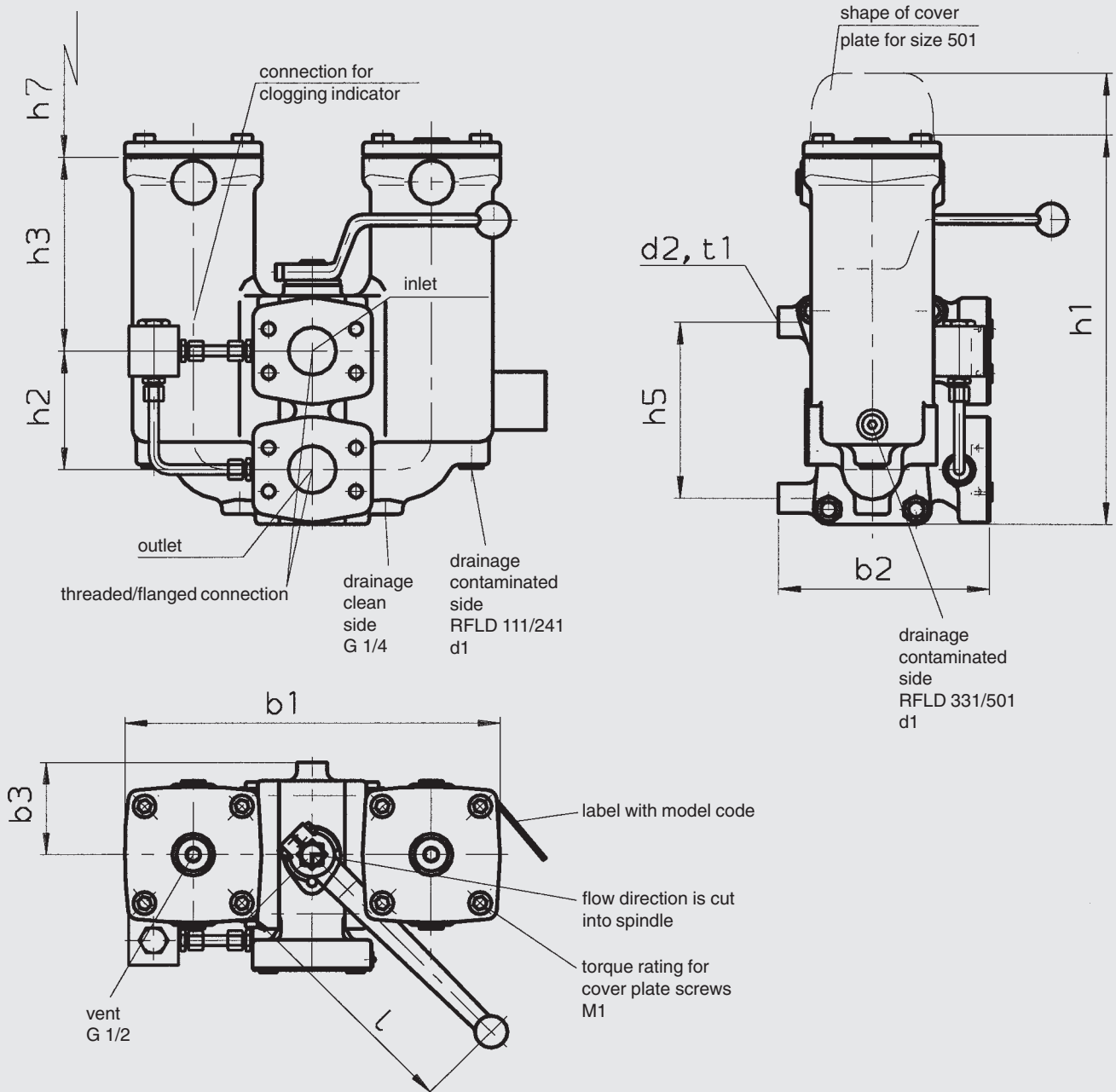

Dimensions in mm

Type	Flanged ¹⁾ connection	Threaded ²⁾ connection	b ₁	b ₂	b ₃	d ₁	d ₂	h ₁	h ₂	h ₃	h ₅	h ₇	l	M ₁ (Nm)	t ₁
RFLD 111	DN 25 (1")	G1	233	157	63	G ¼	M12	263	80	132	80	175	173	24	25
RFLD 241	DN 40 (1 ½")	G 1 ½	302	167	75	G ¼	M12	312	95	155	140	210	216	40	18
RFLD 331	DN 40 (1 ½")	–	396	167	75	G ½	M12	302	95	145	140	200	216	45	18
RFLD 331	DN 50 (2")	–	380	187	85	G ½	M12	323	110	140	165	200	216	45	18
RFLD 501	DN 40 (1 ½")	–	396	167	75	G ½	M12	382	95	145	140	280	216	45	18
RFLD 501	DN 50 (2")	–	380	187	85	G ½	M12	400	110	140	165	280	216	45	18

¹⁾ flanged connection to SAE J 518 C (standard pressure range 3000 psi)

²⁾ threaded connection to ISO 228

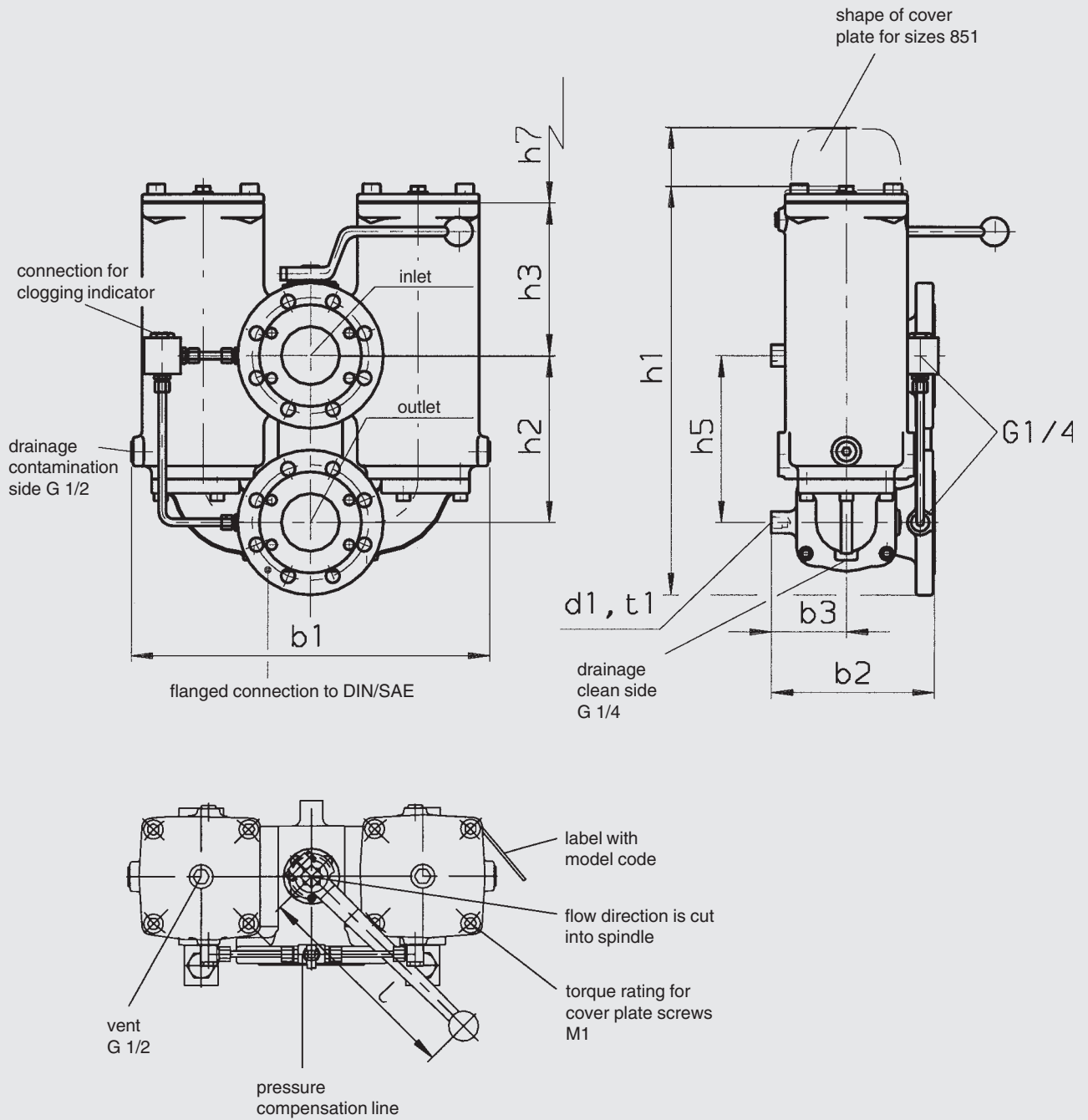

Dimensions in mm

Type	Flanged connection ¹⁾	b ₁	b ₂	b ₃	h ₁	h ₂	h ₃	h ₅	h ₇	l	M ₁ (Nm)	d ₁	t ₁
RFLD 661	DN 50 (2")	496	187	85	460	110	282	165	340	216	150	M12	18
RFLD 661	DN 65 (2 1/2")	496	237	85	472	110	282	165	340	216	150	M12	18
RFLD 661	DN 80 (3")	490	222	102	566	230	210	230	340	301	150	M12	23
RFLD 851	DN 50 (2")	496	187	85	544	110	282	165	420	216	150	M12	18
RFLD 851	DN 65 (2 1/2")	496	237	85	556	110	282	165	420	216	150	M12	18
RFLD 851	DN 80 (3")	490	222	102	650	230	210	230	420	301	150	M12	23
RFLD 951	DN 80 (3")	548	222	102	595	230	243	230	370	301	250	M12	23
RFLD 951	DN 100 (4")	555	248	118	640	250	238	250	370	301	250	M16	23
RFLD 1301	DN 80 (3")	548	222	102	701	230	243	230	490	301	250	M12	23
RFLD 1301	DN 100 (4")	555	248	118	746	250	238	250	490	301	250	M16	23

¹⁾ flanged connection to SAE J 518 C (standard pressure range 3000 psi)
 DIN flange connection to DIN 2501/1 for PN 25/40 (sealing strip "D" or "E")

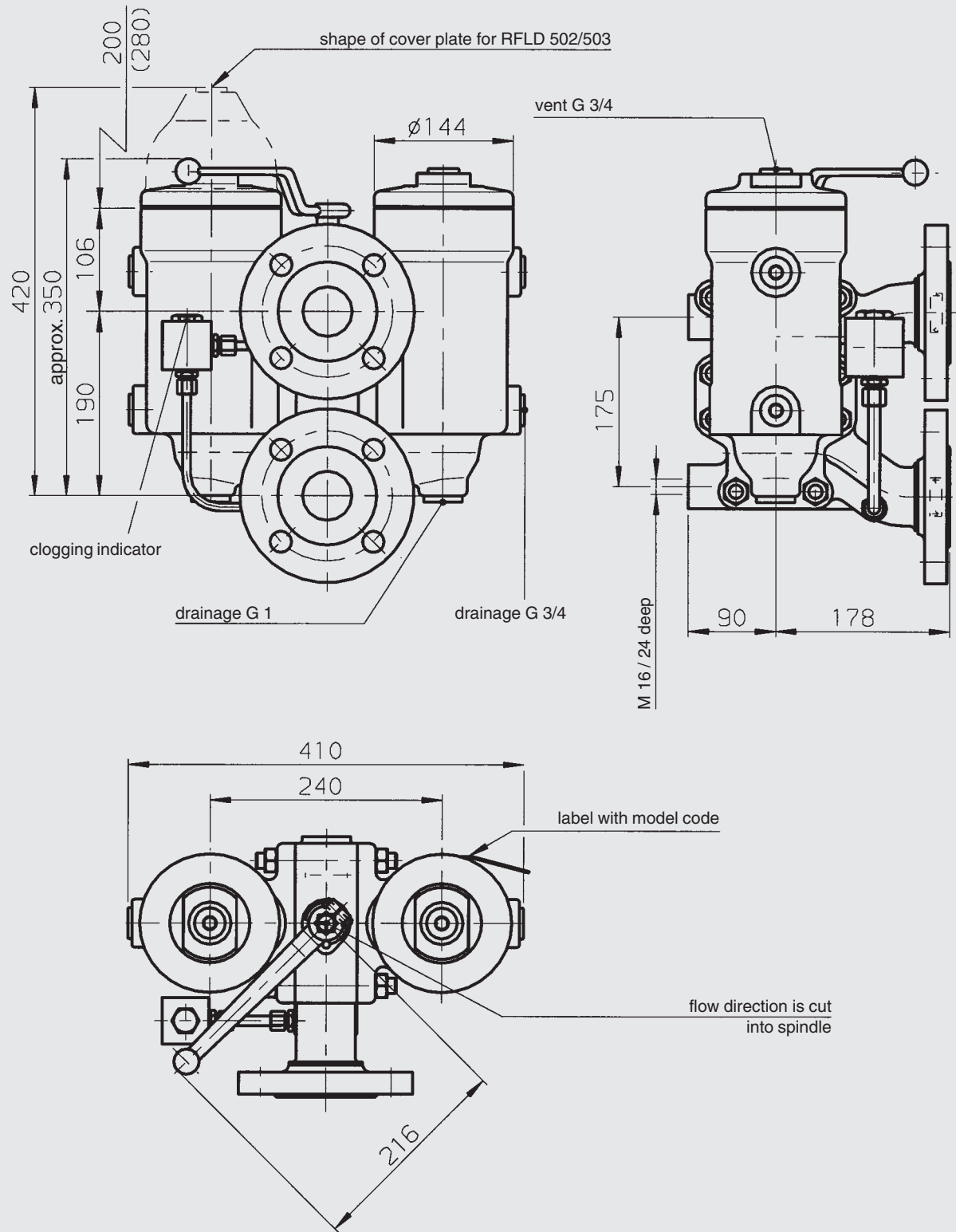

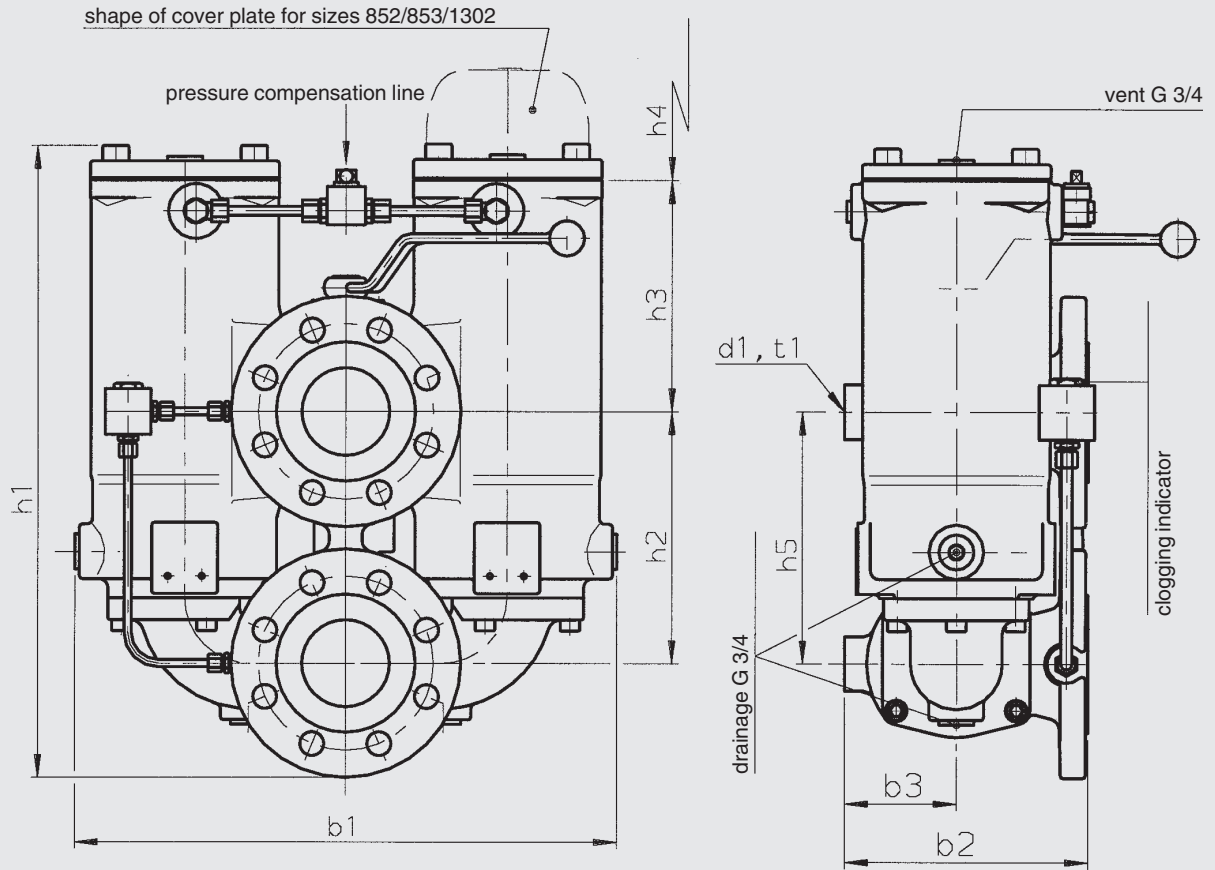

Dimensions in mm

Type	Flanged connection ¹⁾	b ₁	b ₂	b ₃	h ₁	h ₂	h ₃	h ₅	h ₄	l	M ₁ (Nm)	d ₁	t ₁
RFLD 662	DN 80 (3")	495	222	102	574	230	210	230	340	301	150	M12	23
RFLD 852	DN 80 (3")	495	222	102	665	230	210	230	420	301	150	M12	23
RFLD 853	DN 80 (3")	495	222	102	665	230	210	230	420	301	150	M12	23
RFLD 952	DN 100 (4")	573	248	118	672	250	238	250	380	301	250	M16	17
RFLD 1302	DN 100 (4")	573	248	118	745	250	238	250	490	301	250	M16	17

¹⁾ DIN flange connection to DIN 2501/1 for PN 25/40 (sealing strip "D" or "E")

7. NOTE

The information in this brochure relates to the operating conditions and applications described. For applications or operating conditions not described, please contact the relevant technical department. Subject to technical modifications.