

**HYDAC**

**INTERNATIONAL**

Change-Over

## **Inline Filter RFLD**

Welded Version, Steel/Stainless Steel

Flow Rates up to 15,000 l/min

Pressure Range 16 bar

With Ball, Segment or Butterfly Change-Over Valve

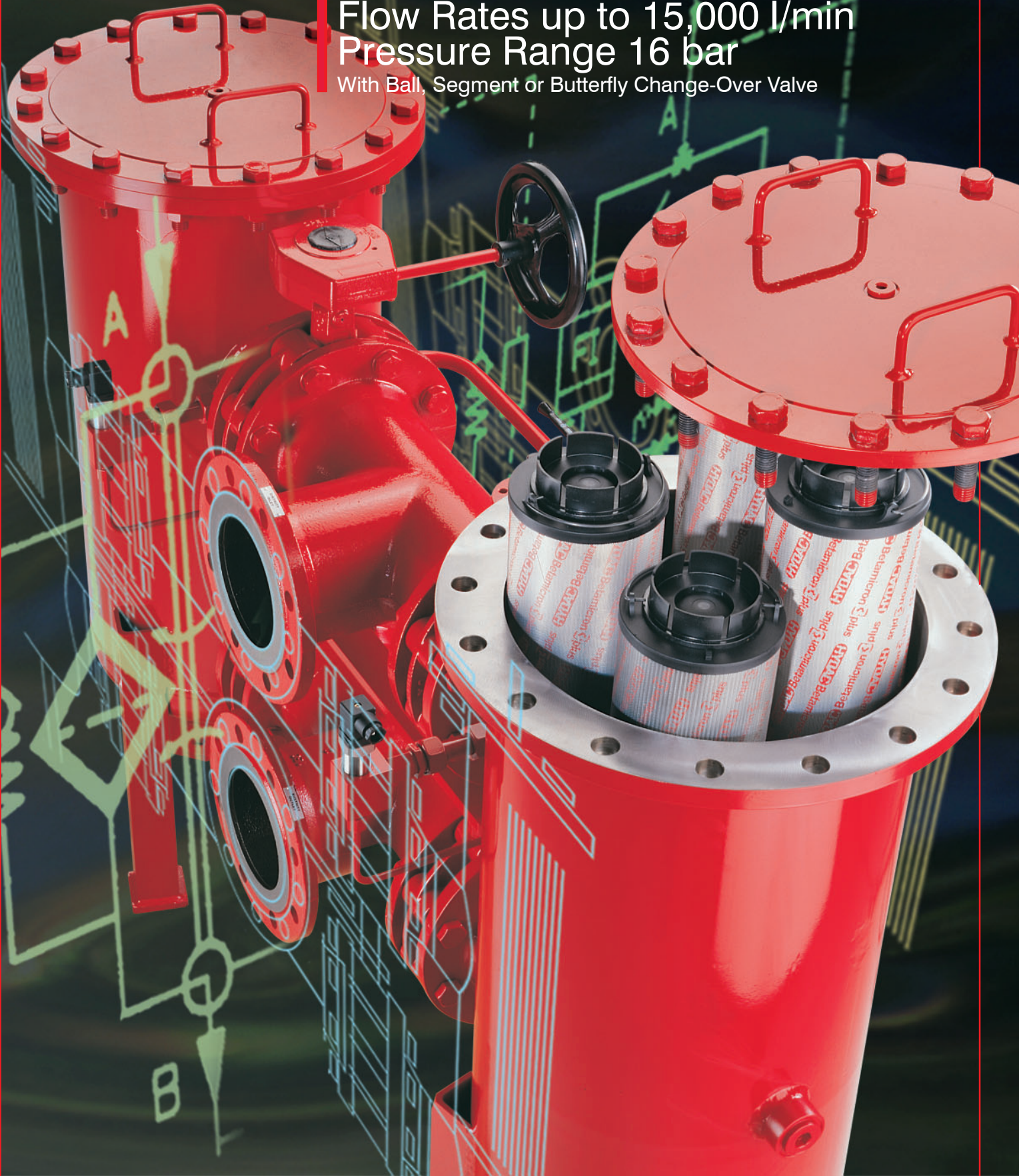

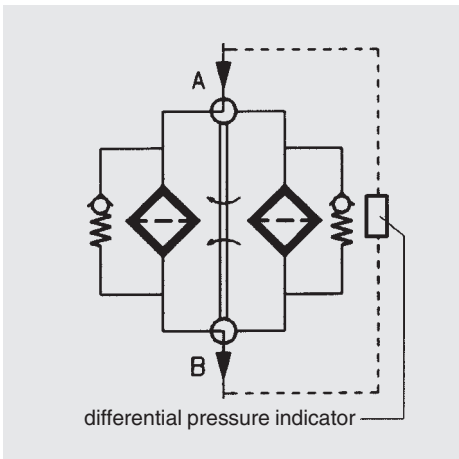

**Hydraulic systems**

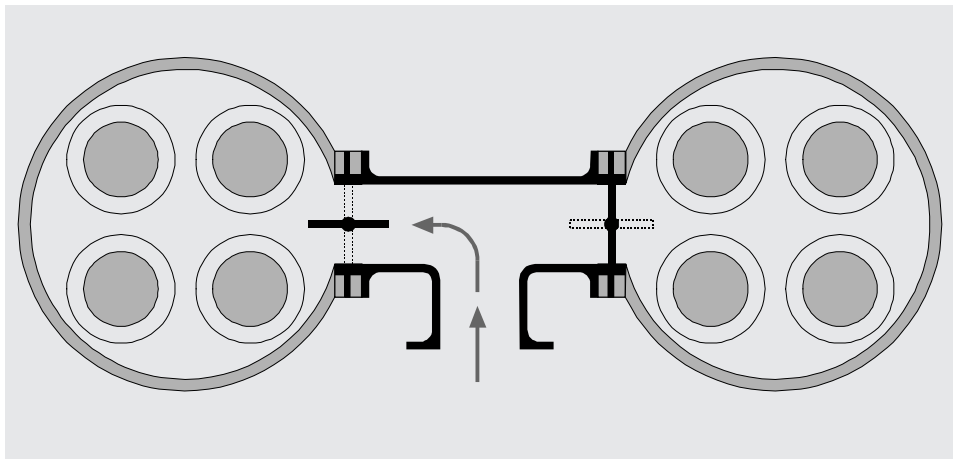

**Butterfly change-over**

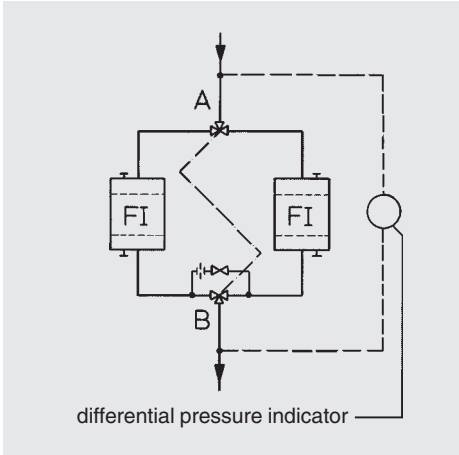

**Lubrication systems**

Change-over inline filters, type RFLD, are designed for inline mounting in hydraulic and lubrication systems which operate non-stop. The filter materials can be selected according to the application.

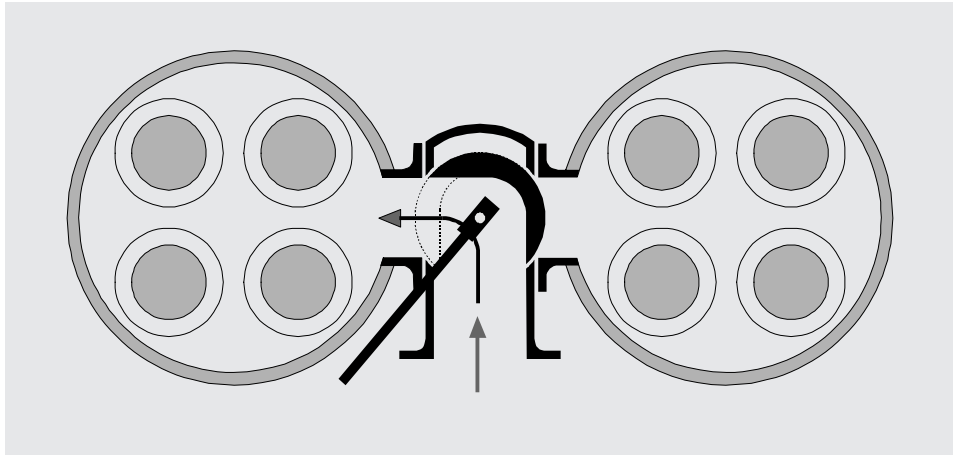

**Ball change-over**

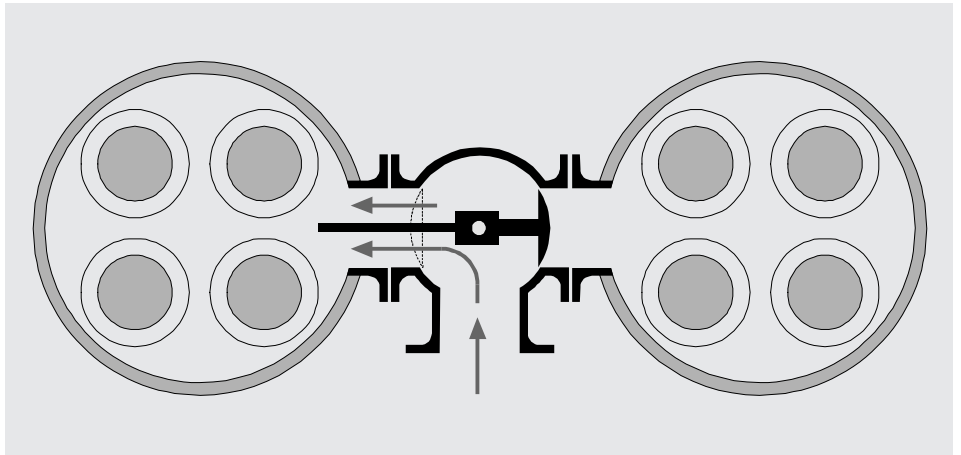

**Segment change-over**

## 1. TECHNICAL SPECIFICATIONS

### 1.1. FILTER HOUSING

#### Construction

The filter housings and connecting elements have been designed in accordance with international regulations.

The two filter housings are connected by means of a change-over valve with negative overlap and single lever operation (ball, segment) or hand-wheel (butterfly).

The pressure compensation between the two filter sides occurs by means of a pressure compensation line.

Connections for venting, draining and for the clogging indicator are part of the standard model.

Filters in the series 1320, 2520...15020 correspond in design to the series 1300, 2500...15000 with twice the element withdrawal height.

A considerably larger contamination retention capacity and higher permissible flow rate are therefore achieved with otherwise identical overall dimensions.

### 1.2. FILTER ELEMENTS

Hydac filter elements meet all ISO test criteria.

**Reliable filter operation is only guaranteed with original HYDAC filter elements.**

The filter elements are also suitable for use in dynamic applications due to their high pressure stability; max. perm.  $\Delta p$  across the element:

Betamicron® (BN3HC)	: 25 bar
Paper (P/HC)	: 10 bar
Wire mesh (W/HC)	: 30 bar
Stainless steel fibre (V)	: 30 bar
Betamicron®/ Aquamicron® (BN/AM)	
(for water removal)	: 10 bar
Aquamicron® (AM)	
(for water removal)	: 10 bar

#### Fluid compatibility

Suitable for mineral oils, lubrication oils, non-flam fluids, synthetic and rapidly biodegradable oils. For use with water, please contact our technical sales department.

For further details on filter elements, please see:  
**brochure no.: E 7.200../..**

### 1.3. CLOGGING INDICATORS

Clogging indicators are fitted as standard between the inlet and outlet of the filter.

Option:  $\Delta p$  measurement across the element.

For further details on clogging indicators, please see:  
**brochure no.: E 7.050../..**

### 1.4. SEALS

Choice of Perbunan (= NBR) or Viton (= FPM for HFD fluids).

### 1.5. SPECIAL MODELS AND ACCESSORIES

- Orifice in the pressure compensation line
- Draining and venting connections with ball valves or other shut-off valves
- Mating flanges available for all sizes
- Change-over valve lockable
- Other sealing materials
- Venting line with sight glasses  
⇒ visual control
- Flanges to DIN 2501 with O-ring seals
- Cover plate lifting device recommended for size 4000 and over

### 1.6. SPARE PARTS

See Original Spare Parts List and Maintenance Instructions.

### 1.7. CERTIFICATION AND APPROVAL

The filters can be supplied with manufacturer's certificates O and M to DIN 55350, Part 18. Test certificates 3.1.B to EN 10204 and material certificates from the approval authorities Germanischer Lloyd (GL), Lloyd's Register (LR), American Bureau of Shipping (ABS), Bureau Veritas (BV) and Det Norske Veritas (DNV) can be supplied.

## 2. GENERAL

### Mounting

Filters must be flexibly mounted and not fixed rigidly to the floor or used as a pipe support.

### Direction of flow

Inlet: above

Outlet: below

On the butterfly change-over, the inlet and outlet can also be opposite one another (inline).

### Temperature range

-10 °C ... +100 °C

Other temperatures on request

### Pressure setting of differential pressure clogging indicator

$\Delta p_a = 2 \text{ bar} - 0.2 \text{ bar}$

Other pressure settings on request

### Cracking pressure of bypass valve

$\Delta p_o = 3 \text{ bar} + 0.5 \text{ bar}$

Other cracking pressures on request

### 3. MODEL CODE

(also order example)

#### 3.1. COMPLETE FILTER

RFLD BN/HC 1300 C A K 10 D 1 . X /-L24

#### Filter type

#### Filter material of element

BN/HC Betamicron® (BN3HC)  
 AM Aquamicron®  
 BN/AM Betamicron®/Aquamicron®  
 P/HC paper  
 W/HC stainless steel wire mesh  
 V stainless steel fibre

#### Size

Welded steel: 1300/ 1320/ 2500/ 2520/ 4000/ 4020/ 5200/ 5220/ 6500/  
 6520/ 7800/ 7820/ 15000/ 15020  
 Stainless steel 1.4571: 1303/1323/ 2503/ 2523/ 4003/ 4023/ 5203/ 5223/ 6503/  
 Separate data sheet 6523/7803/ 7823/ 15003/ 15023

#### Operating pressure

C = 16 bar (size 1300 - 15020, 1303 - 15023)  
 Other operating pressures on request

#### Type of change-over

A ball all nominal widths except for DN 200, 250, 300  
 B segment nominal widths DN 200, 250  
 C butterfly nominal widths DN 150, 200, 250, 300

#### Type of connection / Connection sizes

Type	Connection	Filter size							
		1300 1303	1320 1323	2500 2503 2520 2523	4000 4003 4020 4023	5200 5203 5220 5223	6500 6503 6520 6523	7800 7803 7820 7823	15000 15003 15020 15023
K	SAE DN 40	•	•						
L	SAE DN 50	•	•	•					
M	SAE DN 65	•	•	•					
S	SAE/DIN DN 80	•	•	•	•	•			
T	SAE/DIN DN 100	•	•	•	•	•	•	•	
U	DIN DN 125		•	•	•	•	•	•	
V	DIN DN 150			•	•	•	•	•	
W	DIN DN 200				•	•	•	•	•
X	DIN DN 250					•	•	•	•
Y	DIN DN 300								•

Other nominal widths and ANSI flange versions on request

#### Filtration rating in µm

BN3HC, V : 3, 5, 10, 20  
 BN/AM : 3, 10  
 P/HC : 10, 20  
 W/HC : 25, 50, 100, 200  
 AM : 40

#### Type of clogging indicator

W no port for clogging indicator  
 A without indicator, connection plugged  
 B with visual indicator  
 C with electrical indicator  
 D with combined visual/electrical indicator

for other clogging indicators,  
 see brochure no. E 7.050../..

#### Type code

1

#### Modification number

X filter is always supplied in the latest version

#### Supplementary details

V FPM seals, filter suitable for rapidly biodegradable oils and phosphate ester (HFD-R)  
 L... lamp with corresponding voltage (24V, 48V, 110V, 220V)  
 LED 2 light-emitting diodes up to 24 volts  
 KB without bypass valve  
 B. special bypass cracking pressures (B1 = 1 bar, B6 = 6 bar)  
 SB2 pressure compensation line with 2mm orifice  
 OR O-ring groove on the DIN flange (inlet, outlet) to Rexroth standard AB 22-04  
 DH cover plate lifting device  
 DE differential pressure measurement across the element  
 RE sealing strip E on the flange (inlet and outlet): roughness 3.6 µm  
 - ball change-over, size 150 and over (CAV, CAW, CAX)  
 - butterfly change-over, all sizes  
 - segment change-over, all sizes

### 3.2. REPLACEMENT ELEMENT

1300 R 010 BN3HC /-KB

**Size** \_\_\_\_\_  
 0850, 1300, 1700, 2600 (for element size, see point 4. Filter Specifications)

**Type** \_\_\_\_\_  
 R

**Filtration rating in µm** \_\_\_\_\_  
 BN3HC, V : 3, 5, 10, 20  
 BN/AM : 3, 10  
 P/HC : 10, 20  
 W/HC : 25, 50, 100, 200  
 AM : 40

**Filter material** \_\_\_\_\_  
 BN3HC; V; BN/AM; P/HC; W/HC; AM

**Supplementary details** \_\_\_\_\_  
 V = FPM seals, filter suitable for rapidly biodegradable oils and phosphate ester (HFD-R)  
 W = filter suitable for oil-water emulsions (HFA, HFC), NBR seals  
 KB = without bypass valve  
 B. = special bypass cracking pressures (B1 = 1 bar, B6 = 6 bar)

## 4. FILTER SPECIFICATIONS

Filter type	Connection	Type of change-over	Element size	Number of elements per side	Weight of filter including change-over valve		
					Version A [kg] with elements (ball)	Version B [kg] with elements (segment)	Version C [kg] with elements (butterfly)
1300	SAE DN 40	A	1300 R...	1	105		
	SAE DN 50	A			110		
	SAE DN 65	A			115		
	SAE/DIN DN 80	A			136		
	SAE/DIN DN 100	A			150		
1320	SAE DN 40	A	2600 R...	1	138		
	SAE DN 50	A			143		
	SAE DN 65	A			148		
	SAE/DIN DN 80	A			169		
	SAE/DIN DN 100	A			183		
	DIN DN 125	A			209		
2500/2520	SAE DN 50	A	850 R.../1700 R	3	144 / 174		
	SAE DN 65	A			149 / 179		
	SAE/DIN DN 80	A			170 / 200		
	SAE/DIN DN 100	A			184 / 214		
	DIN DN 125	A			208 / 238		
	DIN DN 150	A+C			262 / 292		
4000/4020	SAE/DIN DN 80	A	850 R.../1700 R	5	210 / 270	464 / 504	313 / 373 393 / 453
	SAE/DIN DN 100	A			222 / 283		
	DIN DN 125	A			246 / 307		
	DIN DN 150	A+C			292 / 352		
	DIN DN 200	B+C					
5200/5220	SAE/DIN DN 80	A	1300 R.../2600 R...	4	384 / 494	646 / 756 890 / 1000	503 / 614 596 / 706 726 / 836
	SAE/DIN DN 100	A			398 / 507		
	DIN DN 125	A			422 / 532		
	DIN DN 150	A+C			476 / 586		
	DIN DN 200	B+C					
	DIN DN 250	B+C					
6500/6520	SAE/DIN DN 100	A	1300 R.../2600 R...	5	628 / 782	877 / 1039 1121 / 1282	738 / 901 826 / 988 956 / 1118
	DIN DN 125	A			652 / 806		
	DIN DN 150	A+C			706 / 868		
	DIN DN 200	B+C					
	DIN DN 250	B+C					
7800/7820	SAE/DIN DN 100	A	1300 R.../2600 R...	6	636 / 798	885 / 1055 1129 / 1298	746 / 917 834 / 1004 964 / 1134
	DIN DN 125	A			660 / 822		
	DIN DN 150	A+C			714 / 884		
	DIN DN 200	B+C					
	DIN DN 250	B+C					
15000/15020	DIN DN 200	B+C	1300 R.../2600 R...	10		1210 / 1380 1454 / 1623	1143 / 1250 1271 / 1379 1487 / 1547
	DIN DN 250	B+C					
	DIN DN 300	C					

Butterfly and segment change-over valves are also available for other nominal widths on request.

## 5. FILTER CALCULATION / SIZING

The total pressure drop of a filter at a certain flow rate is the sum of the housing  $\Delta p$  (including change-over valve!) and the element  $\Delta p$ .

The pressure drop can either be determined with the aid of our FSP Filter Sizing Program, which is available free of charge, or by using the following graphs.

It must be stressed that all of the technical documentation at HYDAC Filtrertechnik always gives the total housing pressure drop, i.e. including change-over valve.

### 5.1. $\Delta P$ -Q HOUSING GRAPHS (INCLUDING CHANGE-OVER VALVE!) TO ISO 3968

The housing graphs apply to mineral oil with a density of  $0.86 \text{ kg/dm}^3$  and a kinematic viscosity of  $30 \text{ mm}^2/\text{s}$ . In this case, the differential pressure changes proportionally to the density.

In each case, the  $\Delta p$  given is for the largest possible flange nominal width; up to size 150 for ball change-over, size 200 and above for butterfly change-over.

#### RFLD 1300

--- without change-over valve  
 — with change-over valve

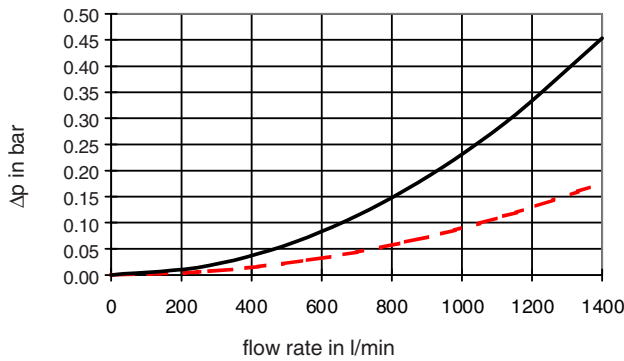

#### RFLD 1320

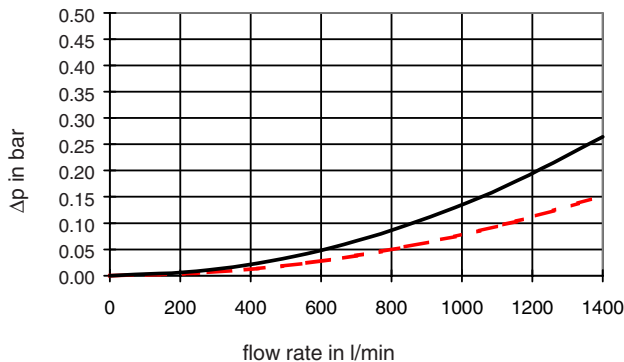

#### RFLD 2500/2520

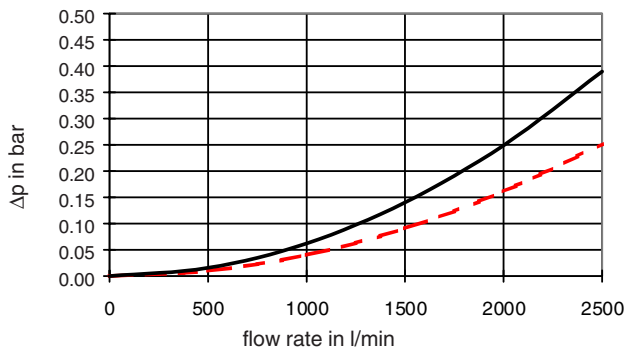

#### RFLD 4000/4020

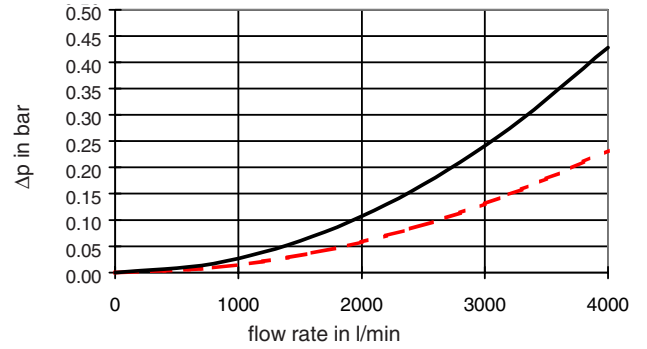

#### RFLD 5200/5220

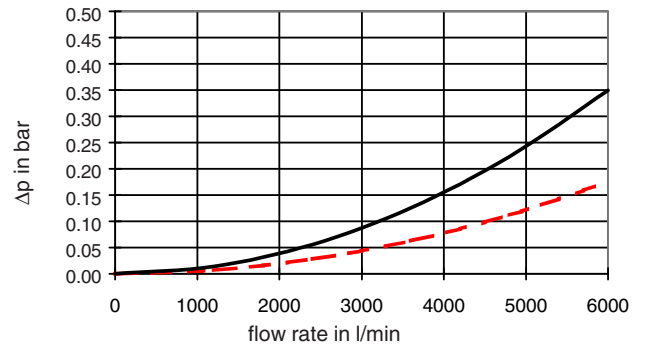

#### RFLD 6500/6520

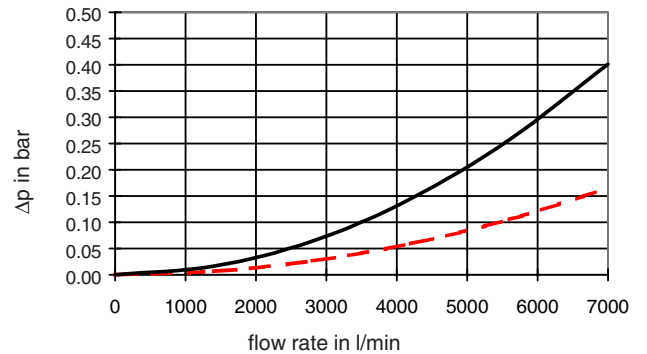

#### RFLD 7800/7820

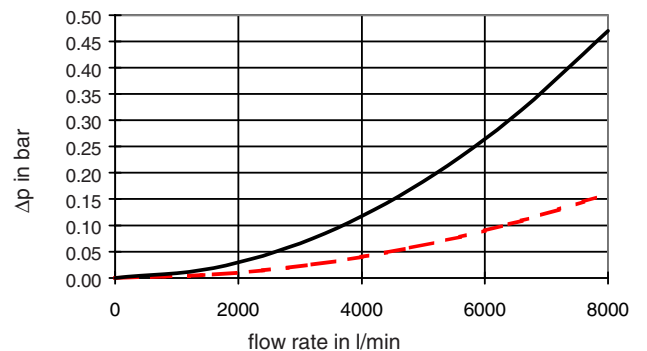

#### RFLD 15000/15020

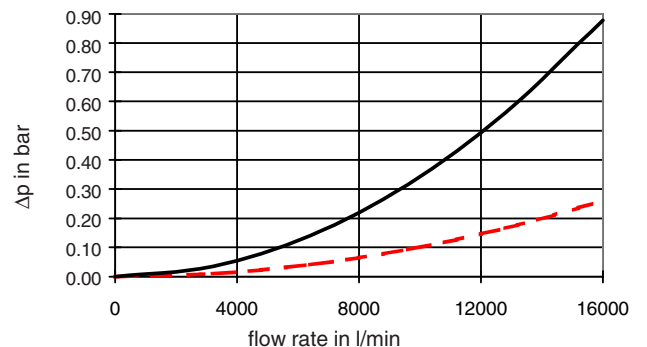

## 5.2. ΔP-Q GRAPHS - FILTER ELEMENTS

The element graphs apply to mineral oil with a kinematic viscosity of 30 mm<sup>2</sup>/s. The pressure drop changes proportionally to the change in viscosity (see Example 5.3.).

The pressure drop for each filter size across the elements at a certain flow rate Q is determined in two stages, as follows:

- 1) Flow rate Q of total filter / n = flow rate per element  
n = number of elements as given under point 4. Filter Specifications
- 2) Read off the Δp at the determined flow rate per element = total pressure drop across the elements for each filter size

BN3HC: element size 850/1300

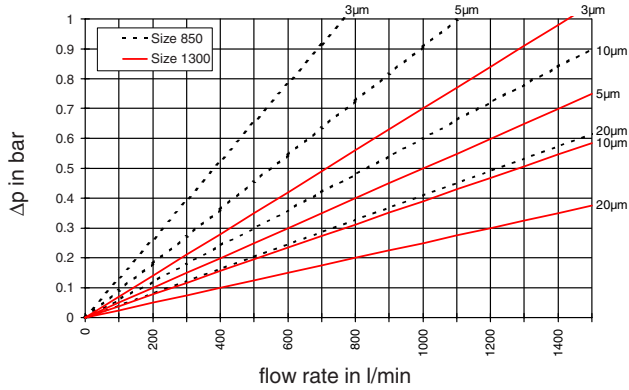

BN3HC: element size 1700/2600

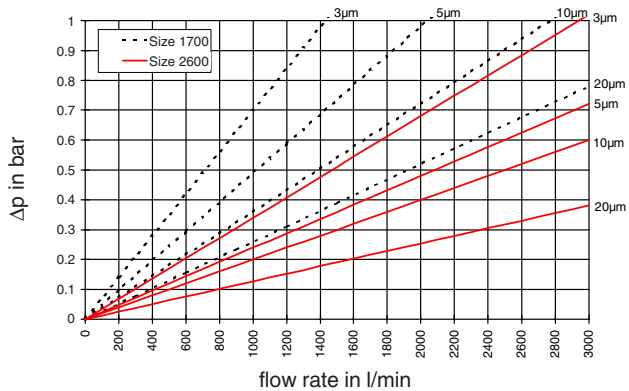

V Element: element size 850/1300

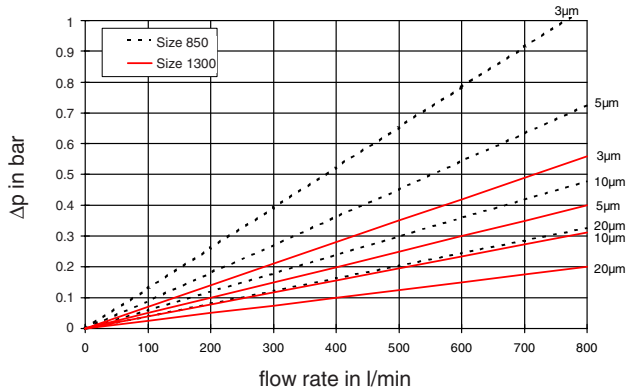

V Element: element size 1700/2600

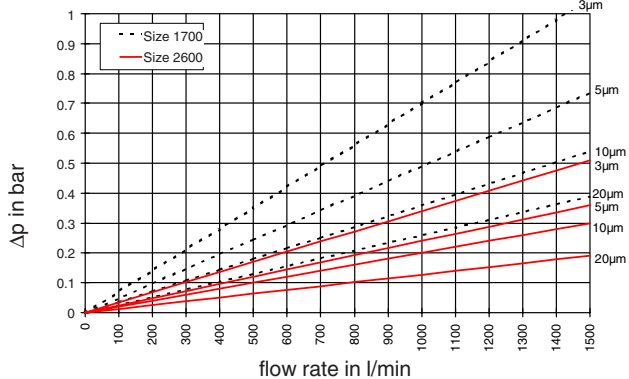

## W/HC Element

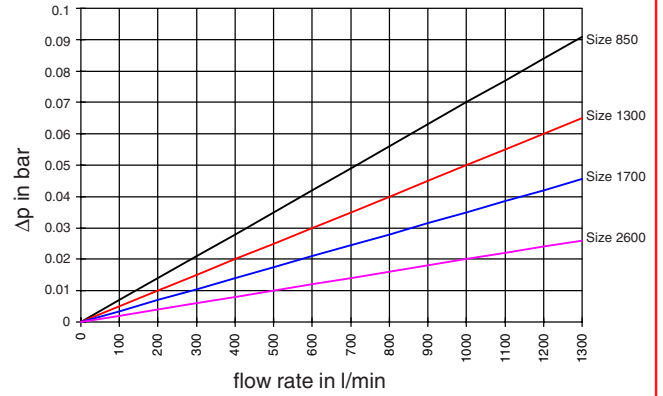

## P/HC Element (10 μm)

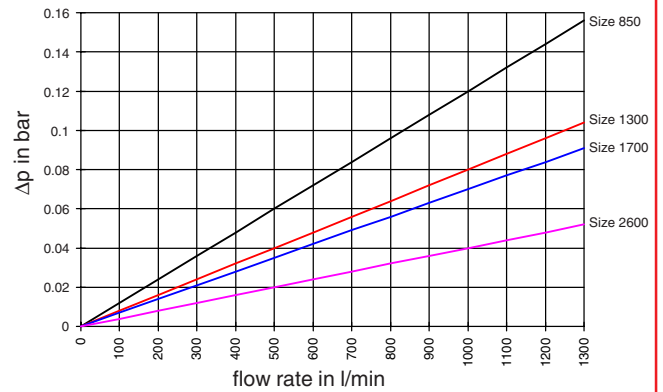

## P/HC Element (20 μm)

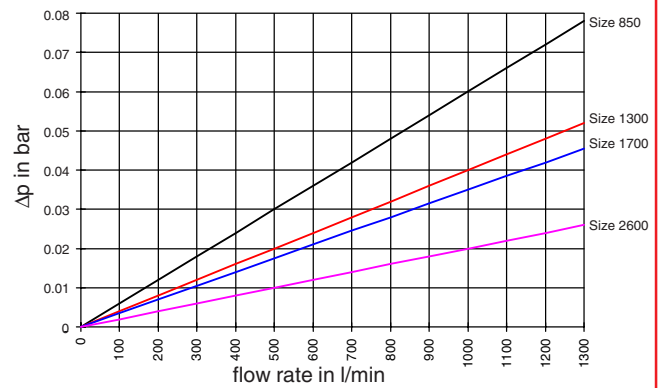

## 5.3. EXAMPLE

### General

$$\Delta p_{\text{total}} = \Delta p_{\text{housing}} + \Delta p_{\text{element}} \times \frac{\text{viscosity (mm}^2/\text{s)}}{30 \text{ mm}^2/\text{s}}$$

$\Delta p_{\text{housing}}$  = to be determined from point 5.1.

$\Delta p_{\text{element}}$  = element pressure drop at flow rate Q/n and viscosity = 30 mm<sup>2</sup>/s determined according to point 5.2.

n = number of elements according to point 4. Filter specifications

### Example

System data: Q = 2500 l/min; RFLD 2520 with W/HC wire mesh element; viscosity = 100 mm<sup>2</sup>/s (ISO VG 100 at 40 °C); Q = 2500 l/min; n = 3 (size 1700) ⇒ Q/n = 833.3 l/min

$$\begin{aligned} \Rightarrow \Delta p_{\text{housing}} &= 0.38 \text{ bar (RFLD 2520)} \\ \Delta p_{\text{element}} &= 0.029 \\ \Delta p_{\text{total}} &= 0.38 \text{ bar} + 0.029 \times \frac{100 \text{ mm}^2/\text{s}}{30 \text{ mm}^2/\text{s}} = \underline{\underline{0.48 \text{ bar}}} \end{aligned}$$

For ease of calculation, our Filter Sizing Program is available and can be downloaded from our website homepage [www.hydac.com](http://www.hydac.com).

## 6. DIMENSIONS

### 6.1. WELDED FILTER SERIES – BALL VERSION RFLD 1300 – 2520 (CHANGE-OVER TYPE A)

#### RFLD 1300/1320

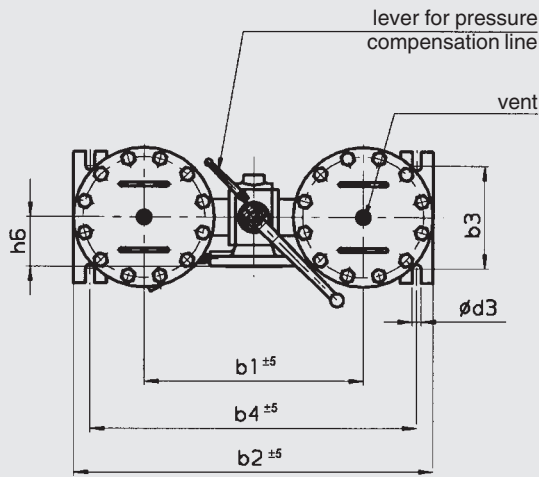
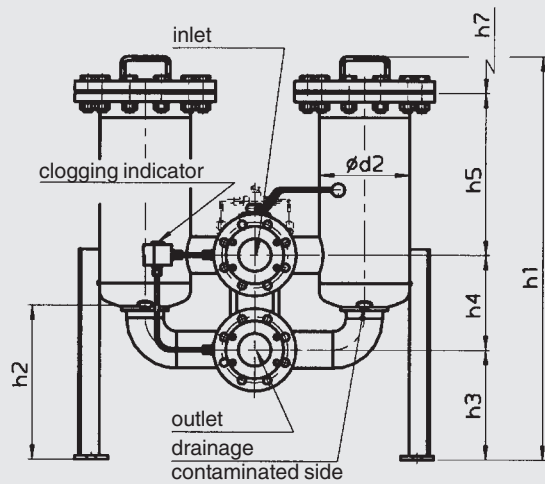

#### RFLD 2500/2520

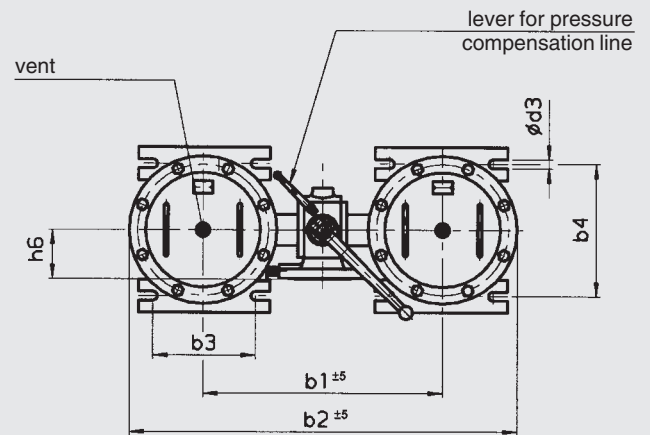
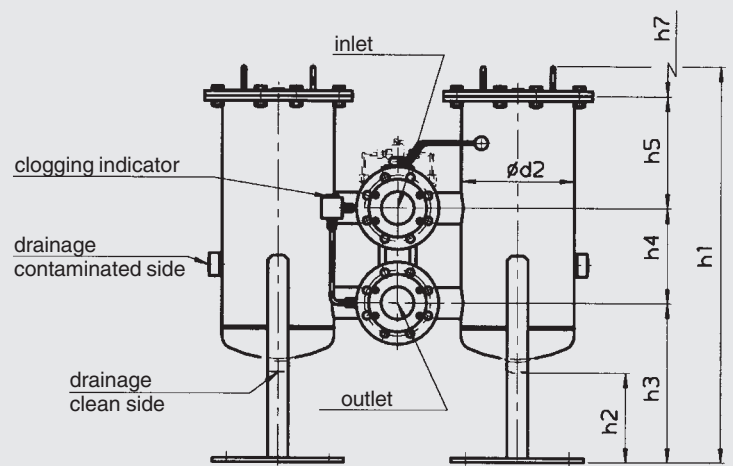

#### Dimensions in mm

Type	Flanged connection <sup>1)</sup>	b <sub>1</sub>	b <sub>2</sub>	b <sub>3</sub>	b <sub>4</sub>	d <sub>2</sub>	d <sub>3</sub>	h <sub>1</sub>	h <sub>2</sub>	h <sub>3</sub>	h <sub>4</sub>	h <sub>5</sub>	h <sub>6</sub>	h <sub>7</sub>
RFLD 1300/1320	SAE DN 40	495	835	250	755	220	22	970/1410	205	335	95	460/900	92	500/940
	SAE DN 50	506	846	250	766	220	22	970/1410	210	328	110	452/892	102	500/940
	SAE DN 65	506	846	250	766	220	22	970/1410	210	328	110	452/892	167	500/940
	SAE/DIN DN 80	530	870	250	790	220	22	970/1410	370	260	230	400/840	120	500/940
	SAE/DIN DN 100	588	926	250	846	220	22	970/1410	375	266	250	374/814	130	500/940
RFLD 1320	DIN DN 125	603	943	250	863	220	22	1536	190	385	300	765	188	940
RFLD 2500/2520	SAE DN 50	548	908	250	312	273	22	940/1330	220	383	110	378/768	102	420/810
	SAE DN 65	548	908	250	312	273	22	990/1380	220	383	230	280/670	167	420/810
	SAE/DIN DN 80	572	932	250	312	273	22	990/1380	220	408	230	280/670	120	420/810
	SAE/DIN DN 100	588	948	250	312	273	22	990/1380	220	408	250	260/650	130	420/810
	DIN DN 125	589	949	250	312	273	22	1050/1440	220	438	300	240/630	188	420/810
	DIN DN 150	641	1001	250	312	273	22	1050/1440	220	438	300	240/630	187	420/810

<sup>1)</sup> flanged connection to SAE J 518 C (standard pressure range 3000 psi)

DIN flange connection to DIN 2501/1 for PN 16 up to DN 125 and PN 25/40 up to DN 100 (sealing strip "D" or "E")

6.2. WELDED FILTER SERIES – BALL VERSION RFLD 4000 – 7820 (CHANGE-OVER TYPE A)

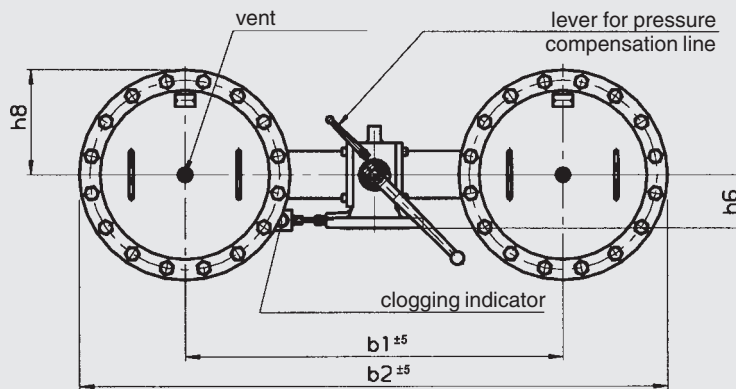
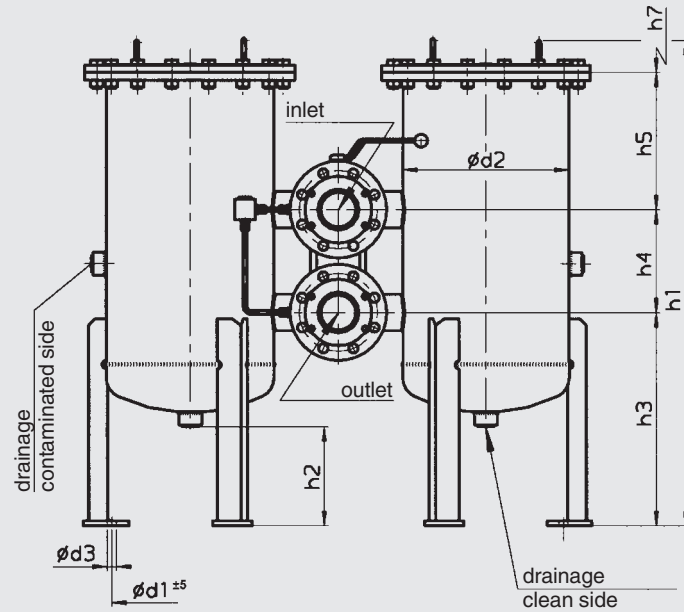

Dimensions in mm

Type	Flanged connection <sup>1)</sup>	b <sub>1</sub>	b <sub>2</sub>	d <sub>1</sub>	d <sub>2</sub>	d <sub>3</sub>	h <sub>1</sub>	h <sub>2</sub>	h <sub>3</sub>	h <sub>4</sub>	h <sub>5</sub>	h <sub>6</sub>	h <sub>7</sub>	h <sub>8</sub>
RFLD 4000/4020	SAE/DIN DN 80	688	1152	330	356	22	1080/1470	260	475	230	295/685	120	420/810	230
	SAE/DIN DN 100	704	1164	330	356	22	1080/1470	260	475	250	275/665	130	420/810	230
	DIN DN 125	723	1183	330	356	22	1170/1560	260	525	300	265/655	188	420/810	230
	DIN DN 150	775	1240	330	356	22	1170/1560	260	525	300	265/655	187	420/810	230
RFLD 5200/5220	SAE/DIN DN 80	728	1244	380	406	22	1144/1584	250	465	230	371/811	120	500/940	255
	SAE/DIN DN 100	744	1260	380	406	22	1144/1584	250	465	250	351/791	130	500/940	255
	DIN DN 125	763	1275	380	406	22	1256/1696	250	525	300	351/791	188	500/940	255
	DIN DN 150	815	1330	380	406	22	1256/1696	250	525	300	351/791	187	500/940	255
RFLD 6500/6520	SAE/DIN DN 100	1024	1644	480	508	22	1260/1700	260	540	250	390/830	130	500/940	310
	DIN DN 125	863	1483	480	508	22	1260/1700	260	540	300	340/780	188	500/940	310
	DIN DN 150	915	1535	480	508	22	1260/1700	260	540	300	340/780	187	500/940	310
RFLD 7800/7820	SAE/DIN DN 100	1024	1644	480	508	22	1260/1700	260	540	250	390/830	130	500/940	310
	DIN DN 125	863	1483	480	508	22	1260/1700	260	540	300	340/780	188	500/940	310
	DIN DN 150	915	1535	480	508	22	1260/1700	260	540	300	340/780	187	500/940	310

<sup>1)</sup> DIN flange connection to DIN 2501/1 for PN 16 up to DN 125 and PN 25/40 up to DN 100 (sealing strip "D" or "E")

### 6.3. RFLD 4000 – 15020 SEGMENT CHANGE-OVER (CHANGE-OVER TYPE B)

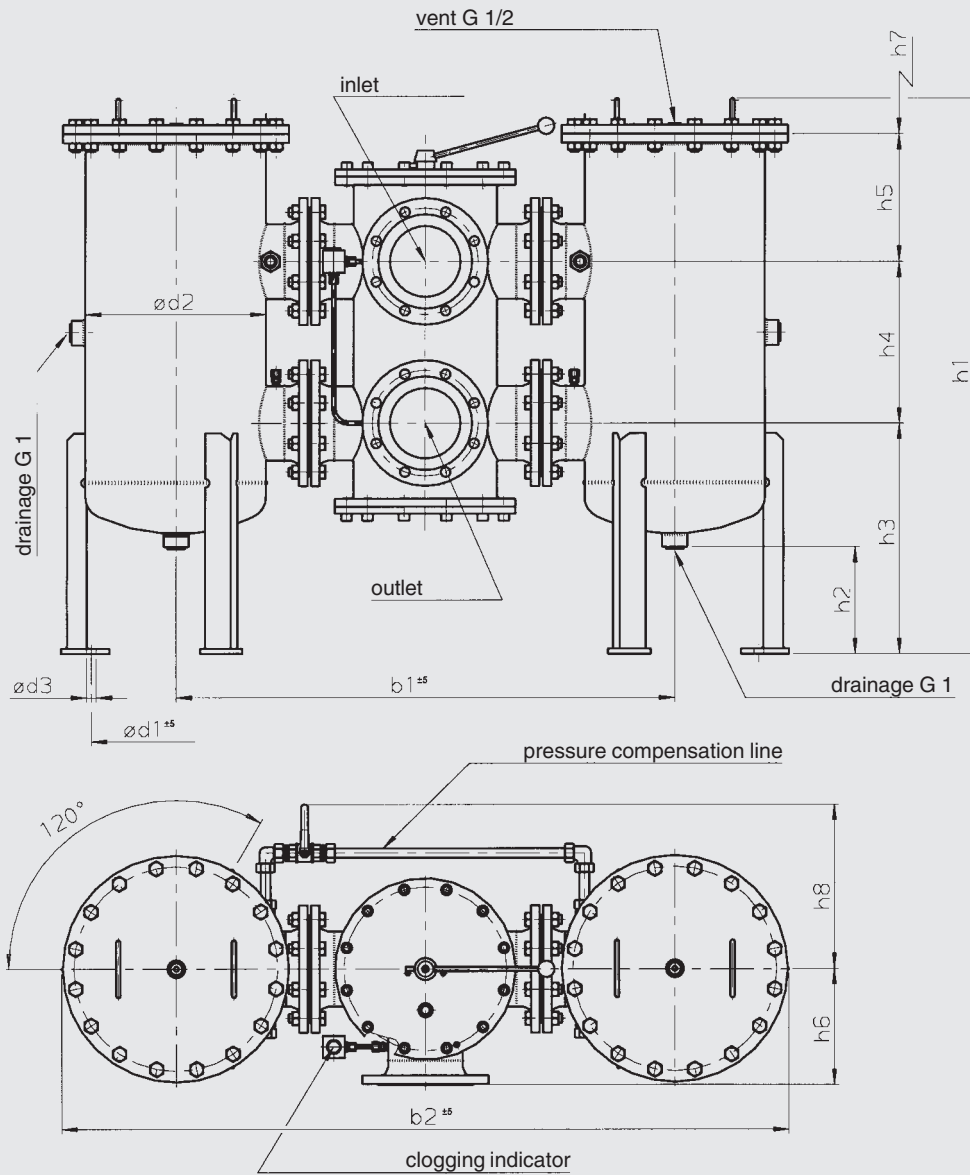

#### Dimensions in mm

Type	Flanged connection <sup>1)</sup>	b <sub>1</sub>	b <sub>2</sub>	d <sub>1</sub>	d <sub>2</sub>	d <sub>3</sub>	h <sub>1</sub>	h <sub>2</sub>	h <sub>3</sub>	h <sub>4</sub>	h <sub>5</sub>	h <sub>6</sub>	h <sub>7</sub>	h <sub>8</sub>
RFLD 4000/4020	DN 200	1124	1590	330	356	22	1250/1595	260	525	365	235/625	261	420/810	370
RFLD 5200/5220	DN 200 DN 250	1166 1312	1680 1825	380 380	406 406	22	1265/1705 1324/1764	250 250	525 560	365 450	286/726 236/676	261 322	500/940 500/940	370 400
RFLD 6500/6520	DN 200 DN 250	1266 1402	1886 2022	480 480	508 508	22	1380/1820 1380/1820	260 260	600 600	365 450	335/775 250/690	261 322	500/940 500/940	370 400
RFLD 7800/7820	DN 200 DN 250	1266 1402	1886 2022	480 480	508 508	22	1380/1820 1380/1820	260 260	600 600	365 450	335/775 250/690	261 322	500/940 500/940	370 400
RFLD 15000/15020	DN 200 DN 250	1506 1628	2016 2458	690 690	711 711	22	1425/1865 1425/1865	263 263	655 640	365 450	330/770 260/700	261 322	500/940 500/940	415 415

<sup>1)</sup> flanged connection to DIN 2501/1 for PN 16 (sealing strip "C")

## 6.4. RFLD 2500 – 15020 BUTTERFLY CHANGE-OVER (CHANGE-OVER TYPE C)

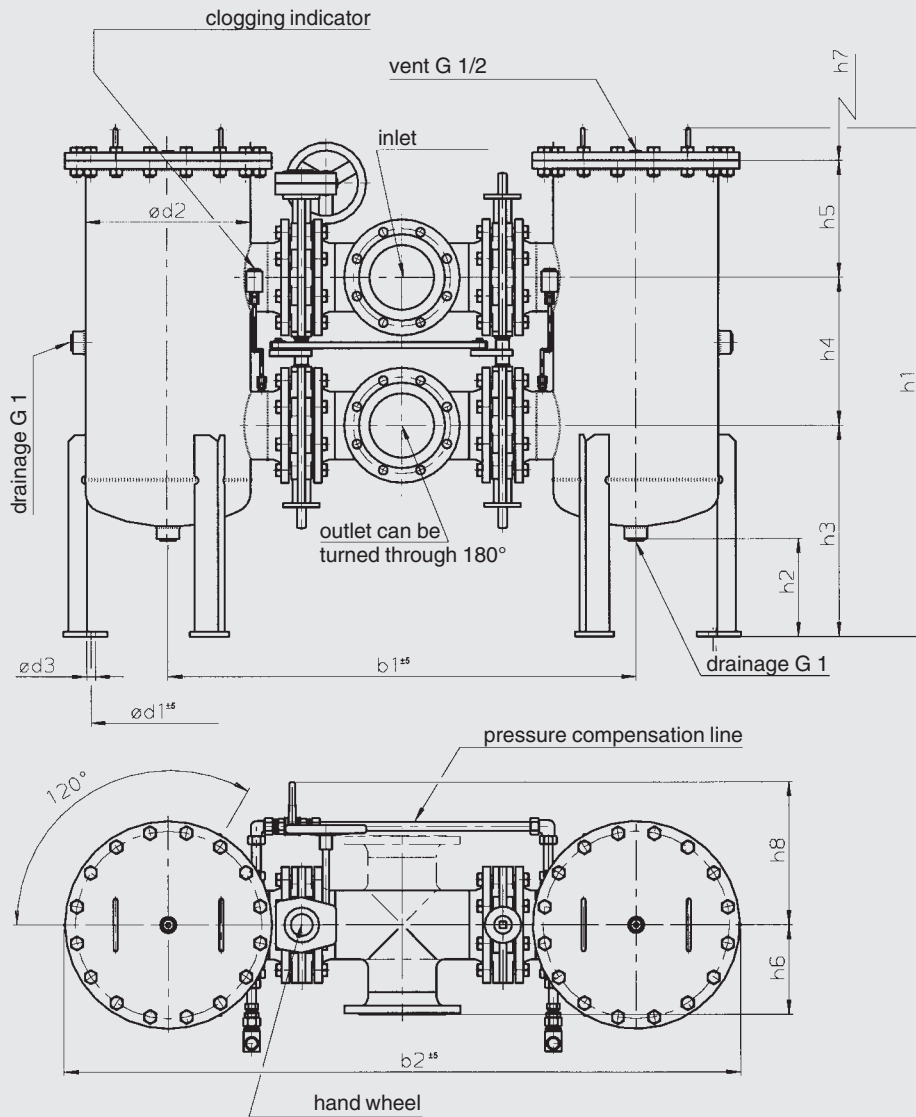

### Dimensions in mm

Type	Flanged connection <sup>1)</sup>	$b_1$	$b_2$	$d_1$	$d_2$	$d_3$	$h_1$	$h_2$	$h_3$	$h_4$	$h_5$	$h_6$	$h_7$	$h_8$
RFLD 2500/2520	DN 150	1018	1378		273	22	1108/1498	220	460	365	211/601	220	420/810	330
RFLD 4000/4020	DN 150	1152	1616	330	356	22	1170/1560	260	525	365	200/590	220	420/810	350
	DN 200	1240	1724	330	356	22	1205/1595	260	525	365	235/625	260	420/810	370
RFLD 5200/5220	DN 150	1152	1666	380	406	22	1256/1696	250	525	365	286/726	220	500/940	350
	DN 200	1280	1794	380	406	22	1256/1696	250	525	365	286/726	260	500/940	370
	DN 250	1496	2010	380	406	22	1326/1766	250	560	450	236/676	350	500/940	400
RFLD 6500/6520	DN 150	1292	1916	480	508	22	1260/1700	260	540	365	275/715	220	500/940	350
	DN 200	1380	2004	480	508	22	1380/1820	260	600	365	335/775	260	500/940	370
	DN 250	1586	2210	480	508	22	1380/1820	260	600	450	250/690	350	500/940	400
RFLD 7800/7820	DN 150	1292	1916	480	508	22	1260/1700	260	540	365	275/715	220	500/940	350
	DN 200	1380	2004	480	508	22	1380/1820	260	600	365	335/775	260	500/940	370
	DN 250	1586	2210	480	508	22	1380/1820	260	600	450	250/690	350	500/940	400
RFLD 15000/15020	DN 200	1620	2450	690	711	22	1425/1865	260	655	365	330/770	260	500/940	370
	DN 250	1816	2646	690	711	22	1425/1865	260	655	450	250/690	350	500/940	400
	DN 300	1956	2786	690	711	22	1500/1940	260	670	515	235/675	400	500/940	430

<sup>1)</sup> DIN flange connection to DIN 2501/1 for PN 16 (sealing strip "C")

## 7. NOTE

The information in this brochure relates to the operating conditions and applications described.  
For applications or operating conditions not described, please contact the relevant technical department.  
Subject to technical modifications.