

HYDAC

INTERNATIONAL

Inline Filter RFL

Cast version

Volume rates up to 1300 l/min*

Pressure range 25/40 bar

RFL inline filters are designed for inline mounting in hydraulic and lubrication systems.

* For larger flow rates, please see brochure: RFL Inline filter, welded version

1. TECHNICAL SPECIFICATIONS

1.1. FILTER HOUSING

Construction

All filters are subject to the Pressure Equipment Directive 97/23/EC and are classified in Article 3, Paragraph 3.

The filters consist of a two-piece filter housing with a screw-on cover plate. This two-part construction enables the inlet and outlet to be positioned either one above the other, or at different heights on opposite sides.

Vent, drain and clogging indicator ports are standard.

1.2. FILTER ELEMENTS

Original HYDAC filter elements guarantee reliable function and protection from wear for contamination-sensitive hydraulic components and systems.

HYDAC filters are validated and their quality is continuously monitored according to the following standards:

- DIN ISO 2941: Verification of collapse/burst resistance
- DIN ISO 2942: Verification of fabrication integrity and determination of first bubble point
- DIN ISO 2943: Verification of material compatibility with fluids
- ISO 3724: Verification of flow fatigue characteristics
- ISO 3968: Evaluation of pressure drop versus flow characteristics
- ISO 4572/ISO16889: Multi-pass method for evaluating filtration performance

In addition to guaranteeing retention and flow rate characteristics, the filter elements have excellent structural stability. The careful construction and mechanically stable support of the filter media guarantee above-average beta value stability and flow fatigue characteristics of the filter elements.

The filter elements are available with the following collapse/burst stability values:

- Betamicon® / Aquamicon® (BN/AM) : 10 bar
- Betamicon® (BN3HC) : 25 bar
- Aquamicon® (AM) : 10 bar
- Paper (P/HC) : 10 bar
- Wire mesh (W/HC) : 30 bar
- Stainless steel fibre (V) : 30 bar

1.3. CLOGGING INDICATORS

Type of indicator

VM = differential pressure measurement up to 210 bar

Pressure setting

2 = 2 bar standard

Indicator type

- B. = visual
- C. = electrical
- D. = visual/electrical

Modification number

0 = the latest version is always supplied

Supplementary details

- V = FPM seals, filter suitable for rapidly biodegradable oils and phosphate ester (HFD-R)
- LED 2 light emitting diodes up to 24 volt
- L.. light with corresponding voltage (24, 48, 110, 220 Volt)
- W.. filter suitable for oil-water emulsions

For further details and other types of clogging indicator, please see **brochure, no. E 7.050./..**

1.4. SEALS

Perbunan (= NBR) or Viton (= FPM for HFD-oils)

1.5. SPECIAL MODELS AND ACCESSORIES

On request

1.6. SPARE PARTS

See Original Spare Parts List and Maintenance Instructions.

1.7. COMPATIBILITY WITH OPERATING FLUIDS

DIN ISO 2943

- Hydraulic oils H to HLPD to DIN 51524
- Lubrication oils to DIN 51517, APJ, ACEA, DIN 51515, ISO 6743
- Compressor oils to DIN 51506
- Rapidly biodegradable operating fluids to VDMA 24568 HETG, HEES, HEPG
- Non-flam operating fluids HFC and HFD
- Operating fluids with high water content (>50% water content) on request

For further details on filter elements:

Brochure no.: E 7.200./..

1.8. CERTIFICATES AND APPROVALS

The filters can be supplied with a manufacturer's certificate O and M according to DIN 55350, part 18 (please request other certificates separately). Inspection certificates 3.1 B to EN 10204 and approval certificates from the inspection agencies Germanischer Lloyd (GL), Lloyd's Register (LR), American Bureau of Shipping (ABS), Bureau Veritas (BV) and Det Norske Veritas (DNV) are possible.

2. GENERAL

Mounting

Filters must be flexibly mounted and not fixed rigidly to the floor or used as a pipe support.

Temperature range

-10 °C to +100 °C

Pressure setting of the inline clogging indicator

$\Delta p_a = 2 \text{ bar} -0.2 \text{ bar}$

Other pressure settings on request

Cracking pressure of the bypass valve

$\Delta p_o = 3 \text{ bar} +0.5 \text{ bar}$

Other cracking pressures on request

Hydraulic symbol

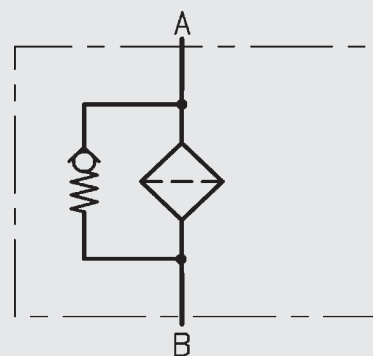

3. MODEL CODE

(also order example)

3.1. COMPLETE FILTER

RFL BN/HC 661 D N 10 D 1 . X /-L24

Filter type

Filter material of element

BN/HC Betamicron® (BN3HC)
 AM Aquamicon®
 BN/AM Betamicron®/Aquamicon®
 P/HC Paper
 W/HC Wire mesh
 V Stainless steel fibre

Material/size

GGG40 (SGM cast iron): 661/851/951/1301/1321*
 GSC25N (cast steel): 662/952/1302/1322*
 1.4581/4571 (stainless steel): 853

Operating pressure

D 25 bar
 E 40 bar (only for 662-1322 to AD Notice)

Type / Size of port

Type	Port	Filter size				
		661 662	851 853	951 952	1301 1302	1321 1322
N	SAE DN 80	●	●			
P	SAE DN 100			●	●	●
Q	DIN DN 80	●	●			
R	DIN DN 100			●	●	●

Other nominal widths, or ANSI ports on request.

Filtration rating in µm

BN3HC, V : 3, 5, 10, 20
 BN/AM : 3, 10
 P/HC : 10, 20
 W/HC : 25, 50, 100, 200
 AM : 40

Type of clogging indicator

A without clogging indicator, with blanking plug
 B with visual clogging indicator
 C with electrical clogging indicator
 D with visual and electrical clogging indicator
 W no port for clogging indicator

for other clogging indicators see brochure no. 7.050

Type code

1

Modification number

X the latest version is always supplied

Supplementary details

V FPM seals, filter suitable for rapidly biodegradable oils and phosphate ester (HFD-R)
 L light with appropriate voltage (24V, 48V, 110V, 220V)
 LED 2 light emitting diodes up to 24 volt
 KB without bypass valve
 B special bypass valve cracking pressures (B1 = 1 bar, B6 = 6 bar, B0.2 = 0.2 bar)
 OR O-ring groove on the DIN flange (inlet and outlet) to Rexroth standard AB 22-04
 GA counter flange as welding flange
 GB counter flange as blank flange
 33 inlet and outlet positioned one above the other

* For sizes 1321/1322 the extension is made of steel

3.2. REPLACEMENT ELEMENT

0600 R 010 BN3HC /-KB

Size _____
0660, 0850, 0950, 1300, 2600

Type _____
R

Filtration rating in µm _____
BN3HC, V : 3, 5, 10, 20
BN/AM : 3, 10
P/HC : 10, 20
W/HC : 25, 50, 100, 200
AM : 40

Filter material _____
BN3HC, V, P/HC, W/HC, BN/AM, AM

Supplementary details _____
V = FPM seals, filter suitable for rapidly biodegradable oils and phosphate ester (HFD-R)
W = NBR seals, filter suitable for oil-water emulsions (HFA, HFC) (only on W/HC, P/HC and V elements)
KB = without bypass valve
B. = special bypass cracking pressure (B1 = 1 bar, B6 = 6 bar, B0.2 = 0.2 bar)

4. FILTER SPECIFICATIONS

Filter type	Port	Element size	Number of elements	GGG40 Filter weight [kg] with elements	GSC25N Filter weight [kg] with elements	1.4581 Filter weight [kg] with elements
661 / 662	SAE DN 80 DIN DN 80	0660 R...	1	36.0	42.0	–
851 / 853	SAE DN 80 DIN DN 80	0850 R...	1	38.5	–	45.0
951 / 952	SAE DN 100 DIN DN 100	0950 R...	1	54.0	67.5	–
1301 / 1302	SAE DN 100 DIN DN 100	1300 R...	1	55.5	75.5	–
1321 / 1322	SAE DN 100 DIN DN 100	2600 R...	1	82.0	96.0	–

5. FILTER CALCULATION / SIZING

The total pressure drop of a filter at a certain flow rate is the sum of the housing Δp and element Δp .

The pressure drop can be determined either with the aid of our Filter Sizing Program FSP, which is available free of charge, or by using the following graphs.

5.1. ΔP -Q HOUSING GRAPHS BASED ON ISO 3968

The housing graphs apply to mineral oil with a density of 0.86 kg/dm^3 and a kinematic viscosity of $30 \text{ mm}^2/\text{s}$.

In this case, the differential pressure changes proportionally to the density.

In each case Δp is given for the largest possible flange nominal width.

RFL 661/662/851/853

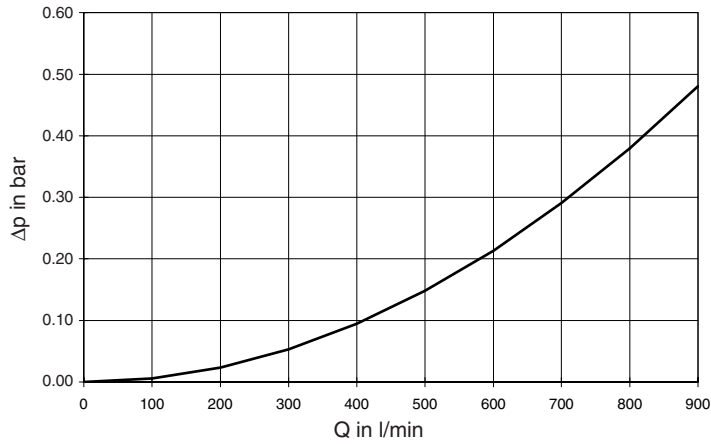

RFL 951/952/1301/1302/1321/1322

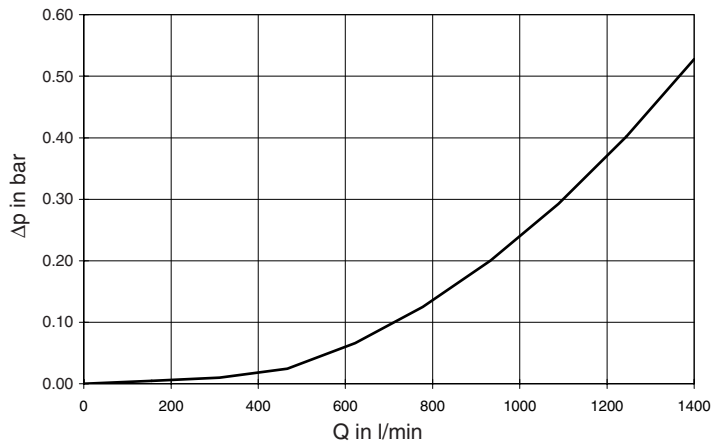

5.2. ΔP -Q GRAPHS - FILTER ELEMENTS

The element graphs apply to mineral oil with a kinematic viscosity of $30 \text{ mm}^2/\text{s}$.

The pressure drop changes proportionally to the change in viscosity (see example 5.3.).

BN3HC: Size 660, 850

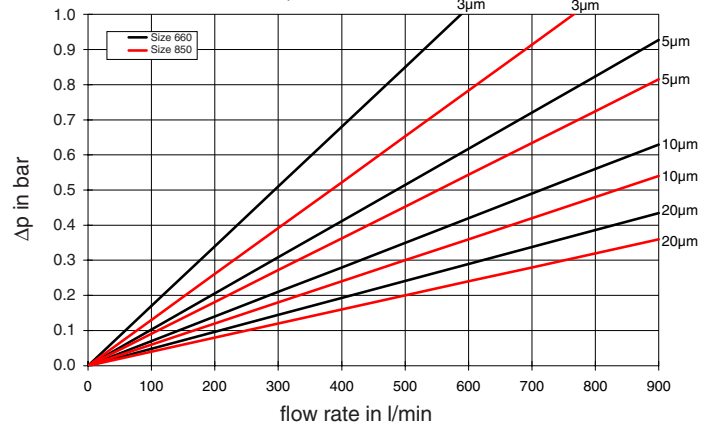

BN3HC: Size 950, 1300, 2600

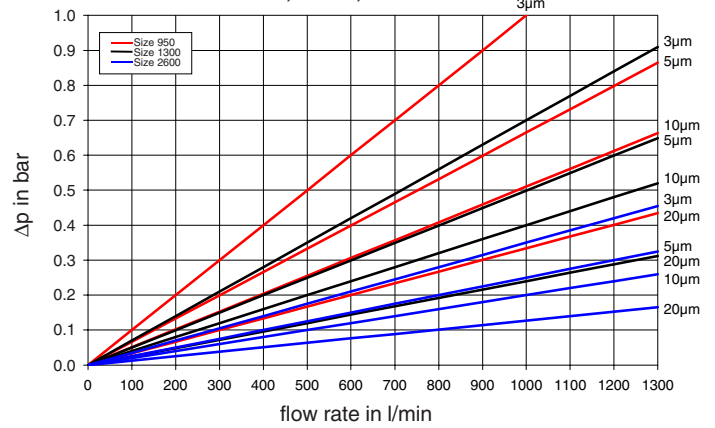

V: Size 660, 850

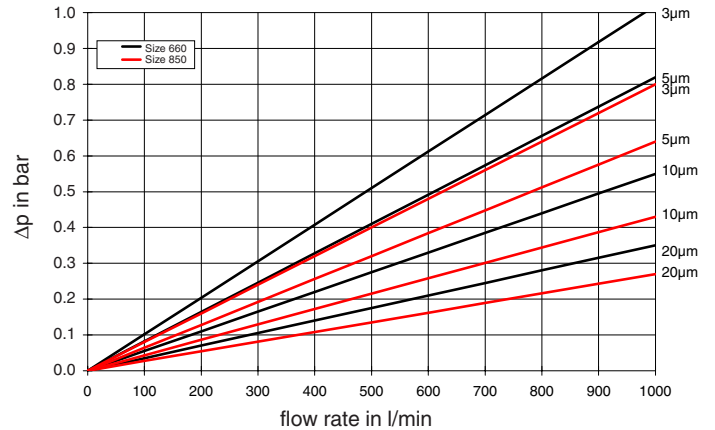

V: Size 950, 1300, 2600

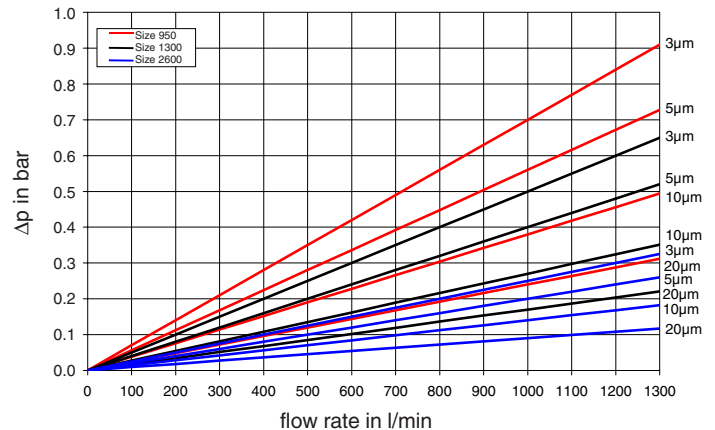

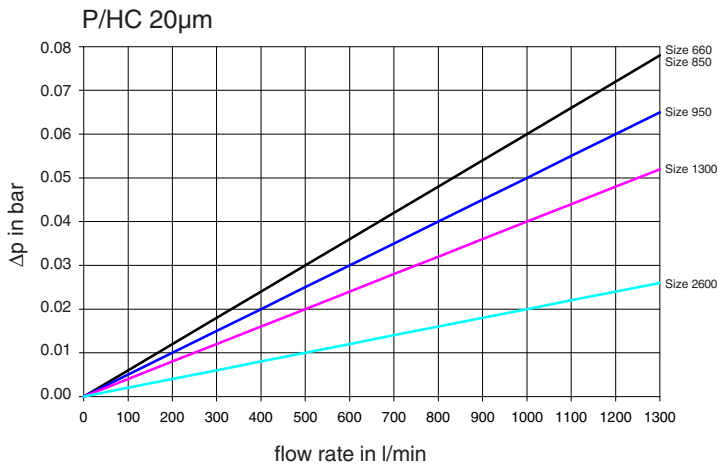
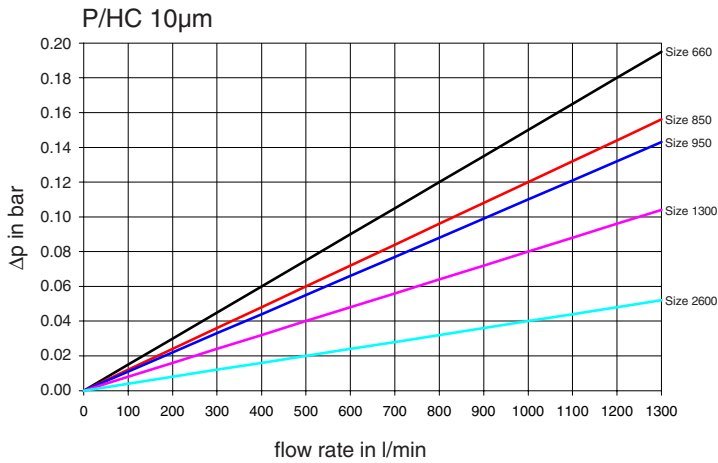
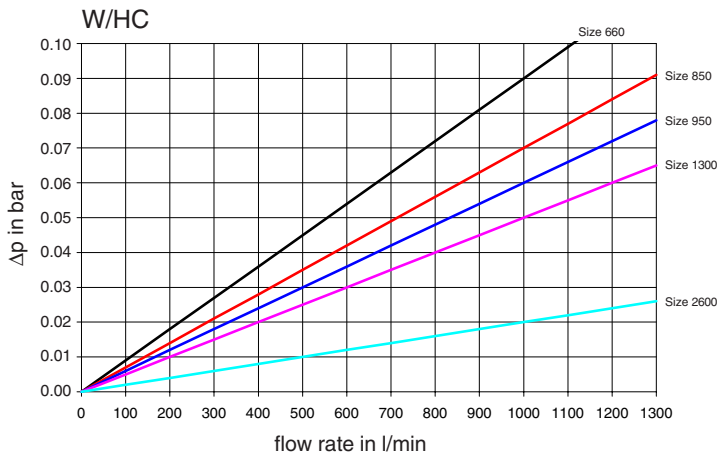

5.3. EXAMPLE

General:

$$\Delta p_{\text{total}} = \Delta p_{\text{housing}} + \Delta p_{\text{element}} \times \frac{\text{viscosity (mm}^2/\text{s)}}{30 \text{ mm}^2/\text{s}}$$

$\Delta p_{\text{housing}}$ = see point 5.1.

$\Delta p_{\text{element}}$ = element pressure drop at flow rate Q and viscosity = 30 mm²/s see point 5.2.

Example:

System data:

RFL 951 with W/HC - wire mesh element;

Viscosity = 100 mm²/s (ISO VG 100 at 40 °C)

Q = 900 l/min

⇒ $\Delta p_{\text{housing}}$ = 0.18 bar (RFL 951)

$\Delta p_{\text{element}}$ = 0.053

$$\Delta p_{\text{total}} = 0.18 \text{ bar} + 0.053 \times \frac{100 \text{ mm}^2/\text{s}}{30 \text{ mm}^2/\text{s}} = 0.36 \text{ bar}$$

For ease of calculation, our FSP Filter Sizing Program is available and can be downloaded from our website homepage www.hydac.com.

6. DIMENSIONS

6.1. RFL 661 - 1322

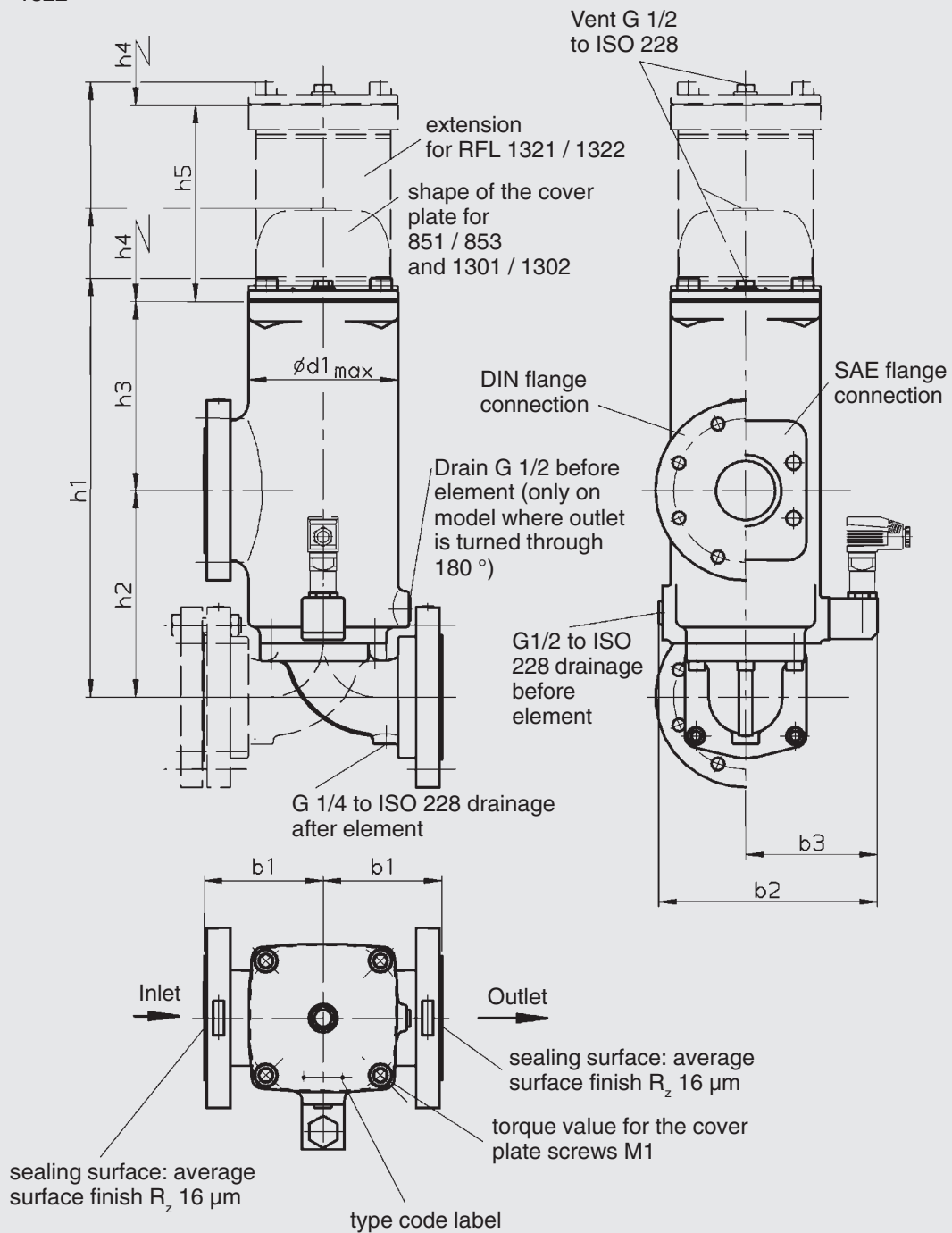

Type	Flange port	b1	b2	b3	d1	h1	h2	h3	h4	h5	M1 (Nm)
RFL 661/662	SAE DN 80	133	192	239	172	465	230	210	350	–	150
	DIN DN 80		184								
RFL 851 / 853	SAE DN 80	133	192	239	172	552	230	210	420	–	150
	DIN DN 80		184								
RFL 951/952	SAE DN 100	143	223	267	220	523	250	238	380	–	250
	DIN DN 100		215								
RFL 1301/1302	SAE DN 100	143	223	267	220	630	250	238	500	–	250
	DIN DN 100		215								
RFL 1321/1322	SAE DN 100	143	223	267	220	1084	250	238	940	561	250
	DIN DN 100		215								

7. NOTE

The information in this brochure relates to the operating conditions and applications described.
For applications or operating conditions not described, please contact the relevant technical department.
Subject to technical modifications.