

HYDAC

INTERNATIONAL

Pressure Filter For Sandwich Stacking DFZ

Flow rates up to 60 l/min

Pressure range up to 315 bar

Material: Steel

The pressure filters DFZ are designed for mounting between CETOP 3 and 5 valves. They can be fitted directly onto the units without any piping.



1. TECHNICAL SPECIFICATIONS

1.1 FILTER HOUSING

Construction

The filter housings are designed in accordance with international regulations. The filters consist of a filter head with a screw-on filter bowl.

Standard equipment:

- Service access on the right
- Without clogging indicator

1.2 FILTER ELEMENTS

HYDAC filter elements are tested according to the following ISO requirements:

- ISO 3724 Verification of flow fatigue characteristics
- ISO 4572 Contamination retention capacity
- ISO 4572 Multi-pass method for evaluating filtration performance
- ISO 3968 Evaluation of pressure drop versus flow characteristics
- ISO 2942 Bubble point test
- ISO 2941 Verification of collapse/burst resistance

Reliable filter operation is only guaranteed with original Hydac filter elements!

The filter elements are also suitable for use in dynamic applications due to their high pressure stability; max. permissible Δp across the element:

Betamicon®(BH3HC): 210 bar
Stainless steel fibre (V): 210 bar

Compatibility with operating fluids DIN ISO 2943:

- Hydraulic oils H to HLPD to DIN 51524
- Lubrication oils DIN 51517, APJ, ACEA, DIN 51515, ISO 6743
- Compressor oils DIN 51506
- Rapidly biodegradable operating fluids VDMA 24568 HETG, HEES, HEPG
- Non-flam operating fluids HFC and HFD
- Operating fluids with high water content (>50% water content) on request

For further details on filter elements:

Brochure no.: 7.200../..

1.3 CLOGGING INDICATORS

VD 8 C 0 /-V

Type of indicator _____
VD differential pressure measurement

Pressure setting _____
8 8 bar standard, others on request

Indicator type _____
BM = visual
C = electrical
D = visual/electrical

Modification number _____
0 the latest version is always supplied

Supplementary details _____
-V Viton
-LED 2 light emitting diodes up to 24 volt
-L.. Light with corresponding voltage (24, 48, 110, 220 Volt)
-W indicator suitable for oil-water emulsion (HFA, HFC)

For further details and other types of clogging indicator, please see **brochure no.: 7.050../..**

1.4 SEALS

Perbunan (= NBR) or Viton (= FPM) with HFD-oils (optional)

1.5 SPECIAL MODELS AND ACCESSORIES

– on request

1.6 SPARE PARTS

See Original Spare Parts List and Maintenance Instructions.

2. GENERAL

Mounting

As pressure filter for sandwich stacking

Temperature range

-10 °C to +100 °C

Other temperature ranges on request!

Pressure setting of the clogging indicator

$\Delta p_a = 8 \text{ bar} \pm 10\%$

Other pressure settings on request

Hydraulic symbol

Size 30

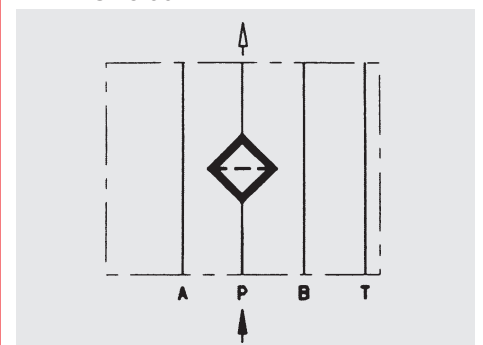

Hydraulic symbol

Size 60 / 110

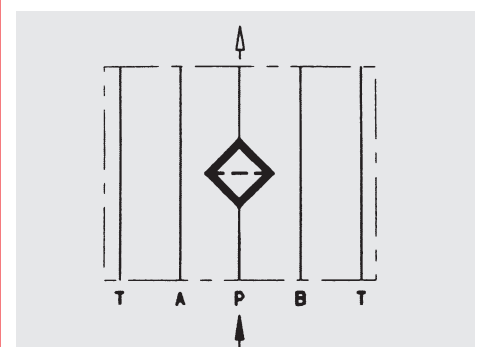

3. MODEL CODE (also order example)

DFZ BH/HC 60 Q B 10 D 1 . X /-L24

3.1. COMPLETE FILTER

Filter type _____

DFZ

Filter material of element _____

BH/HC Betamicron® (BH3HC)

V Stainless steel fibre

Housing material/size _____

Steel: 30, 60, 110

Operating pressure _____

Q = 315 bar (all sizes)

Type / Size of port _____

Type	Port	Filter size		
		30	60	110
B	4 ports A 6 DIN 24340/ Cetop R 35 H	●		
C	5 ports A 10 DIN 24340/ Cetop R 35 H		●	●

Filtration rating in µm _____

BH3HC, V : 3, 5, 10, 20

Type of clogging indicator _____

A without clogging indicator, steel blanking plug in indicator plug

BM with visual clogging indicator

C with electrical clogging indicator

D with visual and electrical clogging indicator

for further clogging indicators
see brochure no. 7.050../..

Type code _____

1

Modification number _____

X the latest version is always supplied

Supplementary details _____

V FPM seals, filter suitable for rapidly biodegradable oils and phosphate ester HFD-R

W NBR seals, filter suitable for oil-water emulsions (HFA, HFC) (only with V elements)

L... Light with appropriate voltage (24V, 48V, 110V, 220V)

LED 2 light emitting diodes up to 24 volt

1 service access left

only for clogging indicator
type D

3.2. REPLACEMENT ELEMENT

0060 D 010 BH3HC /-V

Size _____

0030, 0060, 0110

Type _____

D

Filtration rating in µm _____

3, 5, 10, 20

Filter material _____

BH3HC, V

Supplementary details _____

V = FPM seals, filter suitable for rapidly biodegradable oils and phosphate ester (HFD-R)

W = NBR seals, filter suitable for oil-water emulsions (HFA, HFC) (only with V elements)

4. FILTER SPECIFICATIONS

Filter type	Element size	Number of elements	Weight [kg] with element
30	0030 D...	1	2.4
60	0060 D...	1	5.9
110	0110 D...	1	6.8

5. FILTER CALCULATION / SIZING

The total pressure drop of a filter at a certain flow rate is the sum of the housing Δp and element Δp .

The pressure drop can be determined either with the aid of our Filter Sizing Program, which is available free of charge, or by using the following graphs.

It must be stressed that all of the technical documentation from Hydac Filtrertechnik always states the total housing pressure drop.

5.1. Δp -Q HOUSING GRAPHS BASED ON ISO 3968

The housing graphs apply to mineral oil with a density of 0.86 kg/dm^3 and a kinematic viscosity of $30 \text{ mm}^2/\text{s}$ for the largest possible width per size. In this case, the differential pressure changes proportionally to the density.

DFZ 30

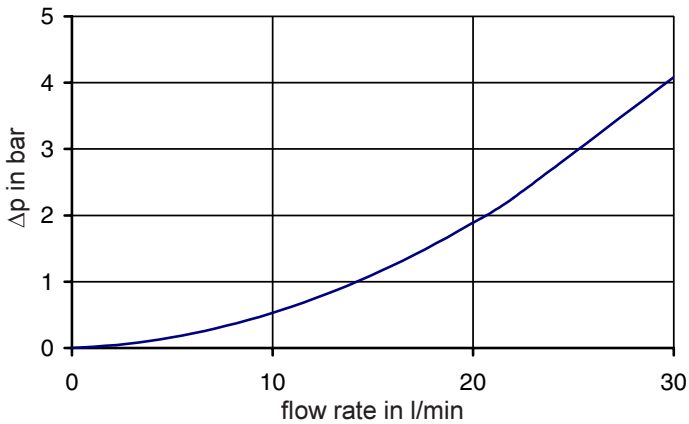

DFZ 60/110

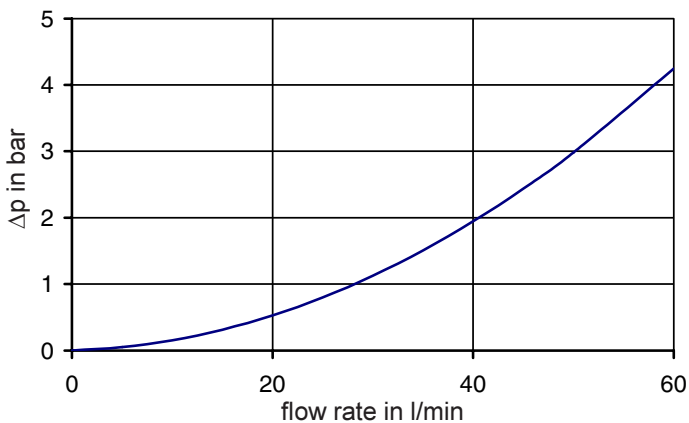

5.2. EXAMPLE

General

$$\Delta p_{\text{total}} = \Delta p_{\text{housing}} + \Delta p_{\text{element}} \times \frac{\text{Viscosity (mm}^2/\text{s)}}{30 \text{ mm}^2/\text{s}}$$

$$\Delta p_{\text{housing}} = \text{see point 5.1.}$$

$$\Delta p_{\text{element}} = \text{flow rate} \times \text{gradient coefficient (see 5.3)}$$

Example

System data:

Q = 40 l/min; DFZ 110 with BH3HC element (10 μm)

Viscosity = 46 mm²/s

$$\Rightarrow \Delta p_{\text{housing}} = 1.9 \text{ bar}$$

$$\Delta p_{\text{element}} = 0.35 \times \frac{46 \text{ mm}^2/\text{s}}{30 \text{ mm}^2/\text{s}} = 0.54 \text{ bar}$$

$$\Delta p_{\text{total}} = \Delta p_{\text{housing}} + \Delta p_{\text{element}} = \underline{\underline{2.44 \text{ bar}}}$$

5.3. Δp -Q-GRAPHS FILTER ELEMENTS

The element graphs apply to mineral oil with a kinematic viscosity of $30 \text{ mm}^2/\text{s}$. The pressure drop changes proportionally to the change in viscosity (see Example 5.2).

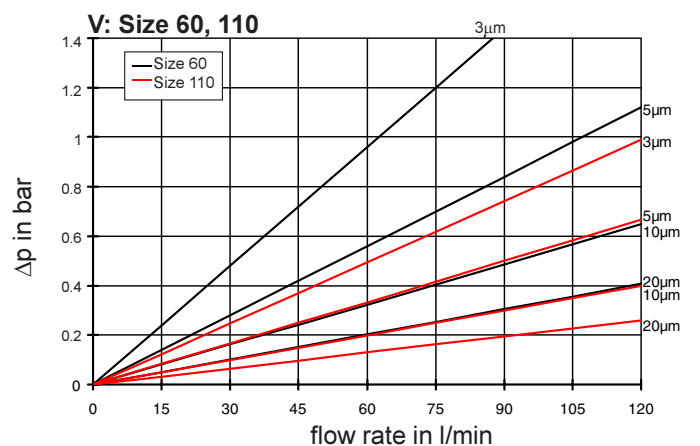
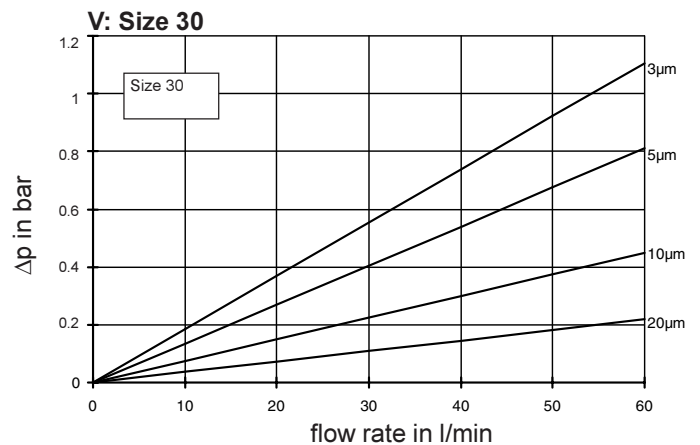
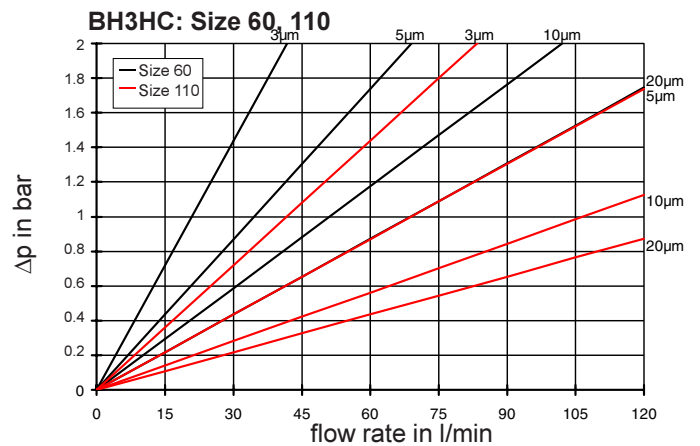
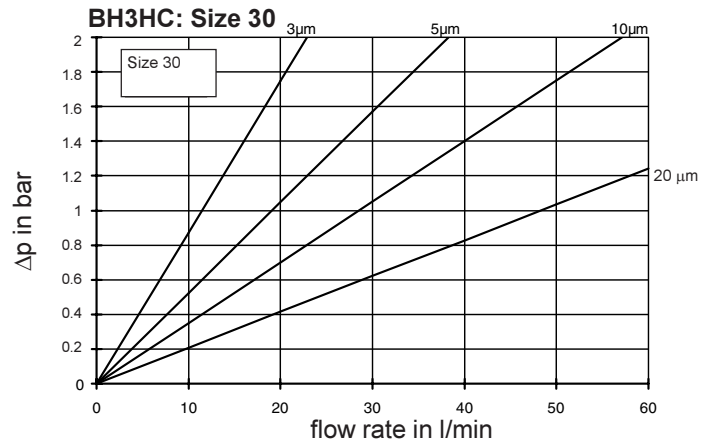

6. DIMENSIONS

6.1. DFZ 30

Shown with service access on right (Standard model)

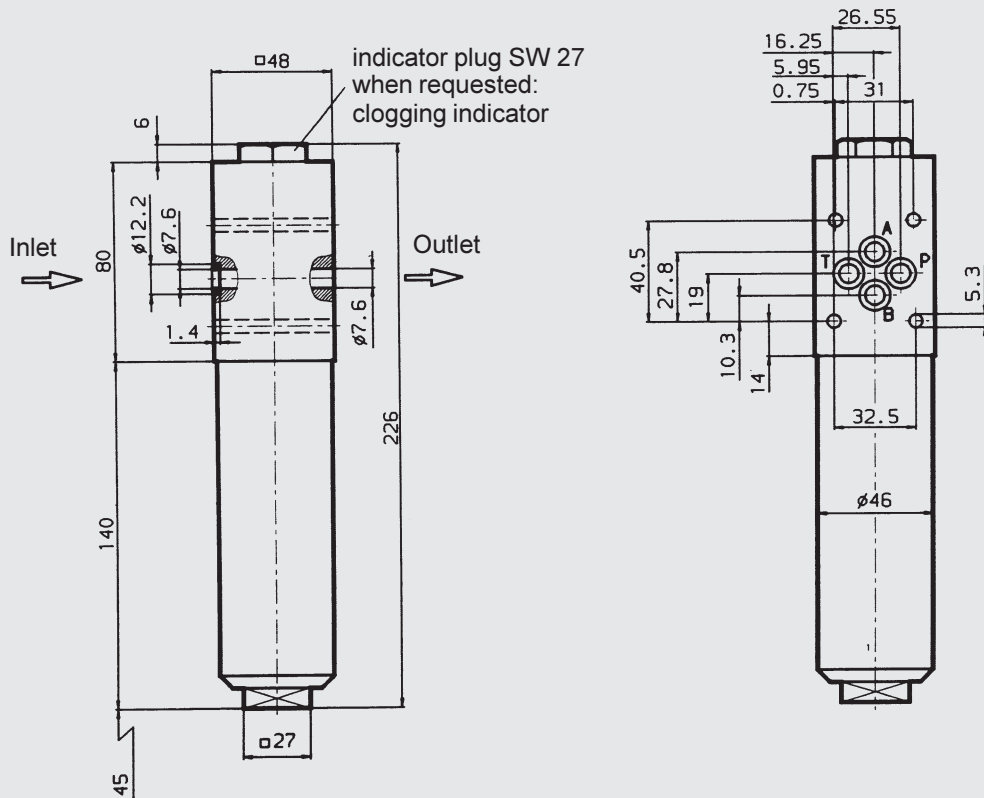

6.2. DFZ 60 / 110

Shown with service access on right (Standard model)

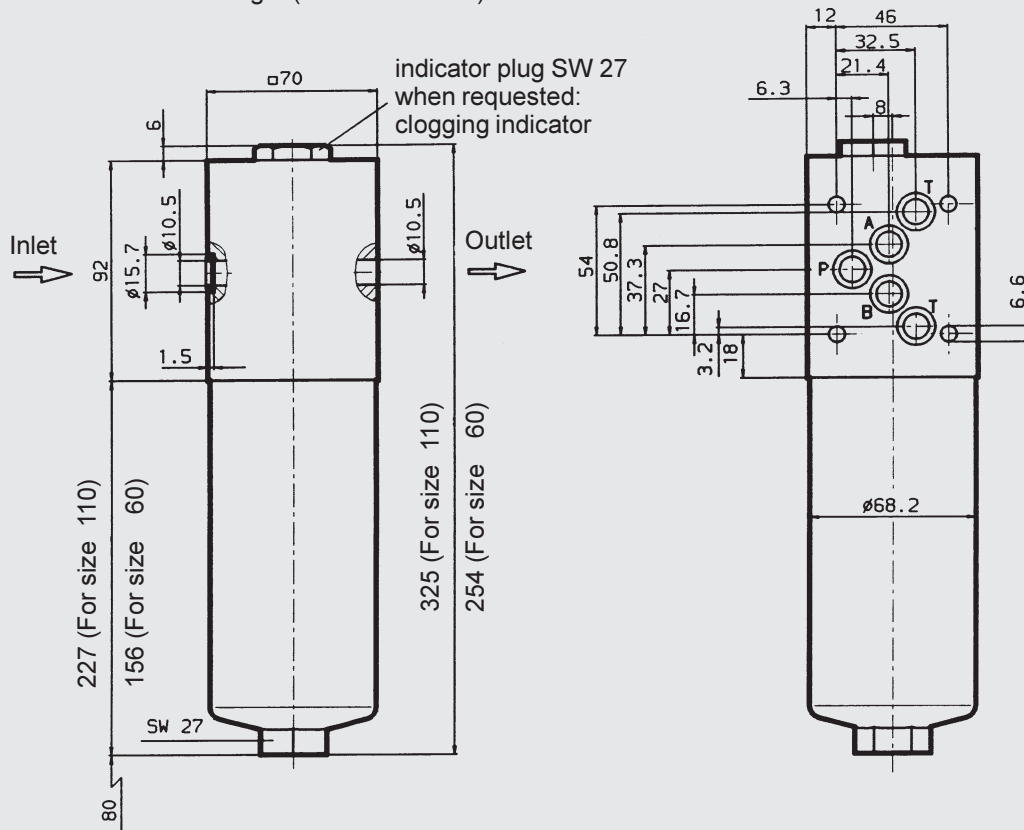

7. NOTE

The information in this brochure relates to the operating conditions and applications described. For applications or operating conditions not described, please contact the relevant technical department. Subject to technical modifications.