



Torqmotor™

Series TE / TJ

max 14 kW

aerospace
climate control
electromechanical
filtration
fluid & gas handling
hydraulics
pneumatics
process control
sealing & shielding



ENGINEERING YOUR SUCCESS.

DE Hinweis

Die in diesem Katalog oder in Form anderer Informationen durch die Parker Hannifin GmbH, ihre Niederlassungen, Vertriebsbüros oder ihre autorisierten Werksvertretungen gemachten Angaben sind für Anwender mit Sachkenntnissen bestimmt. Vom Anwender ist eine Überprüfung der über das ausgewählte Produkt gemachten Angaben auf Eignung für die geforderten Funktionen erforderlich. Bedingt durch die unterschiedlichen Aufgaben und Arbeitsabläufe in einem System muss der Anwender prüfen und sicherstellen, dass durch die Eigenschaften des Produkts alle Forderungen hinsichtlich Funktion und Sicherheit des Systems erfüllt werden.

UK Note

This document and other information from Parker Hannifin GmbH, its subsidiaries, sales offices and authorized distributors provide product or system options for further investigation by users having technical expertise. Before you select or use any product or system it is important that you analyse all aspects of your application and review the information concerning the product or system in the current product catalogue. Due to the variety of operating conditions and applications for these products or systems, the user, through his own analysis and testing, is solely responsible for making the final selection of the products and systems and assuring that all performance and safety requirements of the application are met. The products are subject to change by Parker Hannifin GmbH at any time without notice.

FR Note

Les indications données dans le présent catalogue ainsi que toutes autres informations fournies par Parker Hannifin GmbH, ses succursales, ses bureaux de vente ou ses représentations d'usine autorisées sont destinées aux utilisateurs ayant des connaissances techniques en la matière. L'utilisateur devra procéder à une vérification des indications faites sur le produit sélectionné pour savoir s'il est bien approprié aux fonctions demandées. Dû aux conditions environnementales variées dans les quelles ces composants et ces systèmes doivent opérer, l'utilisateur doit vérifier et s'assurer que les propriétés du produits répondent bien à toutes les exigences relatives au fonctionnement et à la sécurité du système.

IT Avvertenza

Le indicazioni fatte nel presente catalogo o sotto forma di altre informazioni dalla Parker Hannifin GmbH, dalle sue filiali, uffici di vendita o dalle sue consociate autorizzate, sono destinate a utenti con conoscenze tecniche. L'utente è tenuto a verificare che le indicazioni fatte sul prodotto scelto siano conformi alle funzioni richieste. A causa delle diverse applicazioni e condizioni d'impiego, l'utente deve verificare e assicurare che le proprietà del prodotto soddisfino tutte le esigenze relative al funzionamento e alla sicurezza del sistema.

Description DE	UK	FR	IT	Page
Merkmale	Features	Caractéristique	Prestazioni	4
Kenndaten	Performance	Puissance	Carratteristiche	5
Gehäuse	Housing	Carter	Scatola	6
Endanschluss	Rear Ports	Orifices arrières	Connessioni posteriori	8
Abtriebswelle	Coupling shaft	Arbre	Giunto	9
Anschlüsse	Ports	Orifices	Connessione	10
Diagramme	Diagrams	Diagrammes	Diagrammi	11
Beispiel	Example	Exemple	Esempio	13
Lebensdauer	Life Time	Durée	Durata	14
Bestellschlüssel	Ordering Code	Système de commande	Codice di ordinazione	15
Schockventil	Crossover relief valve	Valve antichoc	Valvola di soprapressione	17
Spülventil	Hot oil shuttle valve	Valve de rinçage	Valvola selettiva	18
Drehzahl-Sensor	Speed sensor	Compte-tours	Contagiri	19
Lamellenbremse	Multiple disc brake	Frein multi-disque	Freno multidisco	21
Betrieb	Operation	Mise en service	Istuzioni pez l' uso	22
Produktübersicht	Motor range	Gamme de moteurs	Gamma di motori	23

Features

- **Langsamlaufender Gerotor-Motor**
- **Spezielle Orbital-Steuerung**
Geringe interne Leckage
Hoher volumetrischer Wirkungsgrad
- **Rollen im Rotorsatz**
Reduzierte Reibung
Lange Lebensdauer
- **Patentierte Hochdruckwellendichtung**
Keine Leckölleitung
Keine Rückschlagventile
- **Vielzahl von Varianten**
Großer Einsatzbereich

Torqmotor
Series TE / TJ

- **Low Speed Gerotor Motor**
- **Zero leak commutation valve**
For greater, more consistent
Volumetric efficiency
- **Roller vane rotor set**
Reduces friction and internal leakage
Maintaining efficiency throughout the life of the motor
- **Patented high-pressure shaft seal**
No check valves needed
No extra plumbing
- **Wide choice of displacement range, flange and shaft options**
Greater efficiency in systems design
to suit your application

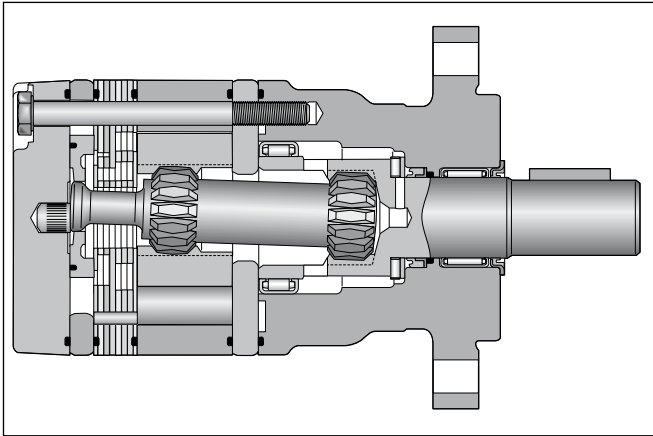
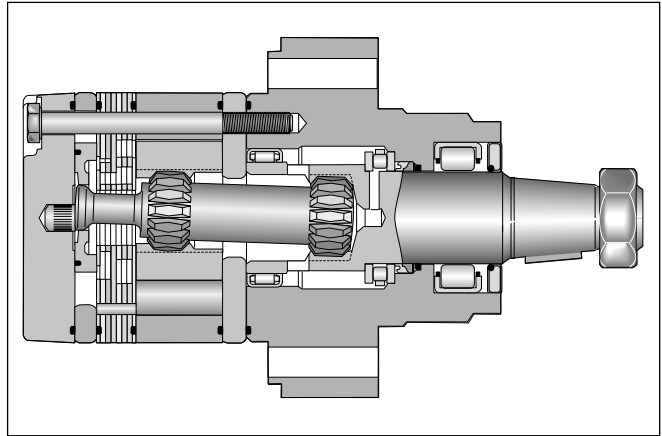
Series TE**Series TJ**

- **Moteur lent système Gerotor**
- **Une distribution orbitale particulière assure**
fuites internes minimales
rendements volumétriques élevés
- **Le rotor à rouleaux**
réduit les frottements
augmente la durée de vie
- **Par l'utilisation de joints d'arbre haute pression brevetés**
pas de conduite de drainage
pas de clapets anti-retour
- **Grâce à de nombreuses variantes**
larges domaines d'applications

- **Motore orbitale a bassa velocità**
- **Una particolare distribuzione orbitale assicura**
trafilamento ridotto elevato rendimento volumetrico
- **Con lo statore a rullo**
si riduce l'attrito interno
si mantiene nel tempo l'efficienza del motore
- **Una guarnizione di tenuta ad alta pressione brevettata elimina la necessità**
di una linea di drenaggio esterna e di valvole non ritorno
- **Un'ampia gamma di cilindrate, flangiature ed alberi**
consentono scelte adeguate ad ogni esigenza costruttiva

Performance

Drehzahl Speed Vitesse de rotation Velocità di rotazione	5...1160 rev/min
Schluckstrom Oil flow Débit d'huile Portata	max. 75 l/min
Eingangsdruck Supply pressure Pression entrée Pressione in entrata	max. 200 bar
Drehmoment Torque Couple Coppia	max. 550 Nm
Seitenlast Side load Charges latérales Carico radiale	TE = max. 7000 N TJ = max. 14000 N



Series TJ

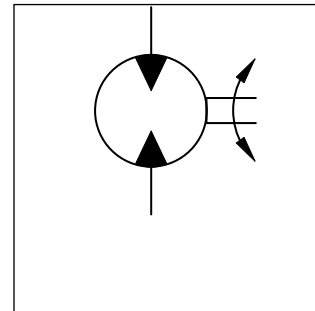

Series TE

Motor series TE / TJ	cm ³ /U cm ³ /rev	cont / int U/min rev/min	cont / int l/min	cont / int bar	max bar	cont / int Nm	cont / int KW	cont / int Nm
TE/TJ 36	36	930 / 1160	35 / 42	140 / 190	200	55 / 70	8,5	44 / 52
TE/TJ 45	41	810 / 990	35 / 42	140 / 190	200	70 / 100	10	44 / 64
TE/TJ 50	50	725 / 935	35 / 45	140 / 175	200	90 / 115	11	72 / 92
TE/TJ 65	66	705 / 940	45 / 60	140 / 175	200	125 / 160	15	100 / 128
TE/TJ 80	82	560 / 750	45 / 60	140 / 175	200	160 / 200	15	128 / 160
TE/TJ 100	98	470 / 630	45 / 60	140 / 175	200	190 / 240	15	152 / 192
TE/TJ 130	130	350 / 470	45 / 60	140 / 175	200	255 / 320	15	204 / 256
TE/TJ 165	163	280 / 375	45 / 60	140 / 175	200	310 / 395	15	248 / 316
TE/TJ 195	196	235 / 315	45 / 60	140 / 175	200	390 / 480	15	312 / 384
TE/TJ 230	228	265 / 330	60 / 75	120 / 150	200	380 / 480	15	304 / 384
TE/TJ 260	261	230 / 290	60 / 75	110 / 140	200	400 / 525	15	320 / 420
TE/TJ 295	293	200 / 255	60 / 75	100 / 130	200	410 / 520	13	328 / 416
TE/TJ 330	326	185 / 235	60 / 75	100 / 120	200	430 / 530	13	344 / 424
TE/TJ 365	370	150 / 200	60 / 75	95 / 110	200	467 / 558	11	373 / 446
TE/TJ 390	392	152 / 190	60 / 75	85 / 100	200	435 / 540	10	348 / 432

int. =

Intermittierende Werte maximal: 10% von jeder Betriebsminute.

Intermitt operation rating applies to 10% of every minute.

Fonctionnement interm.: 10% max. de chaque minute d'utilisation.

Servizio intermittente: 10% max di ogni minuto di utilizzazione.

Code C

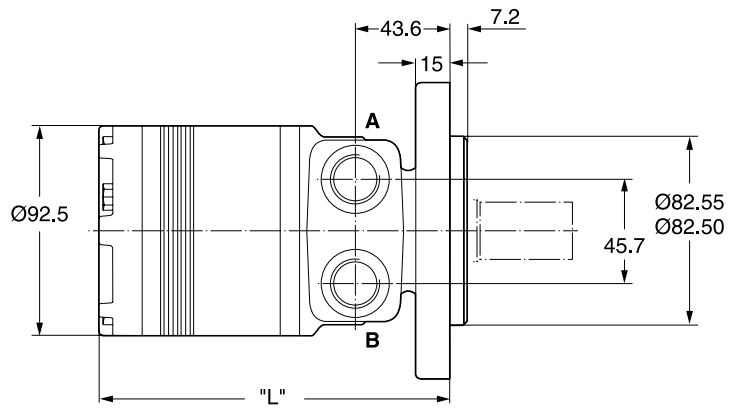
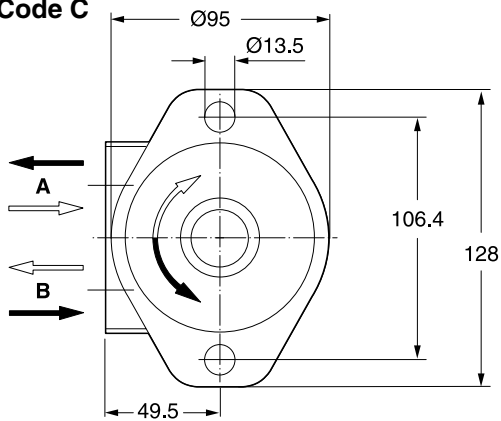

Code M

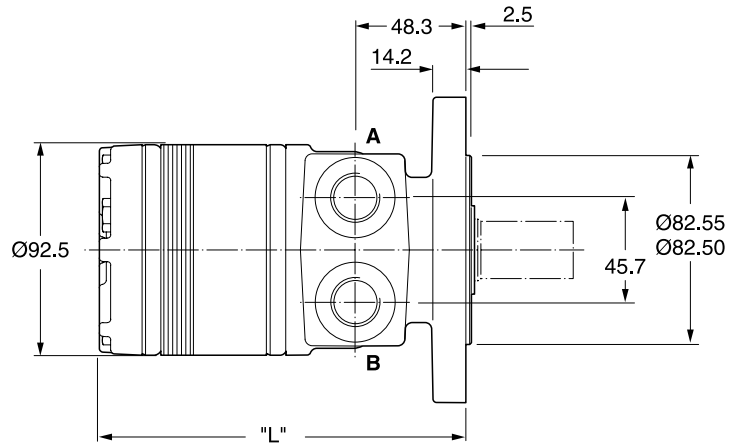
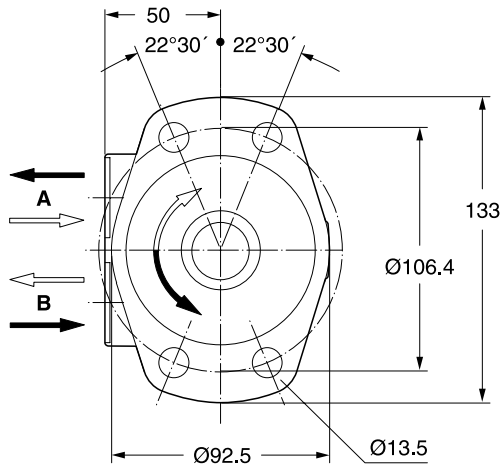

Code D

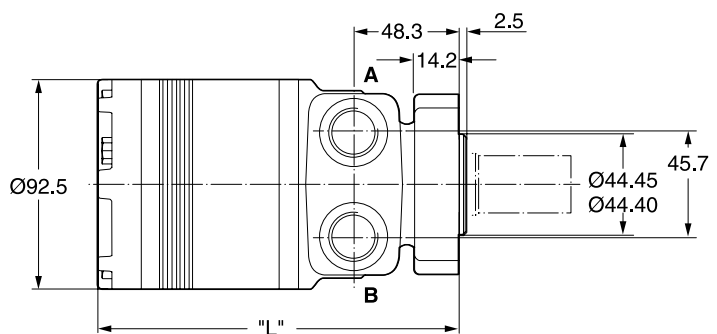
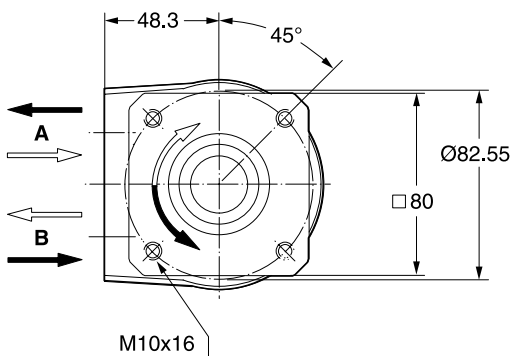

Gewicht / Weight	TE36	TE45	TE50	TE65	TE80	TE100	TE130	TE165	TE195	TE230	TE260	TE295	TE330	TE365	TE390
Poids / Peso [kg]	5.8	6.3	6.5	6.6	6.7	6.8	7.1	7.4	7.7	7.9	8.2	8.3	8.7	9.0	9.2
Code C "L" [mm]	128	131	133.1	136.1	139.5	142.5	148.8	155.2	161.5	167.9	174.2	180.6	186.9	195.1	199.9
Code M, D "L" [mm]	134	136	137.7	140.7	144	147	153.4	159.8	166.1	172.5	178.8	185.2	191.5	199.6	204.5

Code L

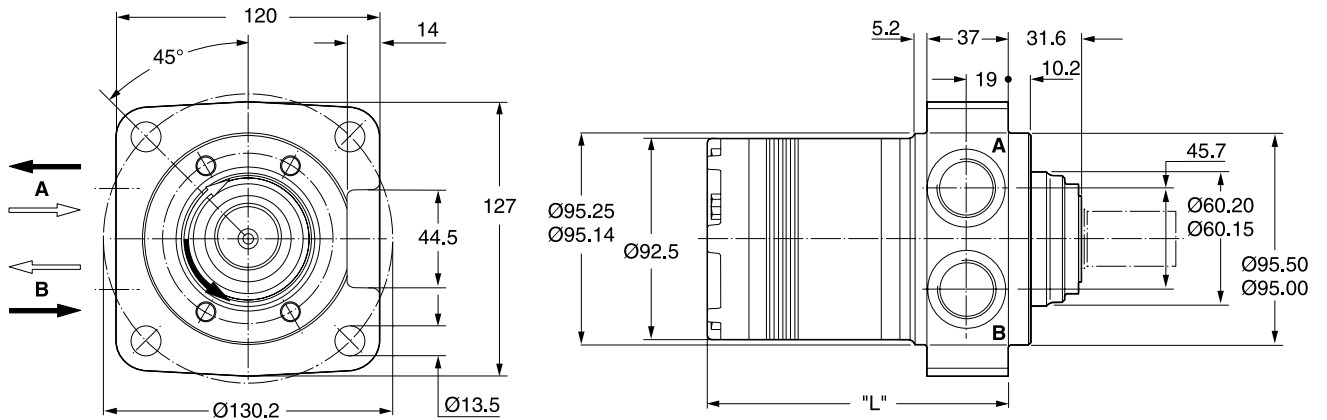

Code U

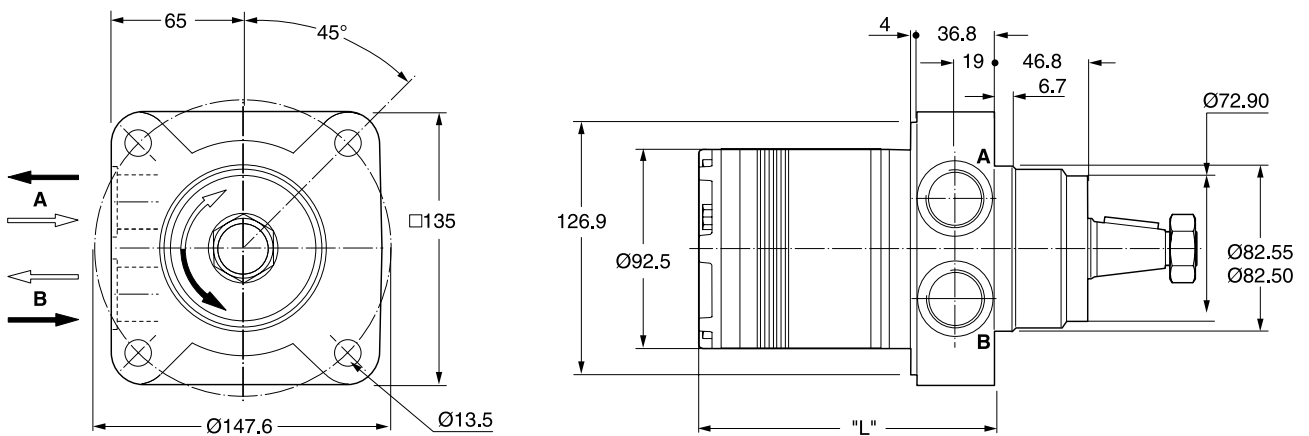

Gewicht / Weight	TJ36	TJ45	TJ50	TJ65	TJ80	TJ100	TJ130	TJ165	TJ195	TJ230	TJ260	TJ295	TJ330	TJ365	TJ390
Poids / Peso [kg]	6.7	6.8	6.9	7.0	7.1	7.2	7.6	7.8	8.1	8.3	8.6	8.8	9.1	9.4	9.6
Code L, U "L" [mm]	103	106	109	112	115	118	124	131	137	143	150	156	162	171	175

Code Y

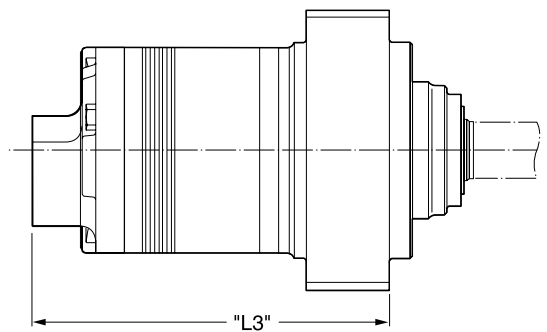
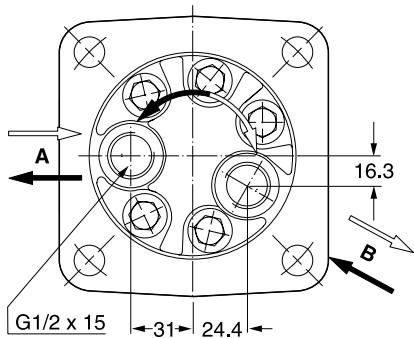
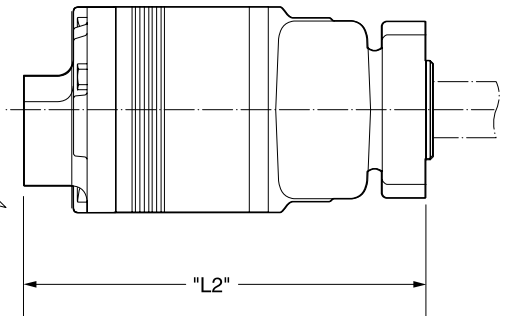
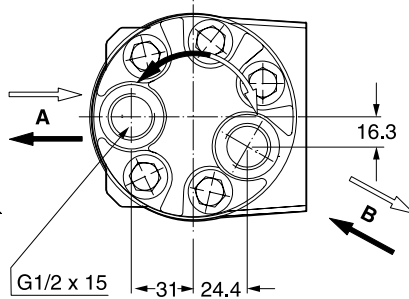
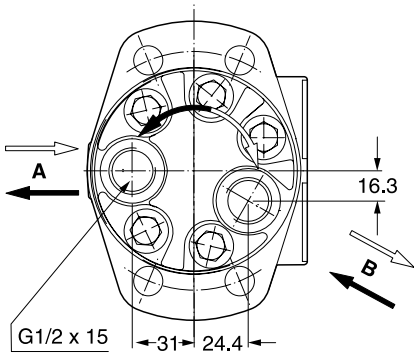
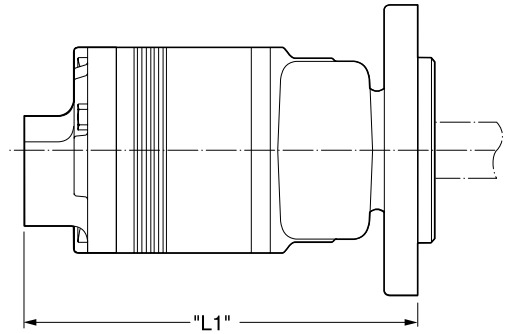
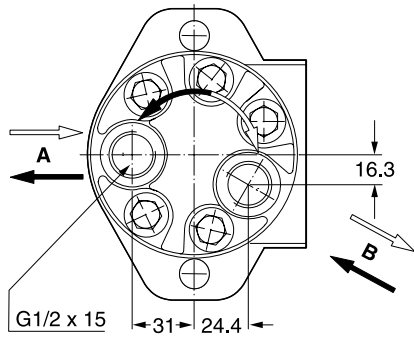

Gewicht / Weight	TE36	TE45	TE50	TE65	TE80	TE100	TE130	TE165	TE195	TE230	TE260	TE295	TE330	TE365	TE390	
Poids / Peso [kg]	7.2	7.3	7.4	7.5	7.6	7.7	8.1	8.3	8.6	8.8	9.1	9.3	9.6	9.9	10.1	
Code Y	"L1" [mm]	151	152	154	157	160	164	170	177	183	189	196	202	208	215.5	221
	"L2" [mm]	155	156	158	161	165	168	174	181	187	193	200	206	212	220	225
	"L3" [mm]	127	128	130	132	136	139	145	152	158	164	171	177	183	191.1	196

Code 08

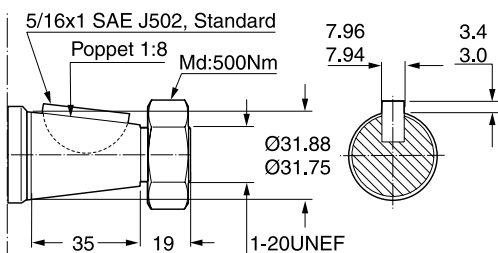

Code 10

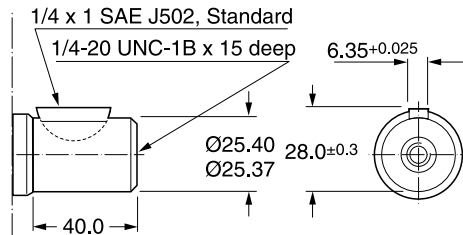

Code 12

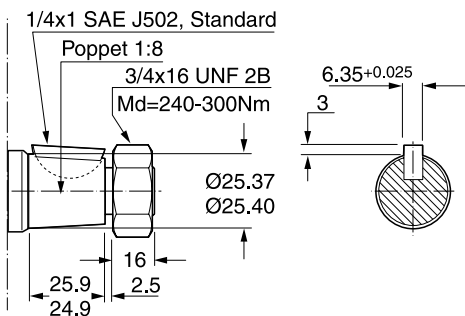

Code 25

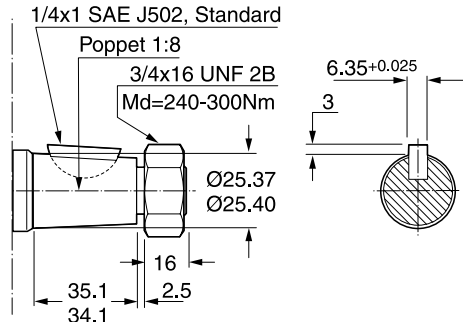

Code 26*

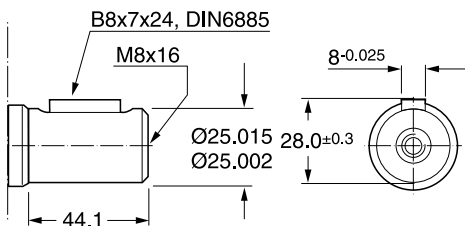

Code 41

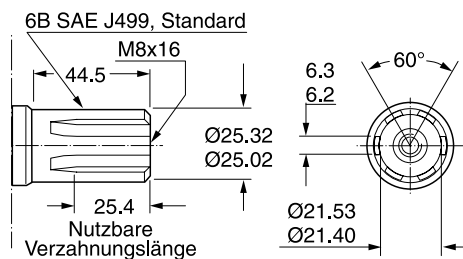

* **Code 69** = Rostfreie Ausführung / **Code 69** = Stainless steel version
Code 69 = Version en acier inoxydable / **Code 69** = Versione in acciaio inossidabile
 230 Nm (2100 lb in) Max. Drehmoment / Max Torque/ Couple maxi/ Coppia max

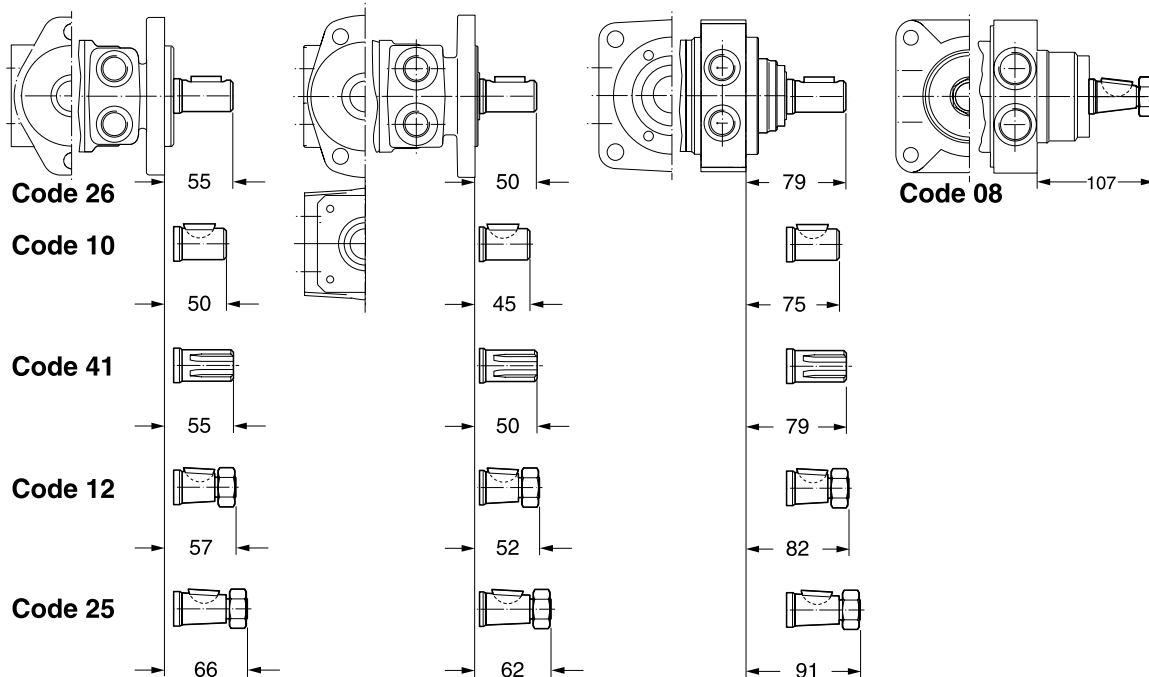

Code W

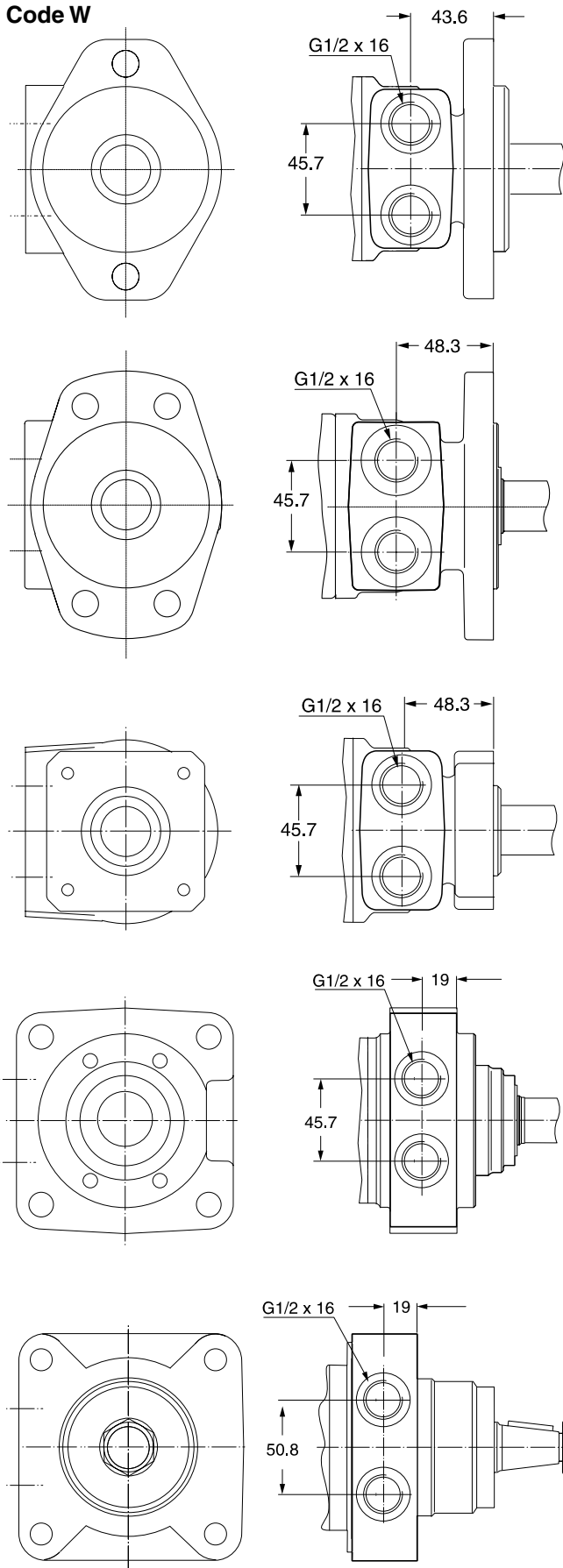

Code N

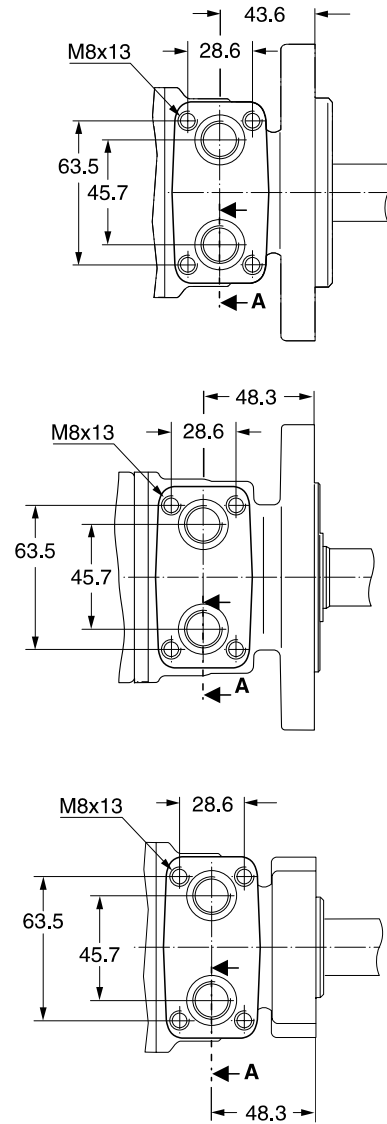

Section A

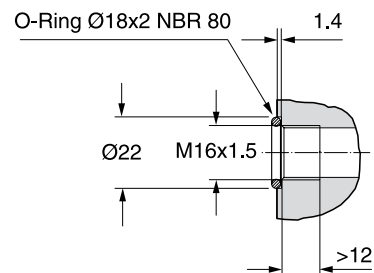

Zum Motor mit Universalanschluss werden 2 O-Ringe geliefert.

Motor with manifold mount is supplied with 2 O-rings.

Deux joints toriques sont livrés avec les moteurs au plan de raccordement universel.

Il blocchetto connessioni è corredato da 2 OR.

TE/TJ 36

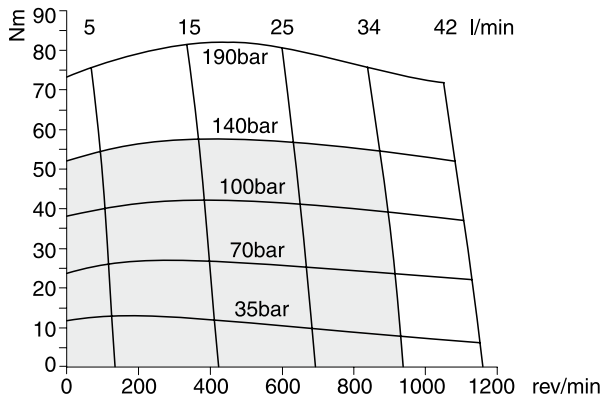

TE/TJ 45

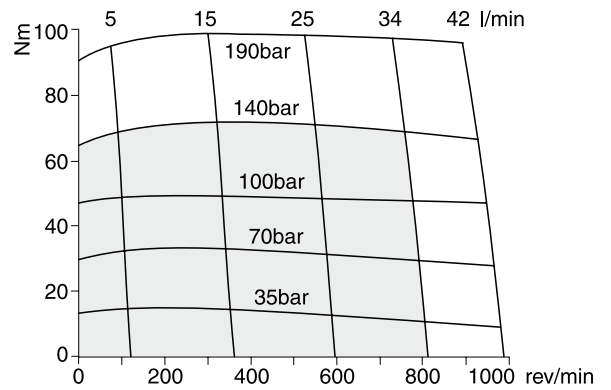

TE/TJ 50

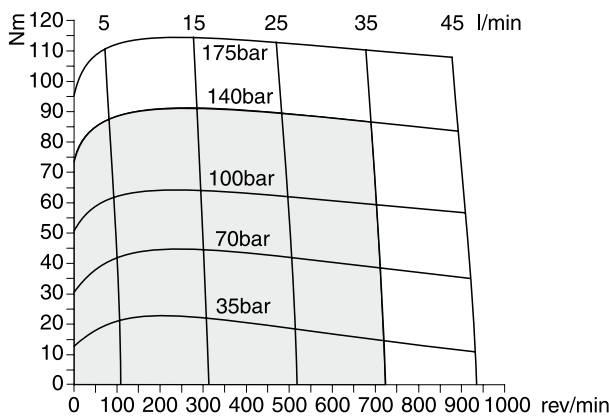

TE/TJ 65

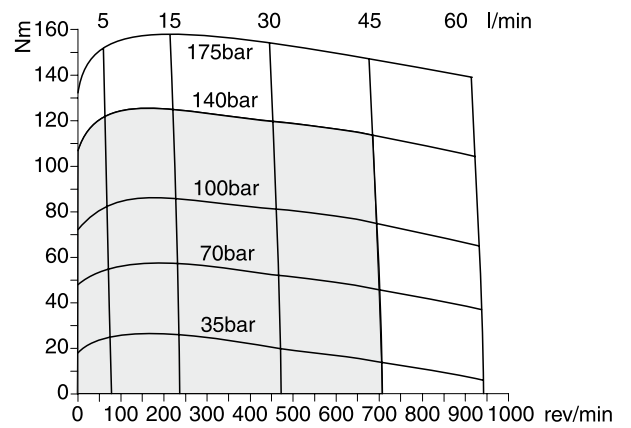

TE/TJ 80

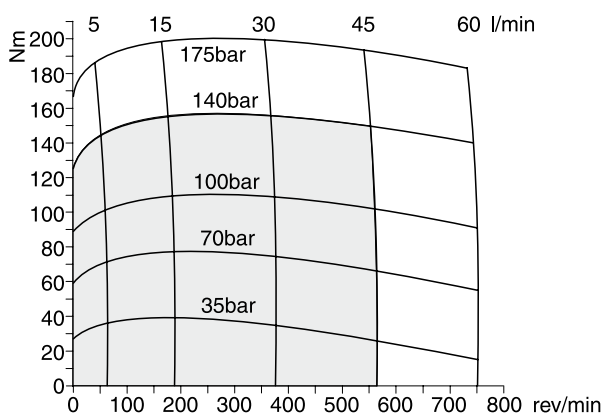

TE/TJ 100

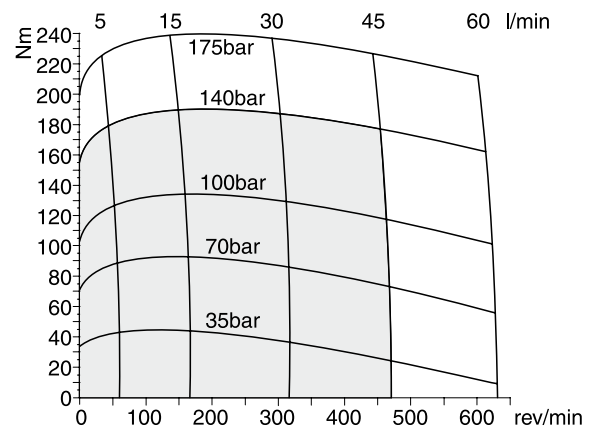

□ Cont.

□ Int.

int. =

Intermittierende Werte maximal 10% von jeder Betriebsminute.

Fonctionnement interm. 10% max. de chaque minute d'utilisation.

Intermittent operation rating applies to 10% of every minute.

Servizio intermittente 10% max di ogni minuto di utilizzazione.

TE/TJ 130

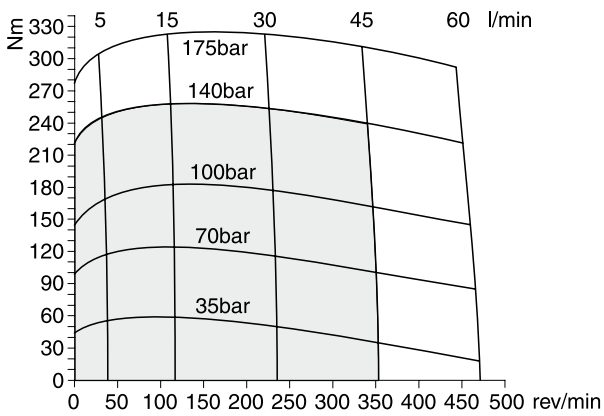

TE/TJ 165

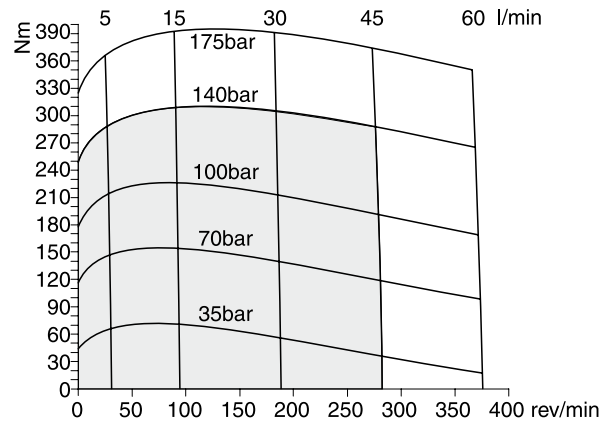

TE/TJ 195

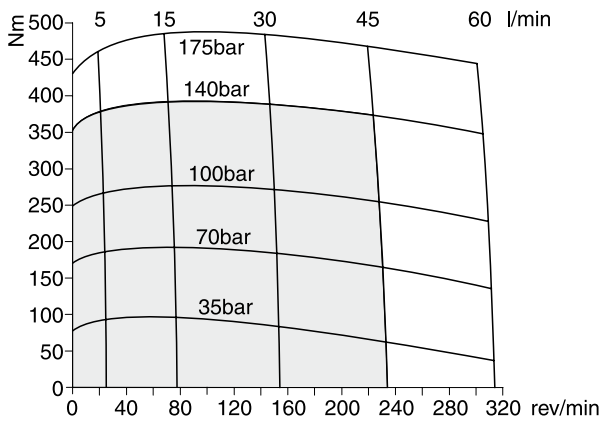

TE/TJ 230

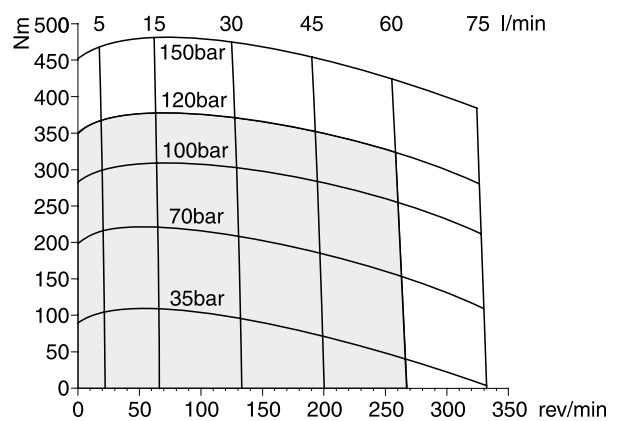

TE/TJ 260

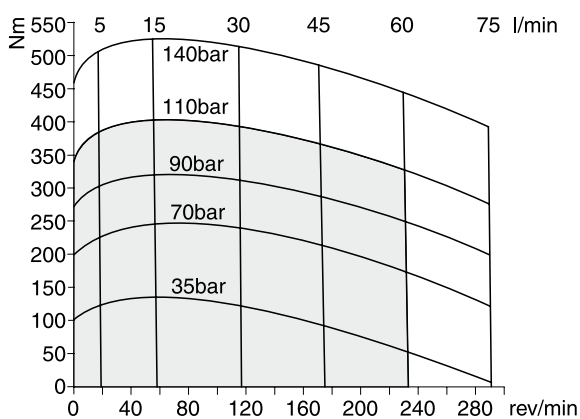

TE/TJ 295

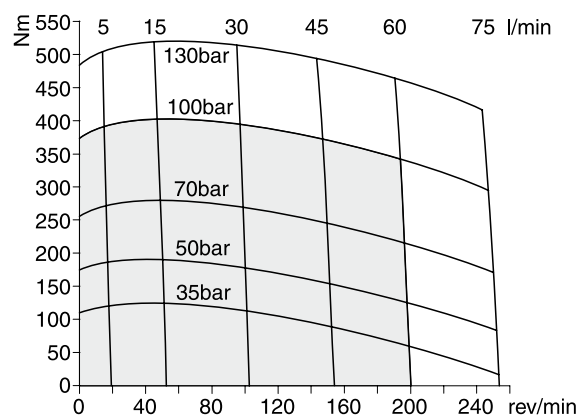

□ Cont.

□ Int.

int. =
 Intermittierende Werte maximal 10% von jeder Betriebsminute.
 Fonctionnement interm. 10% max. de chaque minute d'utilisation.
 Intermittent operation rating applies to 10% of every minute.
 Servizio intermittente 10% max di ogni minuto di utilizzazione.

TE/TJ 330

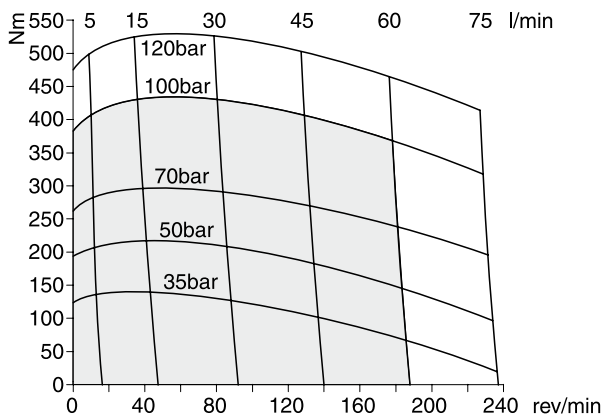

Beispiel / Example Series TE / TJ230

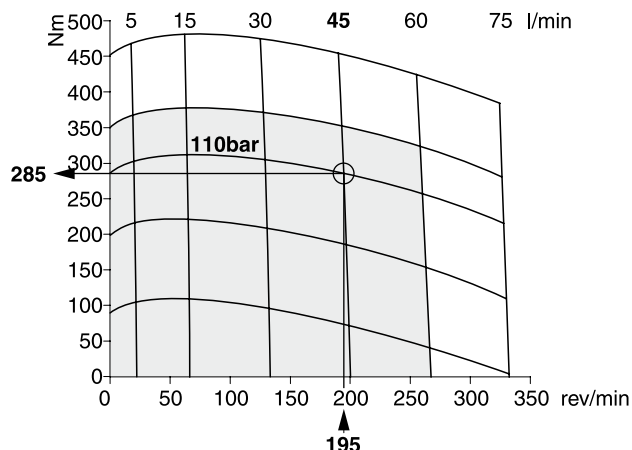

TE/TJ 365

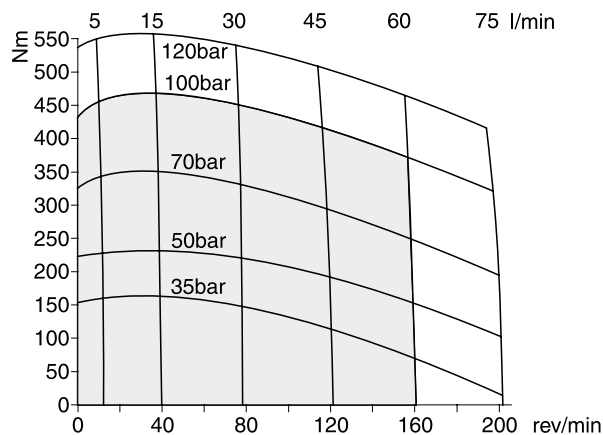

$M_d = 285 \text{ Nm}$ $V = 229.4 \text{ cm}^3/\text{rev}$
 $n = 195 \text{ rev/min}$ $Q = 45 \text{ l/min}$
 $\Delta p = 110 \text{ bar}$

Volumetrischer Wirkungsgrad (η_{vol})
 Volumetric efficiency
 Rendement volumétrique
 Rendimento volumetrico

$$\eta_{vol} = \frac{n \cdot V}{Q \cdot 10^3} = \frac{195 \cdot 229.4}{45 \cdot 10^3}$$

$\eta_{vol} = 0.99$

Hydraulisch-mechanischer Wirkungsgrad (η_{hm})
 Hydraulic-mechanical efficiency
 Rendement hydro-mécanique
 Rendimento idro-meccanico

$$\eta_{hm} = \frac{M_d \cdot 20 \cdot \pi}{\Delta p \cdot V} = \frac{285 \cdot 20 \cdot \pi}{110 \cdot 229.4}$$

$\eta_{hm} = 0.71$

Gesamtwirkungsgrad (η_{ges})
 Overall efficiency
 Rendement global
 Rendimento totale

$$\eta_{ges} = \eta_{vol} \cdot \eta_{hm} = 0.99 \cdot 0.71$$

$\eta_{ges} = 0.70$

TE/TJ 390

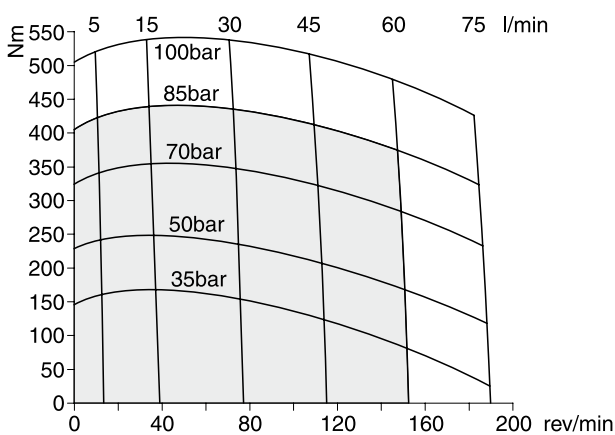

□ Cont. □ Int.

int. =
 Intermittierende Werte maximal 10% von jeder Betriebsminute.
 Fonctionnement interm. 10% max. de chaque minute d'utilisation.
 Intermittent operation rating applies to 10% of every minute.
 Servizio intermittente 10% max di ogni minuto di utilizzazione.

Leistung P (kW)
 Power P
 Puissance P
 Potenza P

$$P = \frac{M_d \cdot n \cdot \pi}{10^4 \cdot 3} = \frac{285 \cdot 195 \cdot \pi}{10^4 \cdot 3}$$

$P = 5.8 \text{ kW}$

TE Code C/D

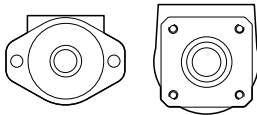

$$L_h = \frac{357300}{n \cdot \left(F_R \cdot \left(1.161 + \frac{L}{62\text{mm}} \right) \right)^{3.3}}$$

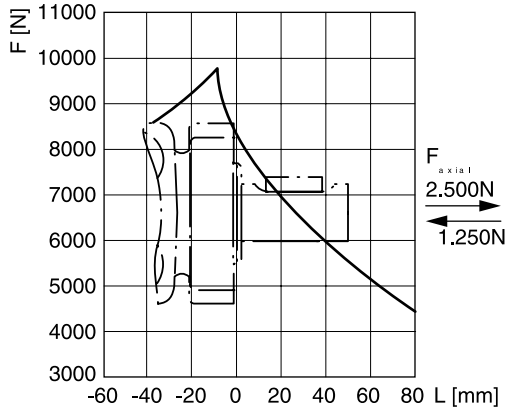

TE Code C

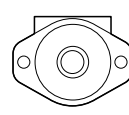

$$L_h = \frac{357300}{n \cdot \left(F_R \cdot \left(1.076 + \frac{L}{62\text{mm}} \right) \right)^{3.3}}$$

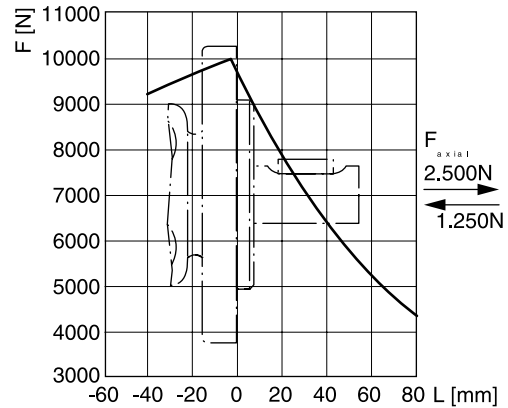

TE Code L

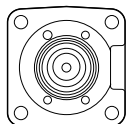

$$L_h = \frac{357300}{n \cdot \left(F_R \cdot \left(0.69 + \frac{L}{62\text{mm}} \right) \right)^{3.3}}$$

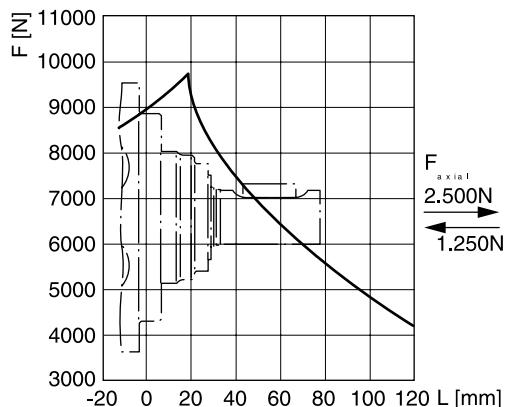

TJ Code U

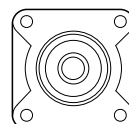

$$L_h = \frac{840000}{n \cdot \left(F_R \cdot \left(0.57 + \frac{L}{71\text{mm}} \right) \right)^{3.3}}$$

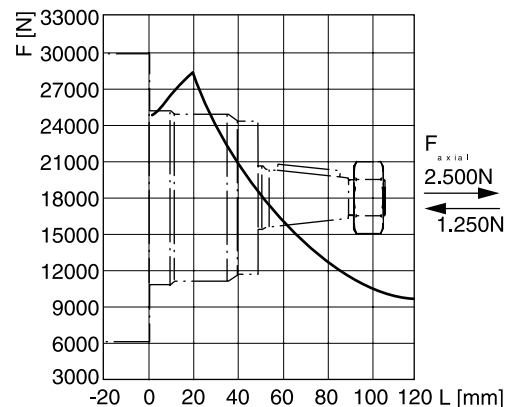

Die Lebensdauer der Radiallager (L_h in Stunden) lässt sich nach folgender Formel berechnen. Die Größe F_R ist durch die mechanische Festigkeit der Abtriebswelle begrenzt (siehe Diagramm). Das Maß "L" ist das Längenmaß vom Gehäuseflansch bis zum Angriffspunkt der Radialkraft F_R .

Life time (L_h in hours) of the radial bearings can be calculated with the following formula. The value F_R is limited by the mechanical strength of the shaft (see diagram). The measurement "L" is the length from the housing flange up to the point of impact of the radial force F_R .

La durée de vie des roulements radiaux (L_h en heures) peut être calculée par les formules suivantes. La grandeur F_R est limitée par les résistances mécaniques de l'arbre de sortie (voir diagramme). La cote "L" est la longueur entre la bride du carter jusqu'au point d'appui de l'effort radial F_R .



La durata dei cuscinetti (L_h in ore) può essere calcolata con la seguente formula. Il valore F_R è limitato dalla resistenza meccanica dell'albero (vedi diagramma). La quota "L" è la distanza tra la flangia del corpo ed il punto di applicazione della forza radiale F_R .

Vorstehende Formeln gelten für eine B10-Lebensdauer.
 The preceding formulas are valid for a B10 duration of life.
 Les formules précédentes sont valables pour une durée de vie B10.
 Le formule precedenti sono valide per una durata della vita B10.

L_h = h
 L = mm
 F_R = F (N)
 n = rev/min

TE	<input style="width: 100%;" type="text"/>	<input style="width: 100%;" type="text"/>	<input style="width: 100%;" type="text"/>	<input style="width: 100%;" type="text"/>	<input style="width: 100%;" type="text"/>	<input style="width: 100%;" type="text"/>	<input style="width: 100%;" type="text"/>
Series	Schluckvolumen Displacement Cylindrée Cilindrata	Gehäuse Housing Carter Scatola motore	Anschluss Ports Plan de raccordement Conessioni	Welle Shaft Arbre Albero	Drehrichtung Direction of rotation Direction de rotation Direzione di rotazione	Option	

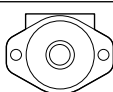
Code	cm ³ /rev
0036	36
0045	41
0050	50
0065	66
0080	82
0100	98
0130	130
0165	163
0195	196
0230	228
0260	261
0295	293
0330	326
0365	370
0390	392

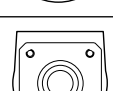
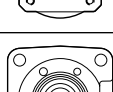



Code	Housing
C	
M	
D	
L	

Code	Port
W	G 1/2
N ¹⁾	universal port M8x13
Y	rear port G 1/2 axial

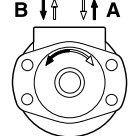
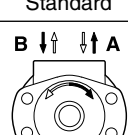
Code	Option
AAAB	standard
AANC	shuttle valve
BBCP ²⁾	internal relief valve 100 bar
BBCN ²⁾	internal relief valve 140 bar
HAAP	external relief valve 100 bar
HAAU	external relief valve 140 bar

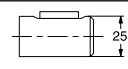
²⁾ Nicht verfügbar für Anschluss Y
 Not available for port code Y
 Pas disponible pour raccordement code Y
 Non Disponibile per connessioni codice Y

Code	Direction
0	 Standard
1	

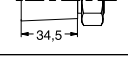
Code	Shaft
26 69 ³⁾	
10	
41	 6B SAE
12	
25	

³⁾ Code 69 =
 Rostfreie Ausführung
 Version en acier inoxydable
 Stainless steel version
 Versione in acciaio inossidabile

230 Nm (2100 lb in) Max Torque

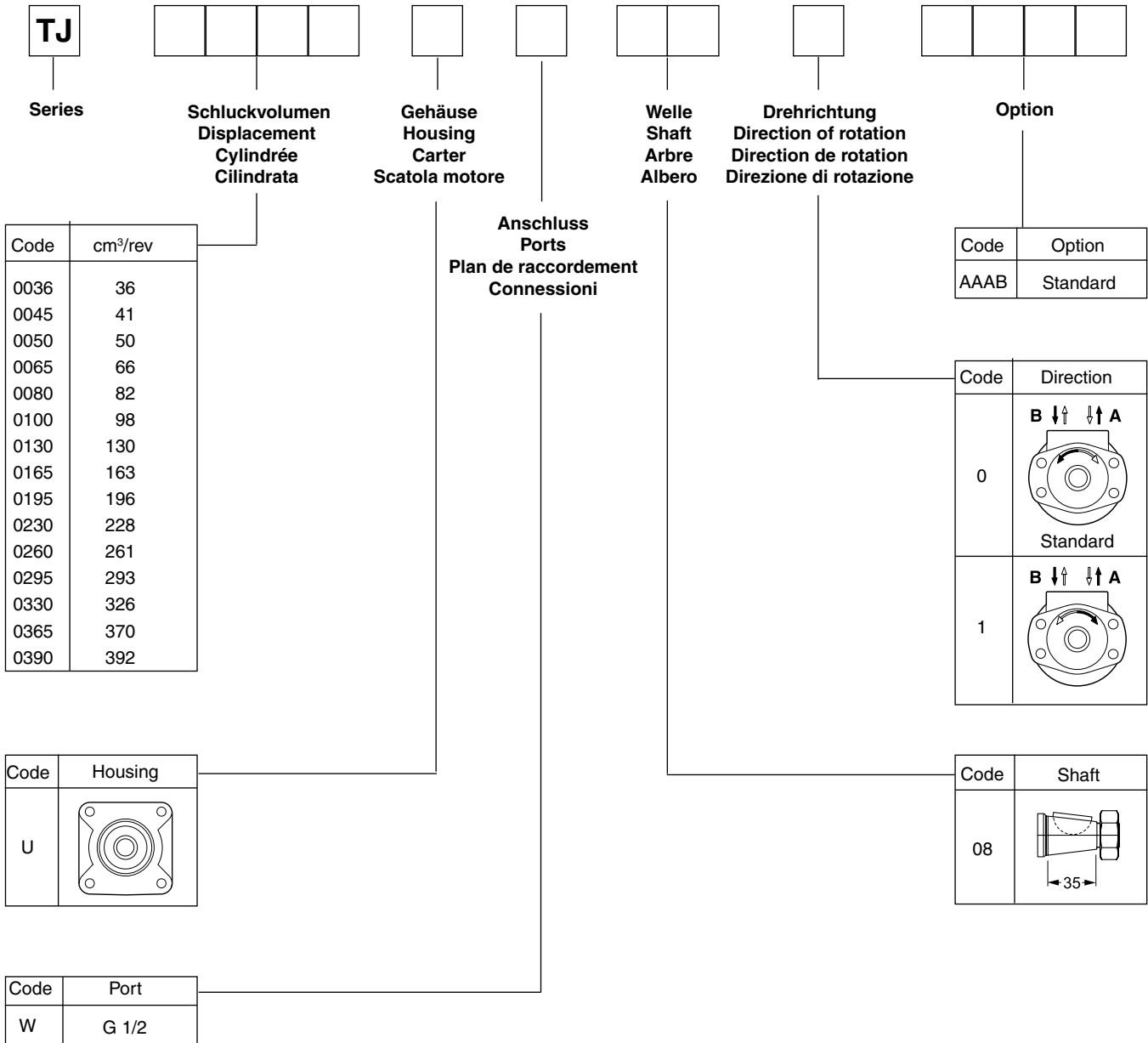

Schockventil / Relief valve / Soupape sécurité / Regolatrice pressione

Extern / external

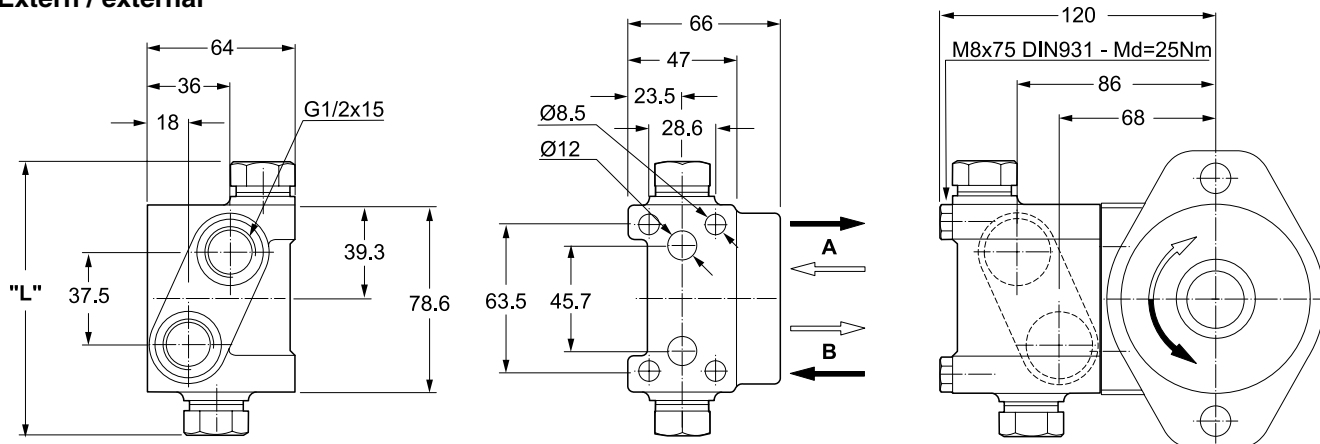

Bestellschlüssel / Ordering code / Système de commande / Sistema di ordinazione

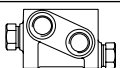
Option code	Shift pressure	Single valve	Single part order no.	Option code	Length "L"
HAAP	100 bar	 Zubehör / Fixtures 4 x M8 x 75mm 2 x O Ring	410017-100	HAAP	110 mm
HAAU	140 bar		410017-140	HAAU	158 mm

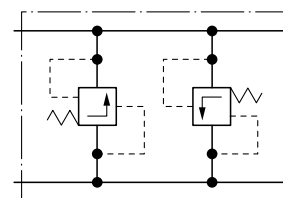

Intern / internal

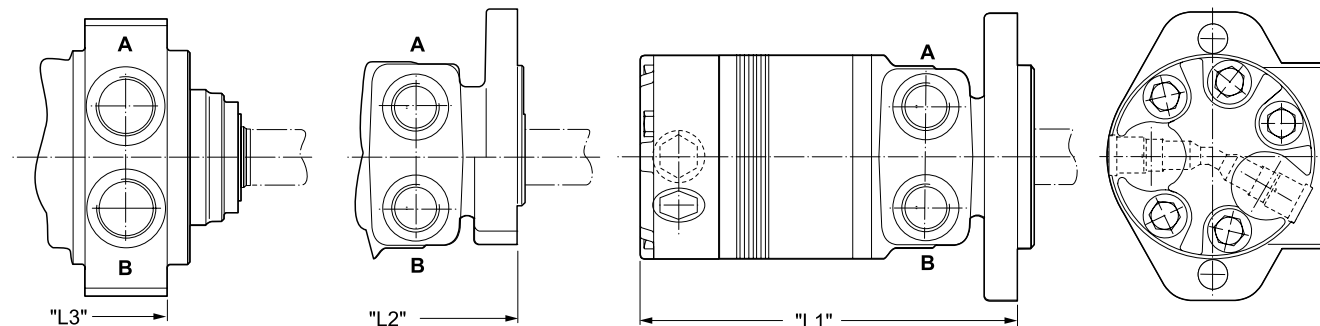

Bestellschlüssel / Ordering code / Système de commande / Sistema di ordinazione

Option code	Shift pressure
BBCP	100 bar
BBCN	140 bar

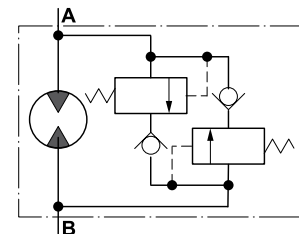

Gewicht / Weight	TE36	TE45	TE50	TE65	TE80	TE100	TE130	TE165	TE195	TE230	TE260	TE295	TE330	TE365	TE390
Poids / Peso [kg]	7.8	7.9	8.0	8.1	8.2	8.3	8.6	8.9	9.2	9.4	9.7	9.8	10.2	10.5	10.7
Code	"L1" [mm]	157	159.8	161.8	164.8	168.2	171.2	177.5	183.9	190.2	196.6	202.9	209.3	215.6	223.8
	"L2" [mm]	163	164.4	166.4	169.4	172.7	175.7	182.1	188.5	194.8	201.2	207.5	213.9	220.2	228.2
	"L3" [mm]	134	135.5	137.5	140.5	143.5	146.7	153.2	159.5	165.8	172.3	178.6	185.0	191.3	199.4

Code AANC

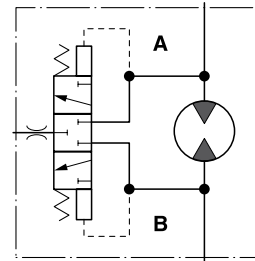
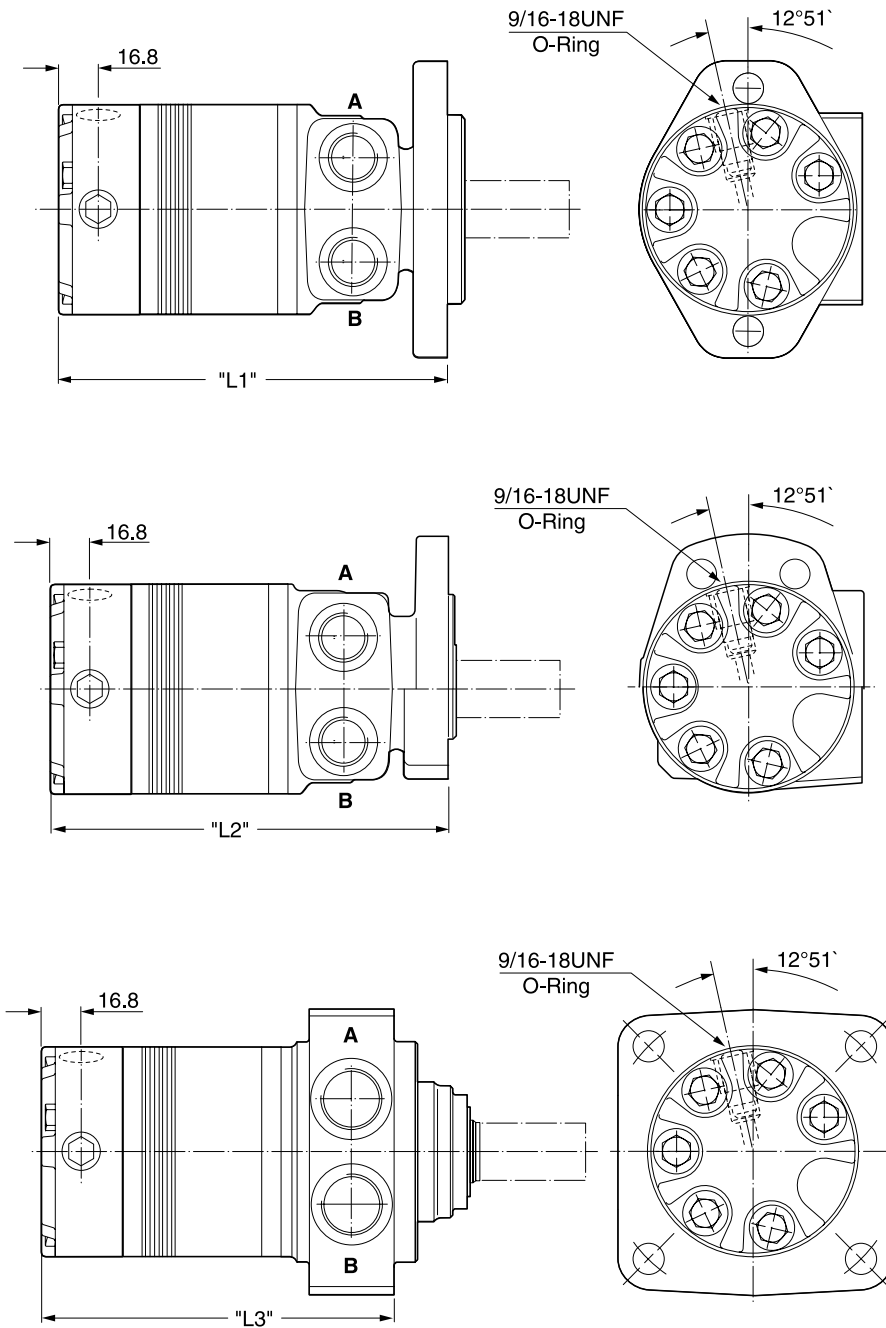

Q=5 l p=9 bar $\dot{v}=39 \text{ mm}^2/\text{s}$

Spülventil für geschlossene Systeme zur Rückführung einer definierten Menge des Niederdrucköls in den Tank zur Abkühlung innerhalb des Selben Kreislaufs.

Hot oil shuttle valve allows for diverting of low pressure oil in closed loop applications to be returned to tank, cooler or filter for cooling in the same circuit.

Valve de rinçage pour systèmes fermes pour le retour d'un volume déterminé de fluide basse pression vers le réservoir, un refroidisseur ou un filtre de réfrigération, dans le même circuit.

Una valvola scambiatrice di calore permette di deviare olio a bassa pressione direttamente al serbatoio o allo scambiatore de calore consentendo, nelle applicazioni a circuito chiuso, un miglior raffreddamento dell'olio.

Gewicht / Weight		TE36	TE45	TE50	TE65	TE80	TE100	TE130	TE165	TE195	TE230	TE260	TE295	TE330	TE365	TE390
Poids / Peso [kg]		7.4	7.5	7.6	7.7	7.8	7.9	8.3	8.5	8.8	9.0	9.3	9.5	9.8	10.0	10.3
Code	"L1" [mm]	149	150	152	155	158	161	168	174	180	187	193	199	206	214	219
	"L2" [mm]	153	154	156	159	162	166	172	178	184	191	197	203	210	218	222
	"L3" [mm]	124	125	127	130	134	137	143	150	156	162	168	175	181	189	194

Dieser robuste, wetterfeste Drehzahlaufnehmer arbeitet nach dem Halleffekt. Es werden 30 Rechteckimpulse pro Abtriebswellenumdrehung erzeugt. Durch Erfassung der positiven und negativen Wellenflanken sind 60 Impulse pro Umdrehung möglich. Der Sensor führt zu keiner Leistungsbeschränkung des Motors. Die volle Radiallastkapazität bleibt erhalten.

This rugged, weather resistant speed sensor is a Hall effect device. When externally powered, 30 square wave digital pulses per output shaft revolution are produced. By signal multiplication, 60 pulses per revolution can be obtained. The installation of this economical sensor does not affect the torque or side load capability of the motor into which it is installed.

Un capteur économique pour mesure de la vitesse. Ce capteur robuste et résistant aux intempéries est a effet Hall. Alimenté par une source externe, il fournit 30 impulsions carrées par tour. Par multiplication électronique, on obtient 60 impulsions par tour. Son montage ne modifie pas le couple ni la charge radiale du moteur qui le reçoit.

Sensore di velocità ad effetto Hall, estremamente robusto e resistente alle intemperie. Genera 30 impulsi al giro, con uscita digitale ad onda quadra. Il numero di impulsi può essere elettronicamente raddoppiato. L'utilizzo di questo sensore, non influisce sulle caratteristiche di coppia o di potenza del motore idraulico.

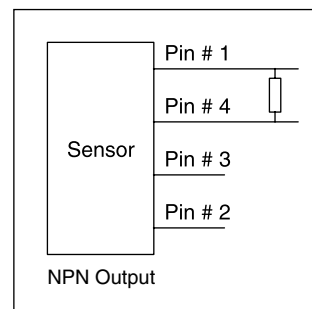
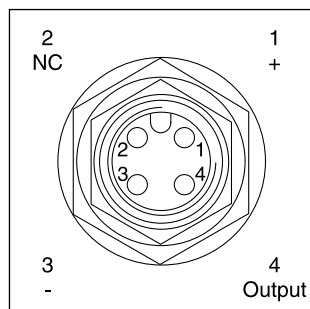

Versorgungsspannung Operating voltage range Courant d'alimentation Tensione di alimentazione	4.5...24 V (DC)
Arbeitstemperatur Operating temperature Température Temperatura di funzionamento	-30°...100° C
Arbeitsfrequenz Operating frequency range Fréquence d'utilisation Frequenza di lavoro	0...10 KHZ
Erforderlicher Laststrom Sink current Courant depeau Corrente di alimentazione	0...20 mA (max.)
Anschluss Connection Raccordement Connessione elettrica	4 Pin (12mm) DIN Standard

Formel Pullup-Widerstand Formula pull-up resistor value Formule valeur pull-up resistor Calcolo resistenza di carico	(0.25 Watt, Tol. 5%) (0.25 Watt, 5% tol.) (0.25 Watt, tol. 5%) (0.25 Watt, toll. 5%)	Spannung/Voltage Courant/Tensione	4.5...24 V	=	Widerstand Resistor Résistance Resistenze	k Ohm
		Laststrom/Sink current Courant/Corrente	0...20 mA			
		Status: aus/State: off Courant: off/Condizione: off (95% +V)			Status: ein/State: on Courant: on/Condizione: on (max. 0.4 V DC)	
		+ V				
		0 V				

Option FSAB

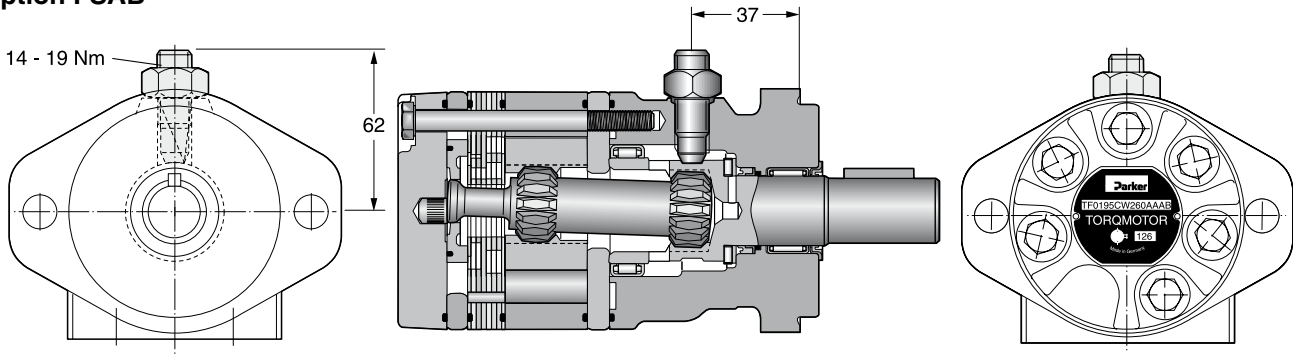

Der Sensor ist gegen Verpolung der Versorgungsspannung, jedoch nicht gegen Kurzschluss geschützt.

Le capteur est protégé contre l'inversion de polarité de la tension d'alimentation, mais pas contre les courts circuits.

The sensor has reverse polarity protection but no short circuit protection.

Il sensore è protetto contro l'inversione della polarità della tensione di alimentazione, ma non contro il corto circuito.

Ordering code

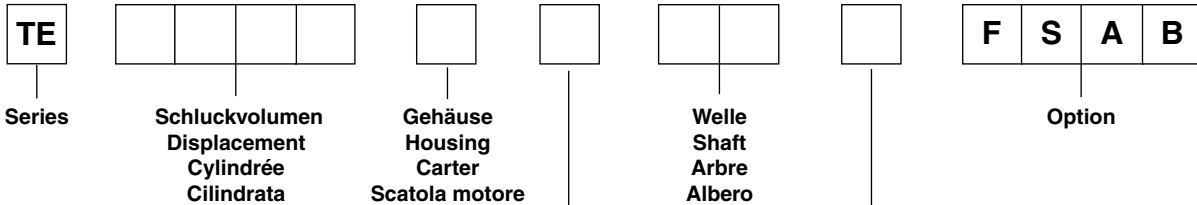

Anschluss Ports Plan de raccordement Conessioni		Drehrichtung Direction of rotation Direction de rotation Direzione di rotazione	
Code	cm ³ /rev	Code	Direction
0036	36	0	B ↓ ↑ A Standard
0045	41	1	B ↓ ↑ A
0050	50		
0065	66		
0080	82		
0100	98		
0130	130		
0165	163		
0195	196		
0230	228		
0260	261		
0295	293		
0330	326		
0365	370		
0390	392		
Code	Housing	Code	Shaft
C		26	
		10	
		41	
Code	Port		
W	G 1/2		
N	universal port M8x13		
Y	rear port G 1/2 axial		

Empfohlen wird die Verwendung eines Hydrauliköls auf Mineralölbasis mit mindestens 0,1% Zinkadditiv als Anti-verschleißzusatz. Vor Einsatz anderer Flüssigkeiten bitten wir um Rücksprache mit unserer Technik.

Die normale Arbeitstemperatur sollte im Bereich von +30 °C bis +60 °C liegen. Die Maximaltemperatur darf +90 °C nicht überschreiten, während die Mindesttemperatur auf -30 °C begrenzt ist.

Wird die normale Arbeitstemperatur wesentlich überschritten, wird die Lebensdauer des Öls stark verkürzt. Die Viskosität im Arbeitstemperaturbereich sollte 20 bis 120 mm²/s betragen.

Zweckmäßig ist eine Filtereinheit von 20-50 µm.

Die im Katalog angegebenen technischen Daten gelten für den Motorbetrieb.

Arbeitet der Motor als Pumpe, ist das auf die Antriebswelle wirkende Moment auf den angegebenen kontinuierlichen Maximalwert zu begrenzen. Dabei muss ein Vorspanndruck von 5-10 bar, abhängig vom Förderstrom, vorhanden sein (Kavitationsgefahr).

It is recommended to use a mineral based hydraulic oil with minimum 0.1% of zinc as anti-wear additive.

Before using other liquids, please consult our engineering department.

Normal working temperatures should be in the range of between +30 °C and +60 °C. Maximum temperatures must not exceed +90 °C while minimum temperatures should be limited to -30 °C.

If normal working temperatures are substantially exceeded this will result in reduced life duration of the oil used.

Viscosity in the range of working temperatures should be 20 to 120 mm²/s.

It is advisable to use a filtering fineness of 20-50 µm.

The technical data are applicable to motor operation. If the motor is used as a pump, the input torque on the coupling shaft must be limited to the indicated continuous maximum value. For this, an inlet pressure of 5-10 bar must be applied depending on oil flow (danger of cavitation).

Il est recommandé d'utiliser une huile hydraulique à base minérale contenant au minimum 0,1% d'additif zinc comme produit anti-usure.

La température normale d'utilisation devrait être située entre +30 °C à +60 °C.

La température maximale d'utilisation ne doit pas être supérieure à +90 °C, alors que la température minimale est limitée à -30 °C.

Lorsque la température de service est largement dépassée, la durée de vie de l'huile est fortement diminuée.

Dans la plage de température de service, la viscosité devrait être située entre 20 et 120 mm²/s.

Dans ce but, la filtration est de 20 à 50 µm.

Les caractéristiques techniques indiquées dans le catalogue sont considérées pour une utilisation en fonction moteur.

Si le moteur fonctionne en pompe, il faut limiter le couple à la valeur maximale indiquée. Dans ce cas, en fonction du débit, il faut créer une contre-pression de 5 à 10 bar (danger de cavitation).

Come elemento antiusura aggiuntivo si consiglia l'impiego di olio idraulico a base di olio minerale con almeno 0,1% di additivo allo zinco. Prima dell'impiego di altri liquidi si prega di contattare il nostro ufficio tecnico.

La temperatura normale di esercizio dovrebbe essere da +30 °C a +60 °C.

La temperatura massima non deve superare +90 °C, mentre la temperatura minima è limitata a -30 °C.

Se la temperatura normale di esercizio viene sostanzialmente superata, la durata dell'olio diminuisce sensibilmente.

La viscosità nel campo della temperatura di esercizio dovrebbe essere da 20 a 120 mm²/s.

Si deve prevedere un sistema filtrante per 20...50 µm.

I dati sopraesposti sono validi negli impieghi come motore. Se il motore viene usato come pompa, la coppia sull'albero deve essere limitata a quella massima ammessa. Pertanto il motore deve essere pressurizzato da 5...10 bar in funzione della portata d'olio per evitare cavitazione.

Produktübersicht Motor range Gamme de moteurs Serie di motori	Geom. Schluckvolumen Cylindric displacement Cilindrata	Max. Drehzahl Max. speed Vitesse de rotation maxi Velocità di rotazione maxi	Max. Schluckstrom Max. oil flow Debit d'huile maxi Portata max	Max. Druckdifferenz Max. differential pressure Chute de pression maxi Caduta di pressione max	Max. Eingangsdruck Max. supply pressure Pression maxi entrée Pressione max in entrata	Max. Drehmoment Max. torque Couple maxi Coppia max	Max. Leistungabgabe Max. performance Pulsance de sortie maxi Potenza meccanica max	
TE / TJ	cm³/rev	rev/min	cont / int l/min	cont / int bar	bar	cont / int Nm	max KW	
TE/TJ36	36	930 / 1160	35 / 42	140 / 190	200	55 / 70	8.5	Radiale Wellenbelastung Side loads Charges latérales Carico radiale TE 7.000 N TJ 14.000 N
TE/TJ45	41	810 / 990	35 / 42	140 / 190	200	70 / 100	10	
TE/TJ50	50	725 / 935	35 / 45	140 / 175	200	90 / 115	11	
TE/TJ65	66	705 / 940	45 / 60	140 / 175	200	125 / 160	15	
TE/TJ80	82	560 / 750	45 / 60	140 / 175	200	160 / 200	15	
TE/TJ100	98	470 / 630	45 / 60	140 / 175	200	190 / 240	15	
TE/TJ130	130	350 / 470	45 / 60	140 / 175	200	255 / 320	15	
TE/TJ165	163	280 / 375	45 / 60	140 / 175	200	310 / 395	15	
TE/TJ195	196	235 / 315	45 / 60	140 / 175	200	390 / 480	15	
TE/TJ230	228	265 / 330	60 / 75	120 / 150	200	380 / 480	15	
TE/TJ260	261	230 / 290	60 / 75	110 / 140	200	400 / 525	15	
TE/TJ295	293	200 / 255	60 / 75	100 / 130	200	410 / 520	13	
TE/TJ330	326	185 / 235	60 / 75	100 / 120	200	430 / 530	13	
TE/TJ365	370	150 / 200	60 / 75	95 / 110	200	467 / 558	11	
TE/TJ390	392	152 / 190	60 / 75	85 / 100	200	435 / 540	10	
TF	cm³/rev	rev/min	cont / int l/min	cont / int bar	bar	cont / int Nm	max KW	
TF 80	81	550/730	45/60	200/280	300	215/295	19	Radiale Wellenbelastung Side loads Charges latérales Carico radiale TF 16.000 N
TF 100	100	600/750	60/75	160/240	300	210/315	21	
TF 130	128	470/580	60/75	140/200	300	240/350	19	
TF 140	141	370/530	60/75	140/200	300	250/390	18	
TF 170	169	355/440	60/75	140/200	300	330/485	19	
TF 195	197	300/380	60/75	140/200	300	380/560	19	
TF 240	238	320/420	75/100	140/200	300	460/685	24	
TF 280	280	270/350	75/100	140/200	300	550/800	24	
TF 360	364	200/260	75/100	130/200	300	590/910	24	
TF 405	405	170/230	75/100	130/175	300	650/910	21	
TF 475	477	150/200	75/100	115/140	300	680/850	17	
TG/BG TH	cm³/rev	rev/min	cont / int l/min	cont / int bar	bar	cont / int Nm	max KW	
TG/BG, TH 140	140	530/710	75/100	200/280	300	400/ 545	33	Radiale Wellenbelastung Side loads Charges latérales Carico radiale TG/BG 16.000 N TH 30.000 N
TG/BG, TH 170	169	440/575	75/100	200/280	300	485/ 670	33	
TG/BG, TH 195	195	380/510	75/100	200/280	300	560/ 770	33	
TG/BG, TH 240	237	320/420	75/100	200/280	300	685/ 945	32	
TG/BG, TH 280	280	270/350	75/100	200/280	300	800/1100	31	
TG/BG, TH 335	337	225/290	75/100	200/280	300	980/1350	30	
TG/BG, TH 405	405	185/245	75/100	170/240	300	960/1350	27	
TG/BG, TH 475	476	160/240	75/115	140/200	300	960/1400	28	
TG/BG, TH 530	529	140/215	75/115	140/170	300	1050/1280	23	
TG/BG, TH 625	624	120/185	75/115	120/160	300	1040/1360	20	
TG/BG, TH 785	786	95/145	75/115	100/140	300	1150/1490	17	
TG/BG, TH 960	958	78/119	75/115	70/100	300	925/1390	12	
TK	cm³/rev	rev/min	cont / int l/min	cont / int bar	bar	cont / int Nm	max KW	
TK 250	251	520	114 / 133	240 / 310	330	815 / 1040	49	Radiale Wellenbelastung Side loads Charges latérales Carico radiale TK 26.000 N
TK 315	315	410	114 / 133	240 / 310	330	1030 / 1315	47	
TK 400	400	370	114 / 151	205 / 275	290	1150 / 1525	49	
TK 500	500	300	114 / 151	205 / 275	290	1440 / 1915	48	
TK 630	629	240	114 / 151	205 / 225	240	1620 / 1715	34	
TK 800	800	275	151 / 227	190 / 205	240	1915 / 2300	44	
TK 1000	1000	220	151 / 227	175 / 190	220	2410 / 2660	35	

int. = Intermittierende Werte maximal: 10% von jeder Betriebsminute.
Intermittent operation rating applies to 10% of every minute.

Fonctionnement interm.: 10% max. de chaque minute d'utilisation.
Servizio intermittente: 10% max di ogni minuto di utilizzazione.

Parker Worldwide

AE – UAE, Dubai
Tel: +971 4 8875600
parker.me@parker.com

AR – Argentina, Buenos Aires
Tel: +54 3327 44 4129

AT – Austria, Wiener Neustadt
Tel: +43 (0)2622 23501-0
parker.austria@parker.com

AT – Eastern Europe, Wiener Neustadt
Tel: +43 (0)2622 23501 970
parker.easteurope@parker.com

AU – Australia, Castle Hill
Tel: +61 (0)2-9634 7777

AZ – Azerbaijan, Baku
Tel: +994 50 2233 458
parker.azerbaijan@parker.com

BE/LX – Belgium, Nivelles
Tel: +32 (0)67 280 900
parker.belgium@parker.com

BR – Brazil, Cachoeirinha RS
Tel: +55 51 3470 9144

BY – Belarus, Minsk
Tel: +375 17 209 9399
parker.belarus@parker.com

CA – Canada, Milton, Ontario
Tel: +1 905 693 3000

CH – Switzerland, Etoy
Tel: +41 (0) 21 821 02 30
parker.switzerland@parker.com

CN – China, Shanghai
Tel: +86 21 5031 2525

CZ – Czech Republic, Klecany
Tel: +420 284 083 111
parker.czechrepublic@parker.com

DE – Germany, Kaarst
Tel: +49 (0)2131 4016 0
parker.germany@parker.com

DK – Denmark, Ballerup
Tel: +45 43 56 04 00
parker.denmark@parker.com

ES – Spain, Madrid
Tel: +34 902 33 00 01
parker.spain@parker.com

FI – Finland, Vantaa
Tel: +358 (0)20 753 2500
parker.finland@parker.com

FR – France, Contamine s/Arve
Tel: +33 (0)4 50 25 80 25
parker.france@parker.com

GR – Greece, Athens
Tel: +30 210 933 6450
parker.greece@parker.com

HK – Hong Kong
Tel: +852 2428 8008

HU – Hungary, Budapest
Tel: +36 1 220 4155
parker.hungary@parker.com

IE – Ireland, Dublin
Tel: +353 (0)1 466 6370
parker.ireland@parker.com

IN – India, Mumbai
Tel: +91 22 6513 7081-85

IT – Italy, Corsico (MI)
Tel: +39 02 45 19 21
parker.italy@parker.com

JP – Japan, Fujisawa
Tel: +(81) 4 6635 3050

KR – South Korea, Seoul
Tel: +82 2 559 0400

KZ – Kazakhstan, Almaty
Tel: +7 7272 505 800
parker.easteurope@parker.com

LV – Latvia, Riga
Tel: +371 6 745 2601
parker.latvia@parker.com

MX – Mexico, Apodaca
Tel: +52 81 8156 6000

MY – Malaysia, Subang Jaya
Tel: +60 3 5638 1476

NL – The Netherlands, Oldenzaal
Tel: +31 (0)541 585 000
parker.nl@parker.com

NO – Norway, Ski
Tel: +47 64 91 10 00
parker.norway@parker.com

NZ – New Zealand, Mt Wellington
Tel: +64 9 574 1744

PL – Poland, Warsaw
Tel: +48 (0)22 573 24 00
parker.poland@parker.com

PT – Portugal, Leca da Palmeira
Tel: +351 22 999 7360
parker.portugal@parker.com

RO – Romania, Bucharest
Tel: +40 21 252 1382
parker.romania@parker.com

RU – Russia, Moscow
Tel: +7 495 645-2156
parker.russia@parker.com

SE – Sweden, Spånga
Tel: +46 (0)8 59 79 50 00
parker.sweden@parker.com

SG – Singapore
Tel: +65 6887 6300

SK – Slovakia, Banská Bystrica
Tel: +421 484 162 252
parker.slovakia@parker.com

SL – Slovenia, Novo Mesto
Tel: +386 7 337 6650
parker.slovenia@parker.com

TH – Thailand, Bangkok
Tel: +662 717 8140

TR – Turkey, Istanbul
Tel: +90 216 4997081
parker.turkey@parker.com

TW – Taiwan, Taipei
Tel: +886 2 2298 8987

UA – Ukraine, Kiev
Tel: +380 44 494 2731
parker.ukraine@parker.com

UK – United Kingdom, Warwick
Tel: +44 (0)1926 317 878
parker.uk@parker.com

US – USA, Cleveland (industrial)
Tel: +1 216 896 3000

US – USA, Lincolnshire (mobile)
Tel: +1 847 821 1500

VE – Venezuela, Caracas
Tel: +58 212 238 5422

ZA – South Africa, Kempton Park
Tel: +27 (0)11 961 0700
parker.southafrica@parker.com

European Product Information Centre
Free phone: 00 800 27 27 5374
(from AT, BE, CH, CZ, DE, DK, EE, ES, FI,
FR, IE, IT, NL, NO, PL, RU, SE, SK, UK, ZA)

US Product Information Centre
Free phone: 1-800-27 27 537

www.parker.com

Your local authorized Parker distributor

