

DENISON HYDRAULICS

Gold Cup Series

piston pumps for open & closed circuits

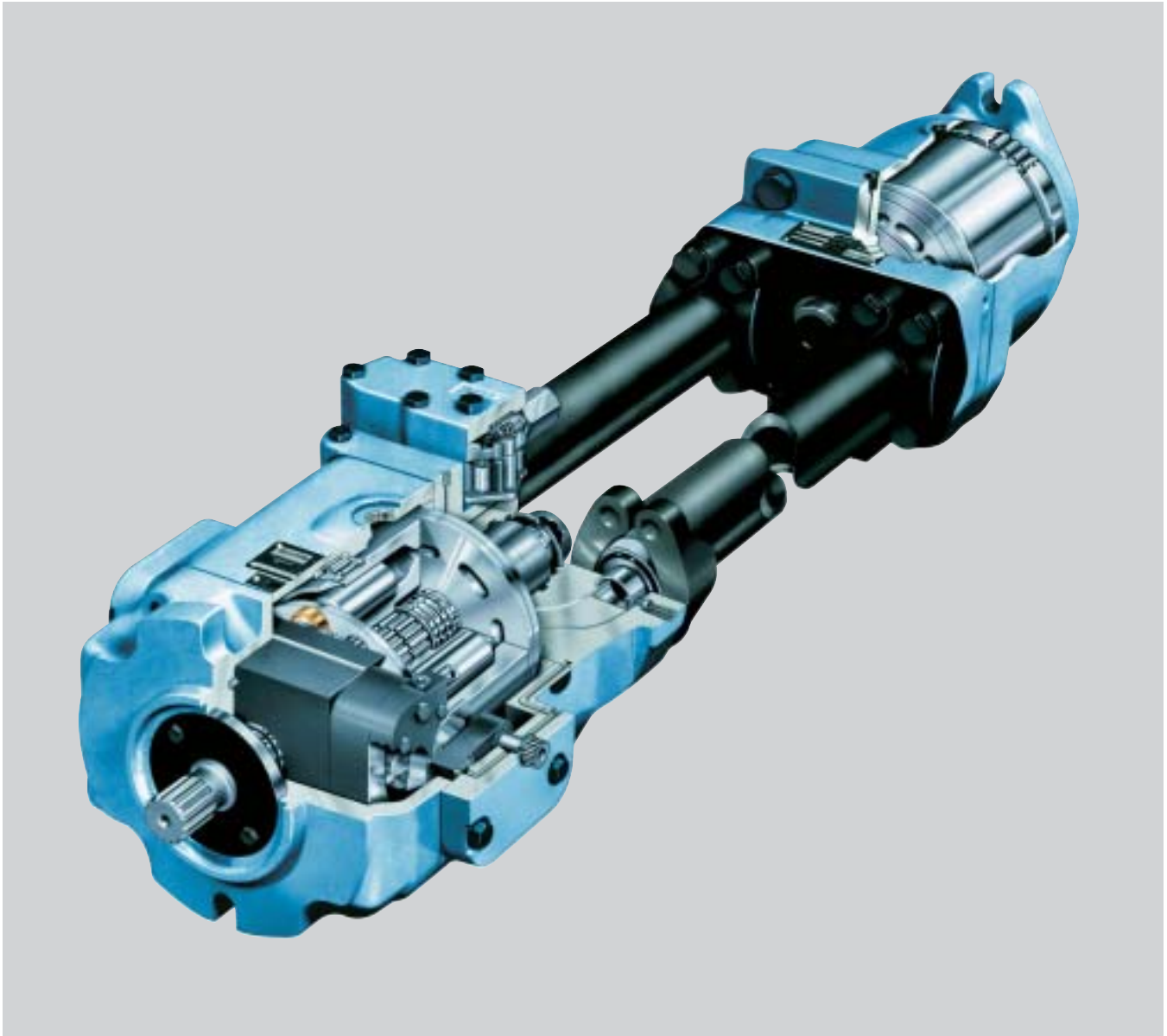

Publ.1 - LT3-00010-1 Replaces 1-AM0021-A

4/03

DENISON Hydraulics

Internet: <http://www.denisonhydraulics.com> E-mail: denison@denisonhydraulics.com



The product information, specifications, and descriptions contained in this publication have been compiled for the use and convenience of our customers from information furnished by the manufacturer; and we can not, and do not, accept any responsibility for the accuracy or correctness of any description, calculation, specification, or information contained herein. No such description, calculation, specification, or information regarding the products being sold has been made part of the basis of the bargain, nor has same created or amounted to an express warranty that the products would conform thereto. We are selling the goods and merchandise illustrated and described on this publication on an "as is" basis, and disclaim any implied warranty, including any warranty of merchantability or warranty of fitness for any particular purpose whatsoever, with respect to the goods and merchandise sold. All manufacturer warranties shall be passed on to our customers, but we shall not be responsible for special, indirect, incidental, or consequential damages resulting from the use of any of the products or information contained or described on this publication. Further, we reserve the right to revise or otherwise make product improvements at any time without notification.

PAGE	
contents	3
technical data	4
features	7
description	8
pump, motor dimensions	
P6, 7, 8	10
M6, 7, 8	14
P11, 14	17
M11, 14	21
P24, 30	24
M24, 30	29
controls dimensions	
10, 2A	34, 41
2H, 4A	35
5A, 5C	36, 42
7D, 7J	37
7F, 7K	38
8A, 8C	39, 41
9A, 9C	40, 42
**4	43
**6, **8, **2	44
rear adapters	
table	45
P6,7,8	46
P11,14	47
P24,30	50
inlet conditions	54
performance curves	55
pump primary displacement control options	61
secondary control options	69
hydraulic schematics	71
pump ordering code	76
motor ordering code	80

TECHNICAL DATA

Series		Terms	P6	P7	P8	P11	P14	P24	P30
Displacement	<i>Max. displacement</i>	in ³ /rev.	6.00	7.25	8.00	11.00	14.00	24.60	30.60
		cm ³ /rev.	98,3	118,8	131,1	180,3	229,5	403,2	501,5
Pressure	<i>Continuous</i>	psi	5000	5000	3600	5000	5000	5000 ¹⁾	5000 ¹⁾
		bar	350	350	250	350	350	350 ¹⁾	350 ¹⁾
	<i>Intermittent</i>	psi	6000 ⁷⁾	6000 ⁷⁾	4500 ⁷⁾	6000 ⁷⁾	6000 ⁷⁾	5000 ¹⁾⁷⁾	5000 ¹⁾⁷⁾
		bar	420 ⁷⁾	420 ⁷⁾	310 ⁷⁾	420 ⁷⁾	420 ⁷⁾	350 ¹⁾⁷⁾	350 ¹⁾⁷⁾
Speed (Pump)	<i>max. @ full stroke</i>	rpm	3000	3000	2100	2400	2400	2100 ²⁾	1800
	<i>(Motor) max. @ full stroke</i>	rpm	3000	3000	NA	2400	2400	2100 ²⁾	1800
	<i>(Motor) max. @ 50% stroke</i>	rpm	3600	3600	NA	2800	2800	2100 ²⁾	1800
Mounting	<i>Flange -2 bolt</i>	SAE	127-2 (C)	127-2 (C)	127-2 (C)	-	-	-	-
		SAE	152-4 (D)	152-4 (D)	152-4 (D)	165-4 (E)	165-4 (E)	177-4 (F)	177-4 (F)
	<i>Flange -4 bolt (opt. on 6,7 & 8)</i>	SAE	32-1 (C)	32-1 (C)	32-1 (C)	44-1 (E)	44-1 (E)	50-1 (F)	50-1 (F)
		SAE	44-1 (D)	44-1 (D)	44-1 (D)	-	-	-	-
	<i>Shaft - keyed</i>	SAE	32-4 (C)	32-4 (C)	32-4 (C)	44-4 (E)	44-4 (E)	50-4(F)	50-4 (F)
		SAE	44-4 (D)	44-4 (D)	44-4 (D)	-	-	-	-
Weight (Pump) less controls		lbs	175-300	175-300	175-300	325-530	325-530	750-835	750-835
	<i>Mass</i>	kg.	80-135	80-135	80-135	145-240	145-240	340-375	340-375
Weight (Motor Fixed)		lbs	110	110	N/A	250	250	510	600
	<i>Mass</i>	kg.	50	50	N/A	110	110	230	270
Weight (Motor Variable) less controls		lbs	110	110	N/A	300	300	650	670
	<i>Mass</i>	kg.	50	50	N/A	135	135	290	300
Rotating inertia		lbs-in ²	92	92	92	290	290	821	977
		kg.m ²	0,027	0,027	0,027	0,085	0,085	0,240	0,286
Torque (Motor) theo. max.	<i>per 100 psi</i>	lbs-in	95.5	115.4	NA	175	222	392	487
		Nm	157	189	NA	287	362	623	797
	<i>at 5000 psi</i>	lbs-in	4774	5769	NA	8750	11100	19576	24351
		Nm	539,5	651,9	NA	990	1250	2158	2752
Power (Motor) theo. max.at 5000 psi, 350 bar	<i>per 100 rpm</i>	hp	7.6	9.2	NA	13.8	17.6	31.1	38.6
		kW	5,7	6,8	NA	10,3	13,1	23,1	28,8
	<i>at 2000 rpm</i>	hp	151.5	183.1	NA	277.8	353.5	621.3	695
		kW	113.0	136,6	NA	207,0	263,7	463,5	518,2
Torque (Motor) efficiency - approx. stalled	<i>running</i>	% theo.	81	81	NA	81	81	81	81
		% theo.	93	93	NA	93	93	93	93
Case pressure: max. allowable	<i>continuous</i>	psi	75	75	75	75	75	75	75
		bar	5,2	5,2	5,2	5,2	5,2	5,2	5,2
	<i>intermittent</i>	psi	125	125	125	125	125	125	125
		bar	8,6	8,6	8,6	8,6	8,6	8,6	8,6
<i>(Not to exceed 25 psi, 1,7 bar above inlet in open circuit units)</i>									
Flow (Pump) theo.at max.displ.@1500 rpm		gpm	39	47	52	71	91	160	199
		lpm	148	178	197	269	344	606	753
	<i>@1800 rpm</i>	gpm	47	57	62	86	109	192	238
		lpm	178	216	235	326	413	727	901
Displacement (Internal aux. pump)		P6,7,8P,S,V	P11,14P,S	P11,14V	P24P	P24S³⁾	P30P	P30S³⁾	
		in ³ /rev.	1.07	(2) 1.07 ⁴⁾	1.07 ⁵⁾	2.81 ⁶⁾	2.81 ⁶⁾	2.81 ⁶⁾	2.81 ⁶⁾
		cm ³ /rev.	17,5	(2) 17,5	17,5	46,1	46,1	46,1	46,1
Flow (Internal aux. pump)	<i>@1500 rpm</i>	gpm	6.9	(2) 6.9	6.9	18.2	6.5	18.2	6.5
		lpm	26,1	(2) 26,1	26,1	68,9	24,6	69,1	24,6
	<i>@1800 rpm</i>	gpm	8.3	(2) 8.3	8.3	21.9	7.8	21.9	7.8
		lpm	31,4	(2) 31,4	31,4	82,9	29,5	82,9	29,5

1) Max. pressure 4000 psi, (275 bar) for M24 and 30 series variable motors. Consult Denison for higher pressure applications.

2) On HF-1 fluids, 1800 RPM Max. on HF-0 fluids.

3) Internal cartridge provides servo flow and must be supercharged from external replenishing flow, from external auxiliary pump.

4) One servo cartridge and one replenishing cartridge.

5) Servo cartridge only.

6) Standard, other sizes available, see ordering code.

7) 10% of operation time, not exceeding 6 successive seconds.

TECHNICAL DATA

Replenishing pressure (<i>Internal aux. pump</i>)		P6,7,8,11,14,24P	P6,7,8,11,14,24S	P30P	P30S
<i>Replenish pressure minus case pressure</i>	psi	180-220	330-370	180-220	420-460
	bar	12,4-15,2	22,8-25,5	12,4-15,2	29,0-31,7
Servo pressure (<i>Internal aux. pump</i>)	psi	400-520	590-690	440-540	670-770
<i>Servo pressure minus case pressure at 0 psi, 0 bar discharge pressure</i>	bar	27,6-35,9	40,7-47,6	30,3-37,2	46,2-53,1
Servo pressure (<i>Internal aux. pump</i>)	psi	600-720	790-890	740-840	970-1070
<i>Servo pressure minus case pressure at 5000 psi, 350 bar discharge pressure</i>	bar	41,4-49,7	54,5-61,4	51,0-57,9	66,9-73,8
Servo pressure (<i>Internal aux. pump</i>)	psi	500-600	500-600	500-600	500-600
<i>for HI-IQ control units. Servo pressure minus case pressure at 5000 psi, 350 bar discharge pressure - at system pressure range 0 to 5000 psi, 350 bar.</i>	bar	37,2-44,1	37,2-44,1	37,2-44,1	37,2-44,1

Series	Terms	P6	P7	P8	P11	P14	P24	P30
Controls								
Compensator response (per SAE J497 @ 5000 psi , 350 bar)	off-stroke sec.	0.05	0.05	0.05	0.07	0.07	0.10	0.10
	on-stroke sec.	0.9	0.9	0.9	1.5	1.5	1.8	1.8
Compensator adjustment	psi/turn	2000	2000	2000	2000	2000	2000	2000
	bar/turn	138	138	138	138	138	138	138
Min. comp. override pressure at above listed min. servo. (servo, electric & hydraulic stroker)	psi	100	100	100	100	100	100	100
	bar	6.7	6.7	6.7	6.7	6.7	6.7	6.7
Servo shaft rotation, 0 to full stroke	degrees	19°	19°	19°	19°	19°	19°	19°
Torque to turn rotary servo shaft	in.-lbs	20	20	20	20	20	20	20
	Nm	2,3	2,3	2,3	2,3	2,3	2,3	2,3

The maximum inlet at the auxiliary pump inlet is 200 psi. (13,8 bar)

Any inlet pressures above atmospheric will increase noise levels and decrease efficiencies noted in this literature. Exact measurements depend on each application and operating conditions. Please consult your nearest Denison Office for further details.

Minimum compensating pressure is 100 psi (6.9 bar) over servo.

For recommended fluids, temperature and fluid cleanliness, see Denison Hydraulics bulletin SPO-AM305 for more details.

REAR DRIVE TORQUE CAPACITY

SERIES	FRONT INPUT SHAFT		REAR MOUNTINGS SAE						REAR OUTPUT SHAFT TORQUE CAPACITY
	TYPE	TORQUE CAPACITY	A	B	C	D	E	F	
P6,7,8 P,S,V	Keyed SAE 32-1(C) Spline SAE 32-4(C)	6920 in-lbs. (780 Nm)	•	•					1750 in-lbs. (195 Nm)
P6,7,8 P,S,V	Keyed SAE 44-1(D) Spline SAE 44-4(D)	6920 in-lbs. (780 Nm)	•	•					1750 in-lbs. (195 Nm)
P6,7,8 R,L only	Keyed SAE 32-1(C)* Spline SAE 32-4C	13,845 in-lbs. (1565 Nm)			•				6920 in-lbs. (780 Nm)
P11,14 P,S,V	Keyed SAE 44-1(E) Spline SAE 44-4(E)	13,370 in-lbs. (1510 Nm)	•	•					2400 in-lbs. (270 Nm)
P11,14 R,L only	Keyed SAE 44-1(E)* Spline SAE 44-4(E)	26735 in-lbs. (3020 Nm)			•	•	•		13,370 in-lbs. (1510 Nm)
P24,30 P,S,	Keyed SAE 50-1(F) Spline SAE 50-4(F)	24350 in-lbs. (2750 Nm)		•	•				2700 in-lbs. (305 Nm)
P24,30 R,L only	Keyed SAE 50-1(F) Spline SAE 50-4(F)	48,700* in-lbs. (5,500 Nm)				•	•	•	24,350 in-lbs (2750 Nm)

* Coupling for keyed shaft must be pressed fit.

P6/7/8 SAE 127-2 Mtg., 32-1, 4 Shaft Bearing 230-82140 (6007)

Speed (rpm)	1000	1000	1000	1000	1200	1200	1200	1200	1500	1500	1500	1500	1800	1800	1800	1800
Shaft Load (lbs)	1	1	1000	1000	1	1	1000	1000	1	1	1000	1000	1	1	1000	1000
Shaft Load (N)	4	4	4448	4448	4	4	4448	4448	4	4	4448	4448	4	4	4448	4448
Case Pressure (psi)	0	25	0	25	0	25	0	25	0	25	0	25	0	25	0	25
Case Pressure (bar)	0.0	1.7	0.0	1.7	0.0	1.7	0.0	1.7	0.0	1.7	0.0	1.7	0.0	1.7	0.0	1.7
B-10 Life (hours x 1000)	8E+08	1833	0.778	0.778	6E+08	1528	0.648	0.648	5E+08	1222	0.518	0.518	4E+08	1018	0.432	0.432

P6/7/8 SAE 152-4 Mtg., 44-1, 4 Shaft Bearing 230-00207-0 (6207)

Speed (rpm)	1000	1000	1000	1000	1200	1200	1200	1200	1500	1500	1500	1500	1800	1800	1800	1800
Shaft Load (lbs)	1	1	1000	1000	1	1	1000	1000	1	1	1000	1000	1	1	1000	1000
Shaft Load (N)	4	4	4448	4448	4	4	4448	4448	4	4	4448	4448	4	4	4448	4448
Case Pressure (psi)	0	25	0	25	0	25	0	25	0	25	0	25	0	25	0	25
Case Pressure (bar)	0.0	1.7	0.0	1.7	0.0	1.7	0.0	1.7	0.0	1.7	0.0	1.7	0.0	1.7	0.0	1.7
B-10 Life (hours x 1000)	3E+09	7394	3.136	3.136	3E+09	6161	2.613	2.613	2E+09	4929	2.09	2.09	2E+09	4170	1.742	1.742

P11/14 SAE 165-4 Mtg., 44-1, 4 Shaft Bearing 230-82148-0 (6010)

Speed (rpm)	1000	1000	1000	1000	1200	1200	1200	1200	1500	1500	1500	1500	1800	1800	1800	1800
Shaft Load (lbs)	0	0	1000	1000	0	0	1000	1000	0	0	1000	1000	0	0	1000	1000
Shaft Load (N)	0	0	4448	4448	0	0	4448	4448	0	0	4448	4448	0	0	4448	4448
Case Pressure (psi)	0	25	0	25	0	25	0	25	0	25	0	25	0	25	0	25
Case Pressure (bar)	0.0	1.7	0.0	1.7	0.0	1.7	0.0	1.7	0.0	1.7	0.0	1.7	0.0	1.7	0.0	1.7
B-10 Life (hours x 1000)	2E+09	535	1.907	1.907	2E+09	446	1.589	1.589	1E+09	356	1.272	1.272	1E+09	297	1.06	1.06

P11/14 SAE 165-4 Mtg., 44-1, 4 Shaft Bearing 230-82214-0 (22208)

Speed (rpm)	1000	1000	1000	1000	1200	1200	1200	1200	1500	1500	1500	1500	1800	1800	1800	1800
Shaft Load (lbs)	0	0	1000	1000	0	0	1000	1000	0	0	1000	1000	0	0	1000	1000
Shaft Load (N)	0	0	4448	4448	0	0	4448	4448	0	0	4448	4448	0	0	4448	4448
Case Pressure (psi)	0	25	0	25	0	25	0	25	0	25	0	25	0	25	0	25
Case Pressure (bar)	0.0	1.7	0.0	1.7	0.0	1.7	0.0	1.7	0.0	1.7	0.0	1.7	0.0	1.7	0.0	1.7
B-10 Life (hours x 1000)	16856	2452	275	172	14046	2043	230	143	11237	1635	184	114.8	9364	1363	153	95.7

P24 SAE 177-4 Mtg., 50-1, 4 Shaft Bearing 230-82213-0 (22311)

Speed (rpm)	1000	1000	1000	1000	1200	1200	1200	1200	1500	1500	1500	1500	1800	1800	1800	1800
Shaft Load (lbs)	0	0	1000	1000	0	0	1000	1000	0	0	1000	1000	0	0	1000	1000
Shaft Load (N)	0	0	4448	4448	0	0	4448	4448	0	0	4448	4448	0	0	4448	4448
Case Pressure (psi)	0	25	0	25	0	25	0	25	0	25	0	25	0	25	0	25
Case Pressure (bar)	0.0	1.7	0.0	1.7	0.0	1.7	0.0	1.7	0.0	1.7	0.0	1.7	0.0	1.7	0.0	1.7
B-10 Life (hours x 1000)	591.6	428.5	276.7	213.5	493	357	230.5	178	394.4	991.6	184.4	142.3	328.7	238	153.7	118.6

P30 SAE 177-4 Mtg., 50-1, 4 Shaft Bearing 230-82213-0 (22311)

Speed (rpm)	1000	1000	1000	1000	1200	1200	1200	1200	1500	1500	1500	1500	1800	1800	1800	1800
Shaft Load (lbs)	0	0	1000	1000	0	0	1000	1000	0	0	1000	1000	0	0	1000	1000
Shaft Load (N)	0	0	4448	4448	0	0	4448	4448	0	0	4448	4448	0	0	4448	4448
Case Pressure (psi)	0	25	0	25	0	25	0	25	0	25	0	25	0	25	0	25
Case Pressure (bar)	0.0	1.7	0.0	1.7	0.0	1.7	0.0	1.7	0.0	1.7	0.0	1.7	0.0	1.7	0.0	1.7
B-10 Life (hours x 1000)	227	177.7	126.4	102.8	189.2	148	105.3	85.6	151.3	118.4	84.2	68.5	126.1	98.7	70.2	57.1

*radial load at center of key

Note: Variation in life is due to variations in tolerances within the pump.

Contact DENISON Hydraulics for B-10 with other operating conditions and with other case pressure values.

Consult Denison Hydraulics for shaft side loads of P*R units.

FEATURES

- | | | |
|--|--|---|
| <p>1 Quick change valve block - easy to service or replace</p> <p>2 Quick change controls - easy to service and change</p> <p>3 Dampened low inertia rocker cam - more stable, quieter and faster than other designs</p> <p>4 Exclusive zero-backlash rotary servo design - lifetime accuracy</p> <p>5 Field adjustable compensator override - easily adjusted without removing from machinery</p> <p>6 Precision barrel bearing, a distinctive Denison Hydraulics feature for over 30 years - permits high speeds, high pressure and provides long life</p> <p>7 Versatile controls - can be located on either side of pump or motor for maximum freedom of design</p> <p>8 Patented ring style replenishing checks fastest operation with no sliding poppets or parts and low pressure drop</p> <p>9 Hot oil shuttle available - fast, reliable operation</p> | <p>10 Auxiliary pump can be changed without disassembling the transmission</p> <p>11 Standard SAE keyed or splined drive shafts are available</p> <p>12 High pressure mechanical shaft seals can be changed without disassembling the transmission. Double lip seals are also available</p> <p>13 One piece stroking vane/cam means no lost motion, zero backlash, better control, and no linkages to wear out</p> <p>14 Stroking vane seals are pressure loaded for longer life</p> <p>15 Standard compensator vent ports allow for a wide variety of controls (See Controls Manual)</p> <p>16 Rocker cam displacement indicator helps troubleshoot the system</p> | <p>17 Modulated servo pressure saves power</p> <p>18 Standard Code 62 SAE split flange connections</p> <p>19 Conforms to SAE mounting standards. These products are qualified to meet Military specifications MIL-P-17869A and MIL-S-901-C Grade A</p> <p>20 Fastest compensator response: Gives maximum of 10% pressure overshoot at rated conditions (guaranteed times under all conditions faster response times possible depending upon application)</p> <p>21 Variable motors available for multiple speed ranges or constant power</p> |
|--|--|---|

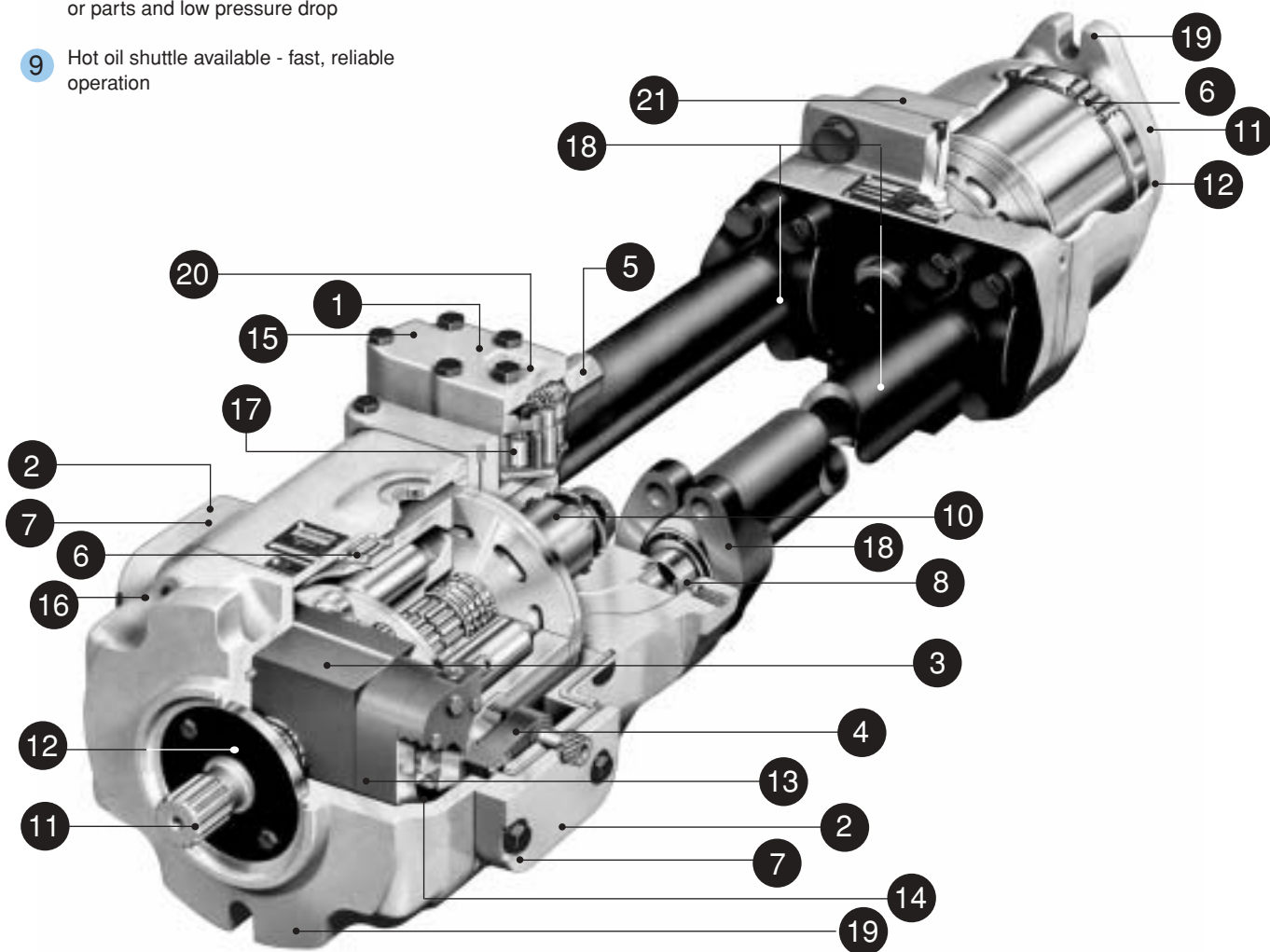

CLOSED HYDRAULIC CIRCUIT

Variable Pump/Fixed Motor. This combination provides for a constant torque output at a fixed maximum pressure over the full speed range. Speed and direction are controlled with a variable displacement over-center pump. Power from overhauling loads is regenerated back into the pump prime mover. Motor speed is limited to the maximum speed permitted by full pump displacement. System is capable of full power only at maximum pump displacement.

POWER CHARACTERISTICS OF HYDROSTATIC TRANSMISSIONS

Variable Pump/Variable Motor. This combination provides for an extended range of motor speeds. The motor, at full displacement, delivers maximum torque while its speed and direction respond to displacement changes of the crossover center pump. Power is proportional to motor speed.

This transmission system has the capability of constant torque and rising power until the pump reaches full displacement and full power at elevated speeds as motor displacement and torque are reduced.

PACKAGE PUMP

The package pump contains the circuit elements shown in the hydraulic schematic on pgs. 56-58. These include the axial piston over-center variable displacement pump which controls the speed and direction of the motor, the auxiliary pump which supplies servo pressure (for controlling the displacement of the variable pump) and replenishment pressure, the servo pressure relief valve, the replenishment pressure relief valve and the replenishment check valves for ports A and B. The pump package also includes the displacement control valves as well as an external arm which shows actual displacement. The various control features are described below.

PACKAGE MOTOR

The package motor, shown in schematic pgs. 56-58, contains the axial piston fluid motor, the shuttle valve that continuously removes hot oil from the low pressure side of the loop and a relief valve to establish minimum hydraulic loop pressure at the motor. The fluid motor is available with fixed displacement or with the variable displacement option. The standard variable motors include an external indicator which shows displacement.

OPEN CIRCUIT PUMP

The open circuit pump contains the circuit elements shown on pages 59,60. These include a cross-center variable displacement pump which is normally limited to one side of center. The auxiliary pump supplies only servo pressure to control the main pump displacement and inlet porting is enlarged to improve the pump's inlet characteristics. As the open loop pump operates on one side of center only, not all controls are available.

AUXILIARY REAR DRIVE

Additional auxiliary flow is available with the rear drive pump option. The rear drive may also be utilized for servo and other purposes. See ordering code for additional detail.

"R" & "L" style pumps have no rear shaft seal, so any pump driven must be able to withstand case pressure of the pump driving it.

AUXILIARY PUMP

Integral to the package pump's envelope is the gerotor auxiliary pump. (P24P, P24S, P30P & P30S have vane integral pump). It provides servo and replenishing pressure. See page 5 for factory settings.

NOTE: Auxiliary pump inlet must be connected directly to the reservoir. Customer must supply external line from integral auxiliary pump back into main pump for filtering servo and/or replenishing oil. (see installation drawings starting on pg 10.)

MOUNTING

The pump or motor is designed to operate in any position. For vertical mounting it is recommended that the shaft bearing be drained via the drain port provided. The mounting hub and mounting flange are in full conformance with SAE standard. The shaft must be in alignment with the shaft of the driven load and should be checked with a dial indicator. The mounting pad or adapter into which the fluid pump pilots be concentric with the pump shaft within 0.006 in., 0,152 mm to prevent bearing failure. This concentricity is particularly important if the shaft is rigidly connected to the driving load without a flexible coupling. The shaft-coupling interface must be lubricated with lithium molydisulfide or similar grease.

INLET PRESSURES, PORTS A & B

In a closed hydraulic loop the pump inlet or the fluid motor inlet (during dynamic braking) are supercharged by the integral replenishment system. Consult Denison in cases where fluid viscosity or dynamics or line size may cause inlet pressure at either port A or B to be less than the 150 psi, 10,3 bar maintained by the integral replenishment system. For operation in open loop or combination open-closed loops, consult Denison.

DRAIN PORT

Drain the package pump from the higher drain port. If drain port is above the fluid level in the tank install a 5 psi, 0,3 bar relief of suitable size in the drain line to tank. For vertical mounting it is recommended that the shaft bearing be drained via the drain port provided.

For pump speeds intermittently below 1000 rpm, install a back pressure relief 40 psi, 2,8 bar of suitable size in the drain line from the higher port to tank. Motor case drain must be connected to pump case.

Motor: Drain the motor from the higher drain ports into the lower pump drain port or tank. Make provision that the motor drain port pressure will not exceed the maximum limits specified above.

RETURN LINE FILTER

Relatively inexpensive low pressure filters are recommended for installation in the return lines and drain lines from circuits using these pumps or motors. Consider the possibility of decompression surges and intensified flow in cylinder circuits as well as the factors above in selecting return line filters.

AUXILIARY FLOW FILTERS

It is recommended the auxiliary pump fluid be fully filtered to aid in maintaining acceptable cleanliness levels. For good filtration and reasonable maintenance intervals the filter capacity must be at least twice the auxiliary pump flow. To use this feature, install the isolation plug and connect the filter between ports G&H, (P6,P7,P8,P24,P30), or J&K (P11,P14). See detailed schematics and drawings pages 10-19 for location of these ports.

NOTE: Auxiliary and return filters **must** use bypass valves.

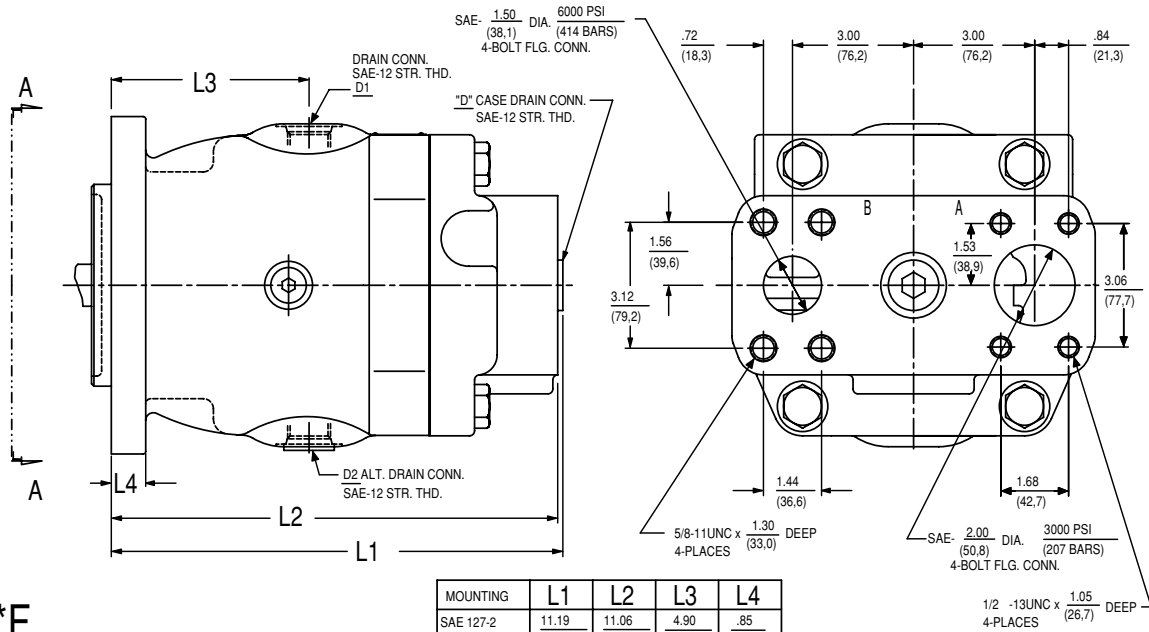

P*F

INSTALLATION DWG. 23-9841-D

MOUNTING	L1	L2	L3	L4
SAE 127-2 (SAE-C)	11.19 (284,2)	11.06 (280,9)	4.90 (124,5)	.85 (21,6)
SAE 152-4 (SAE-D)	11.59 (294,3)	11.46 (291,1)	5.30 (134,6)	.89 (22,6)

P*M

INSTALLATION DWG. 23-10262-D

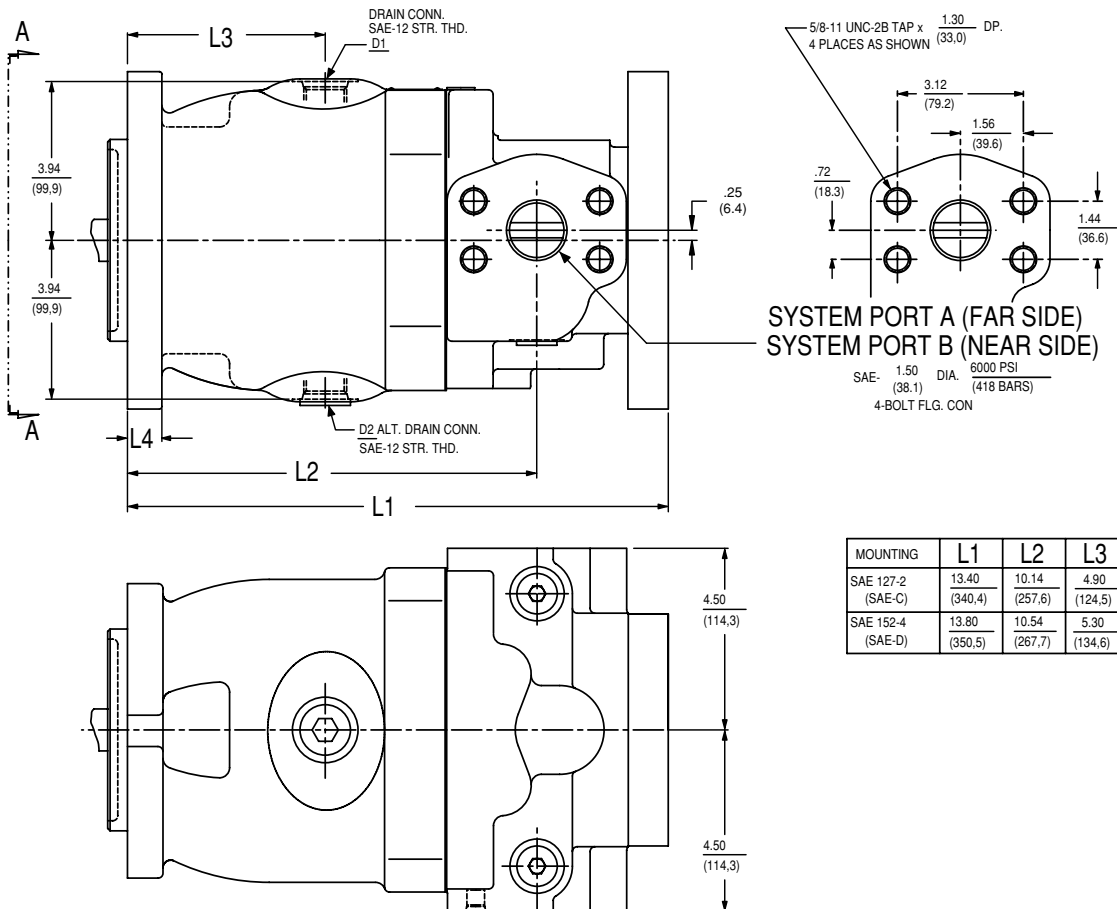

MOUNTING	L1	L2	L3	L4
SAE 127-2 (SAE-C)	13.40 (340,4)	10.14 (257,6)	4.90 (124,5)	.85 (21,6)
SAE 152-4 (SAE-D)	13.80 (350,5)	10.54 (267,7)	5.30 (134,6)	.89 (22,6)

NOTE: See page 16 for shaft information.
See pages 45-53 for rear drive information.

**P6-P7-P8V, D, P DIMENSIONS
(LESS CONTROLS)**

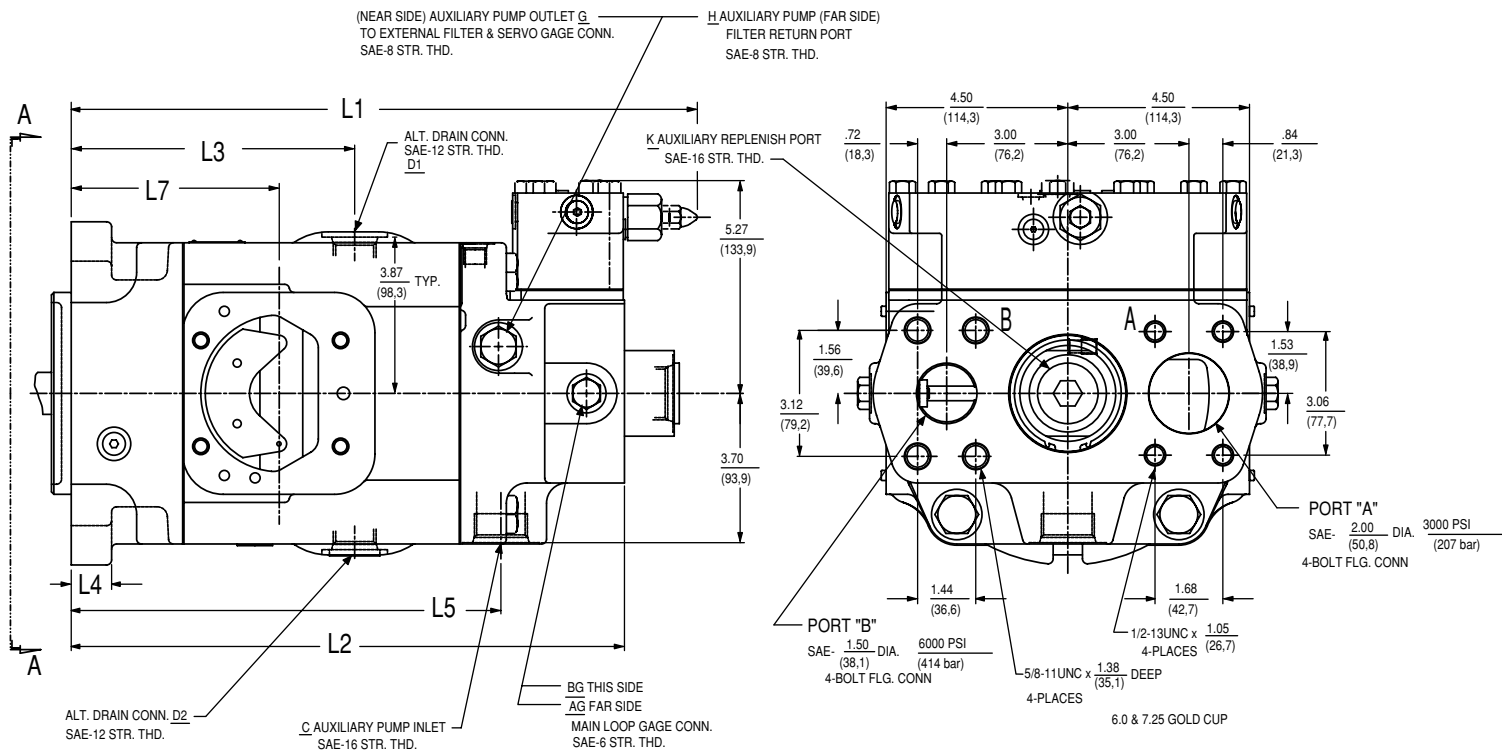
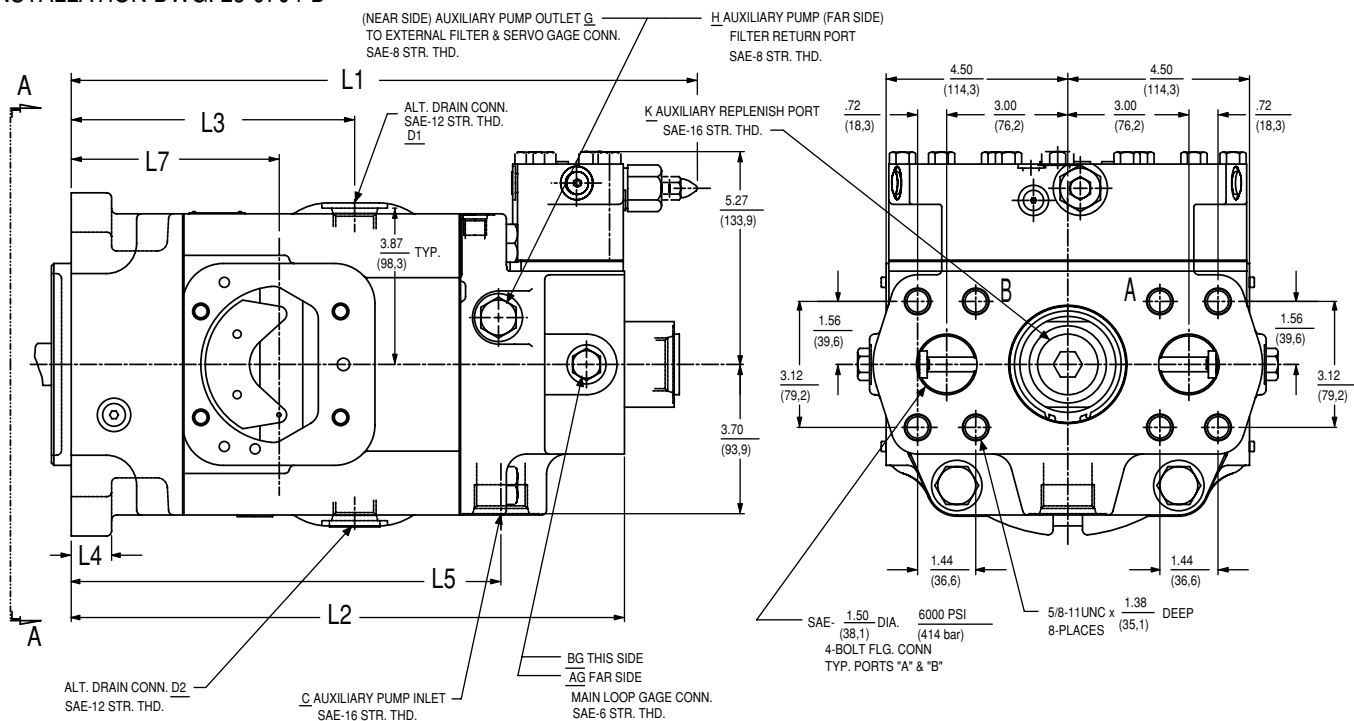

TABLE 1

MOUNTING	L1	L2	L3	L4	L5	L7
SAE 127-2 (SAE-C)	15.51 (393.9)	13.70 (348.0)	7.02 (178.3)	1.00 (25.4)	10.64 (270.3)	5.15 (130.9)
SAE 152-4 (SAE-D)	16.85 (427.9)	15.04 (382.1)	8.36 (212.3)	.86 (21.8)	11.98 (304.3)	6.49 (164.8)

P*V
INSTALLATION DWG. 23-9704-D

P*D & P*P
INSTALLATION DWG. 23-9704-D



NOTE: See page 16 for shaft information.
See appropriate controls mounting starting on page 34.

**P6-P7-P8X, R DIMENSIONS
(LESS CONTROLS)**

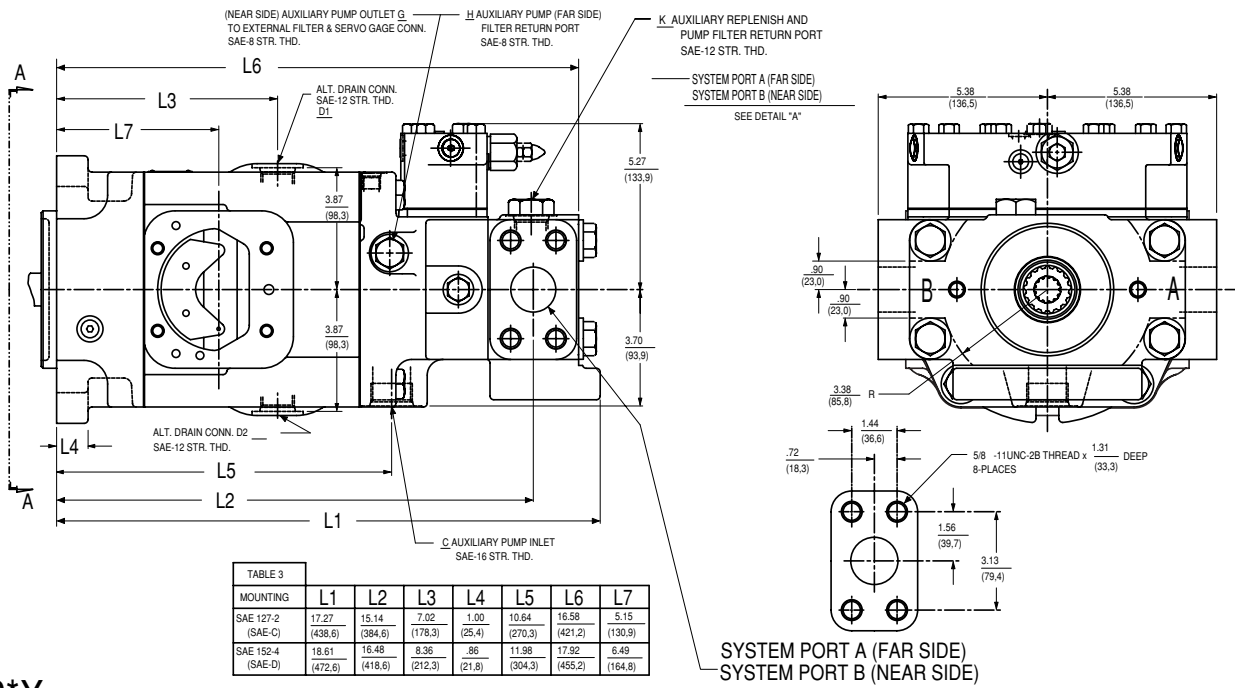

P*X
INSTALLATION DWG. 23-9885-D

P*R
INSTALLATION DWG. 23-9726-D

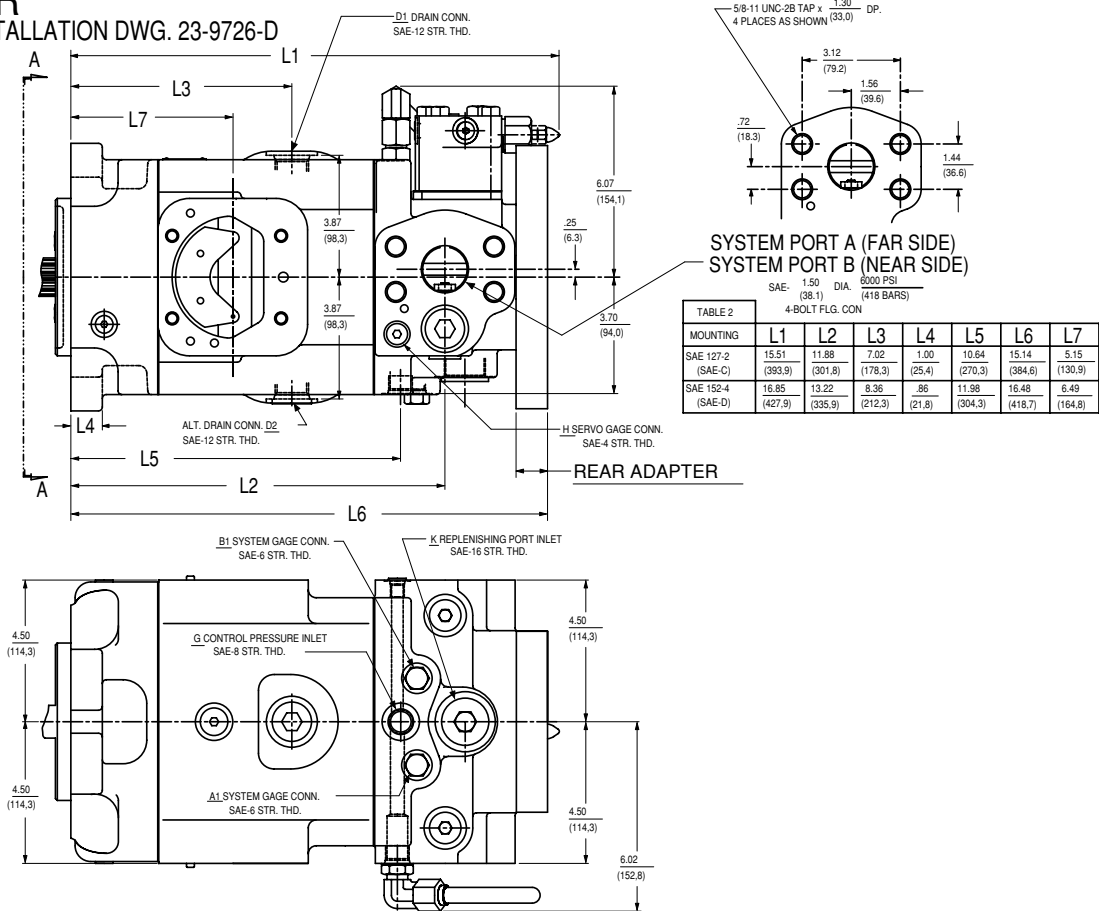

NOTE: See page 16 for shaft information.
See pages 45-53 for rear drive information.
See appropriate controls mounting starting on page 34.

P6-P7-P8S, L DIMENSIONS (LESS CONTROLS)

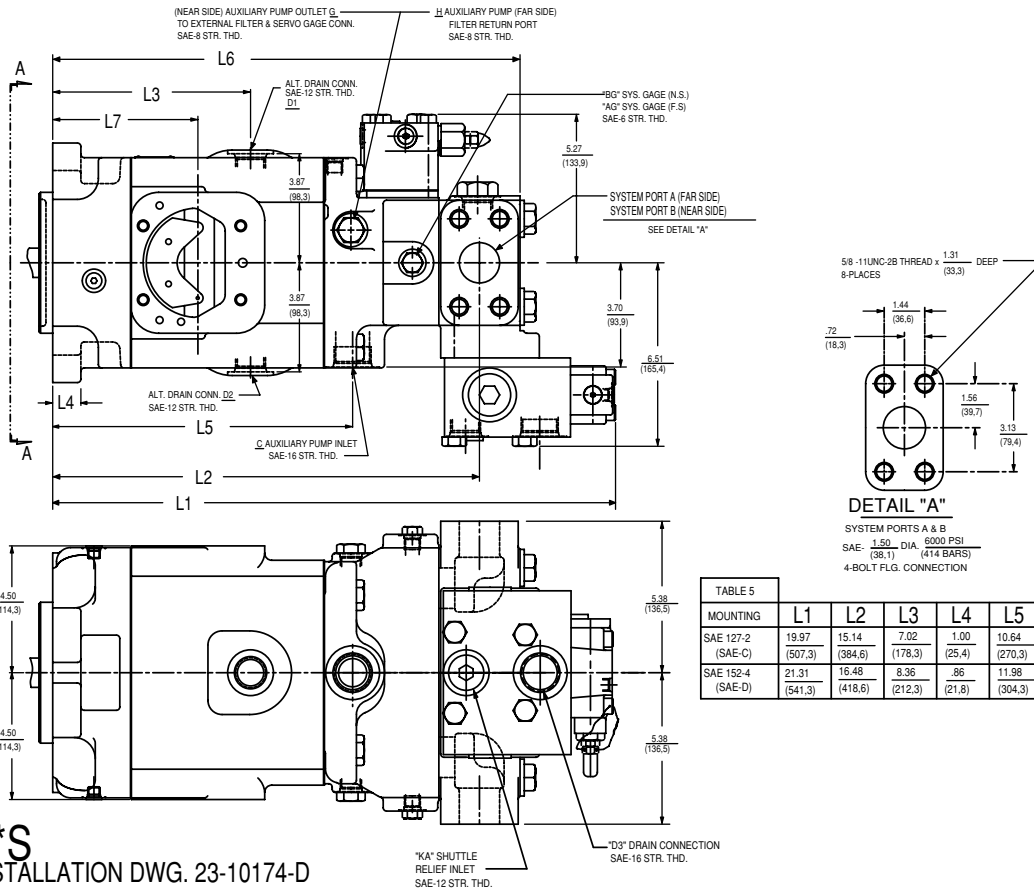

DETAIL "A"

SYSTEM PORTS A & B
SAE- 1.50 DIA. 6000 PSI
(38.1) (414 BARS)
4-BOLT FLG. CONNECTION

TABLE 5							
MOUNTING	L1	L2	L3	L4	L5	L6	L7
SAE 127-2 (SAE-C)	19.97 (507.3)	15.14 (384.6)	7.02 (178.3)	1.00 (25.4)	10.64 (270.3)	16.58 (421.2)	5.15 (130.9)
SAE 152-4 (SAE-D)	21.31 (541.3)	16.48 (418.6)	8.36 (212.3)	.86 (21.8)	11.98 (304.3)	17.92 (455.2)	6.49 (164.8)

P*S
INSTALLATION DWG. 23-10174-D

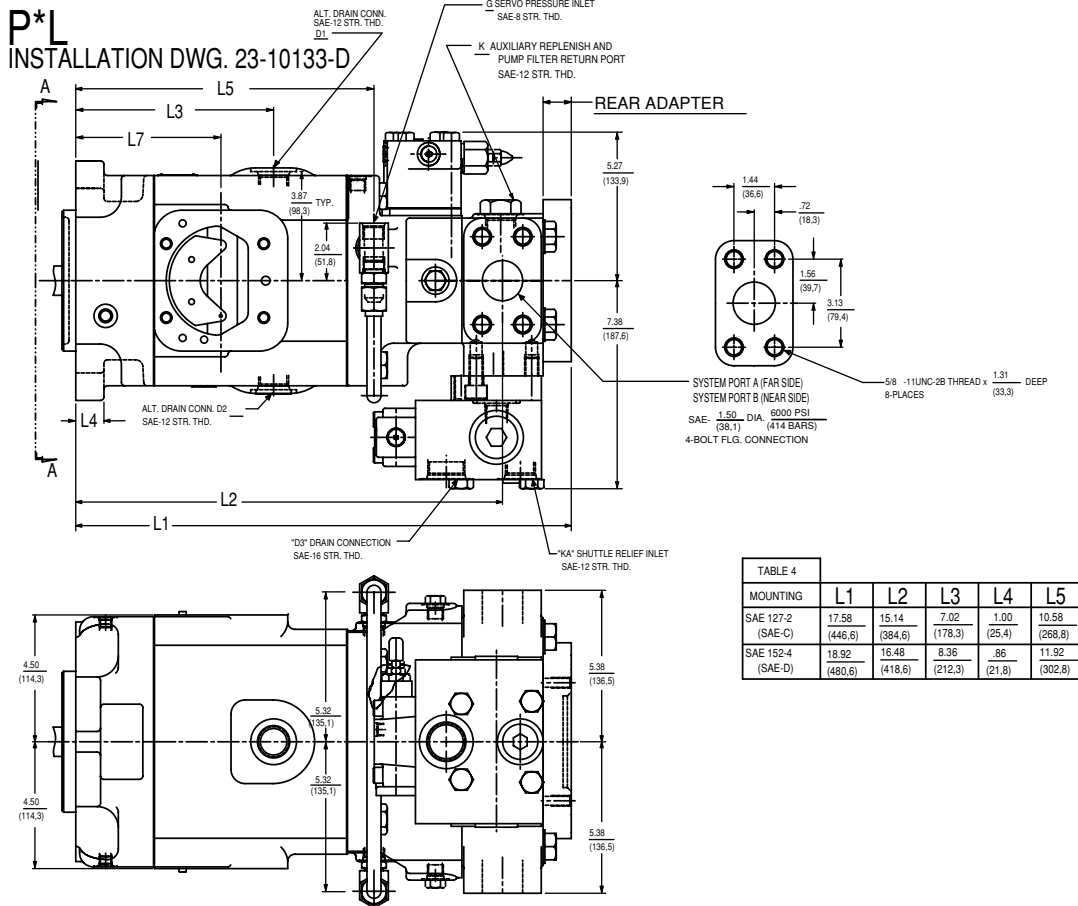

TABLE 4							
MOUNTING	L1	L2	L3	L4	L5	L6	L7
SAE 127-2 (SAE-C)	17.58 (446.6)	15.14 (384.6)	7.02 (178.3)	1.00 (25.4)	10.58 (268.8)	16.58 (421.2)	5.15 (130.9)
SAE 152-4 (SAE-D)	18.92 (480.6)	16.48 (418.6)	8.36 (212.3)	.86 (21.8)	11.92 (302.8)	17.92 (455.2)	6.49 (164.8)

NOTE: See page 16 for shaft information.
See pages 45-53 for rear drive information.
See appropriate controls mounting starting on page 34.

M*F & M*G

INSTALLATION DWG. 23-9294-D

MOUNTING	L1	L2	L3	L4
SAE 127-2 (SAE-C)	11.19 (284.2)	11.06 (280.9)	4.90 (124.5)	.85 (21.6)
SAE 152-4 (SAE-D)	11.59 (294.3)	11.46 (291.1)	5.30 (134.6)	.89 (22.6)

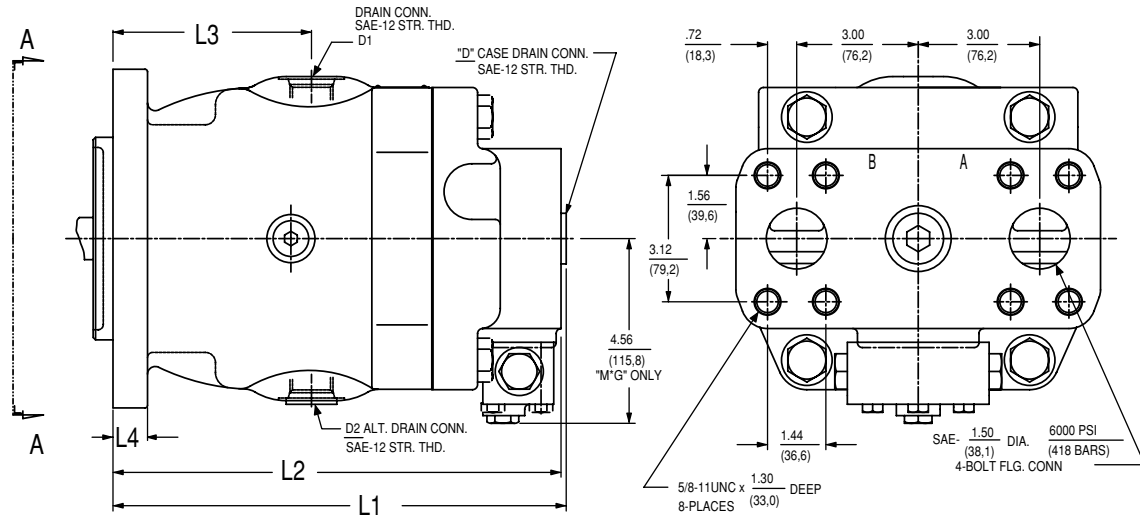

M*M & M*N

INSTALLATION DWG. 23-10262-D

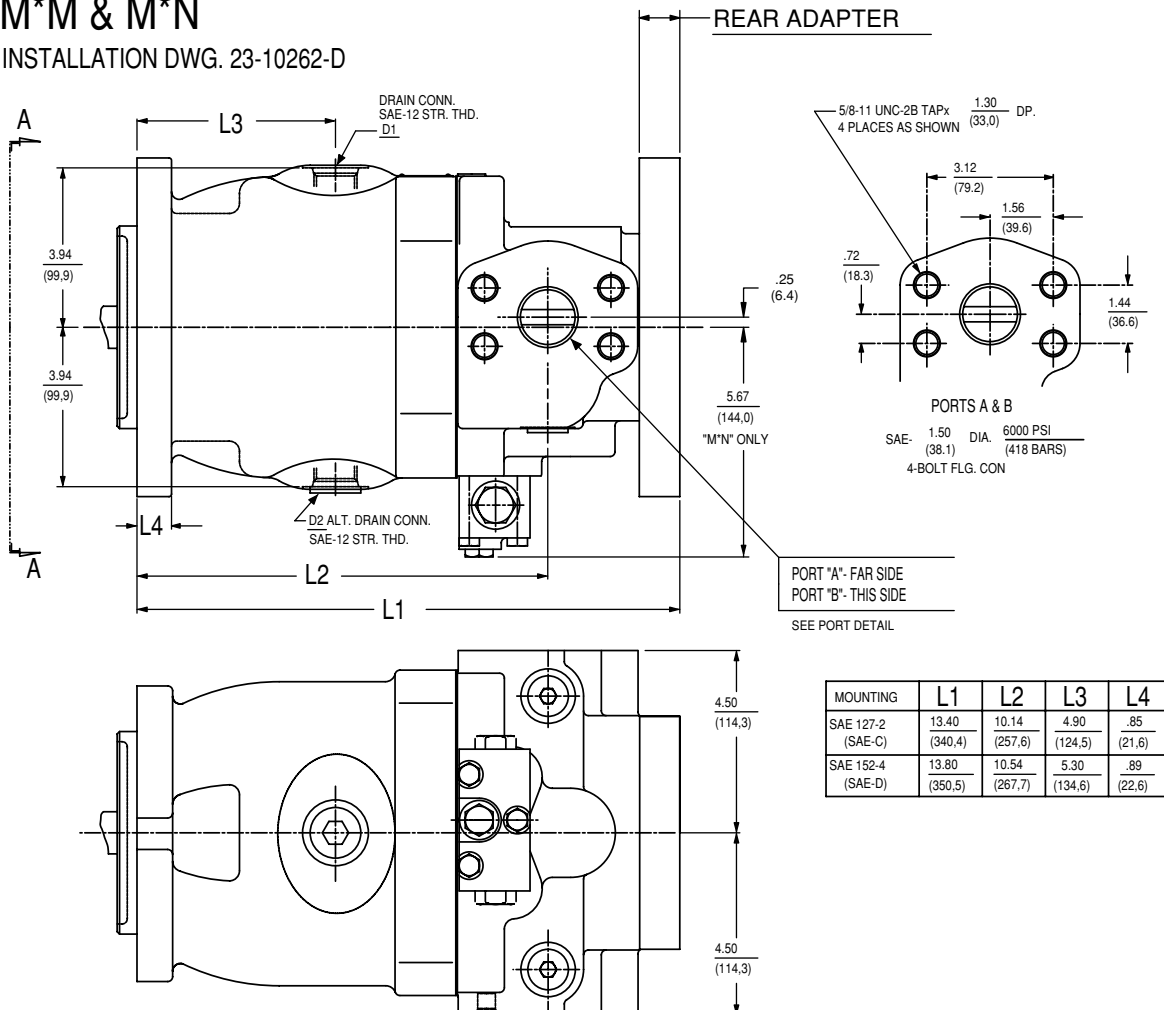

MOUNTING	L1	L2	L3	L4
SAE 127-2 (SAE-C)	13.40 (340.4)	10.14 (257.6)	4.90 (124.5)	.85 (21.6)
SAE 152-4 (SAE-D)	13.80 (350.5)	10.54 (267.7)	5.30 (134.6)	.89 (22.6)

NOTE: See page 16 for shaft information.
See pages 45-53 for rear drive information.

M*H & M*V

INSTALLATION DWG. 23-10029-D

TABLE 14						
MOUNTING	L1	L2	L3	L4	L5	L7
SAE 127-2 (SAE-C)	13.16 (334.3)	12.80 (325.1)	7.02 (178.3)	1.00 (25.4)	10.58 (268.8)	5.15 (130.9)
SAE 152-4 (SAE-D)	14.50 (368.3)	14.14 (359.2)	8.36 (212.3)	.86 (21.8)	11.92 (302.8)	6.49 (164.8)

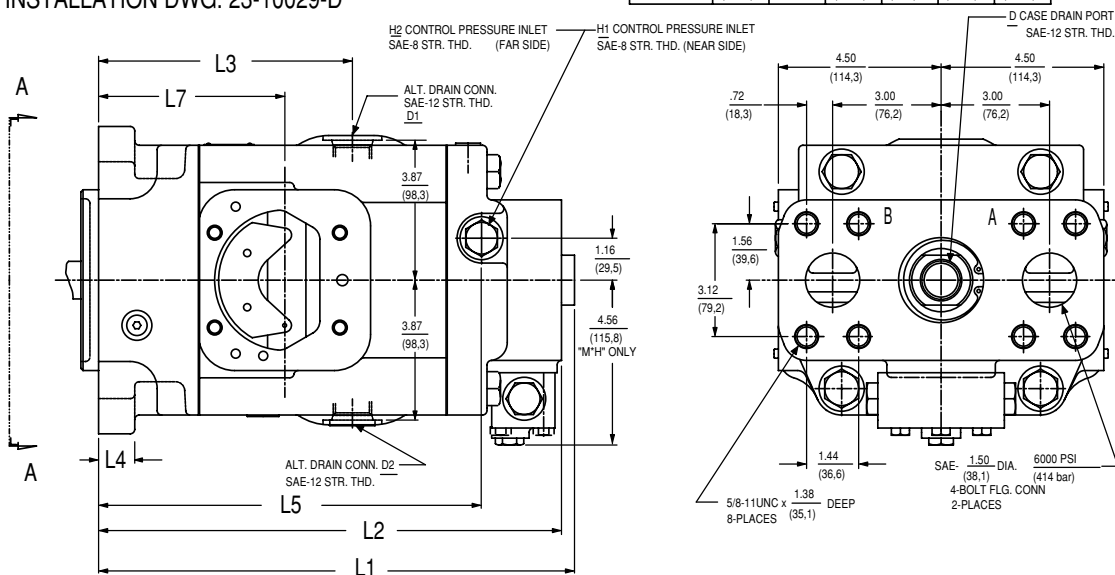

M*R & M*L

INSTALLATION DWG. 23-10317-D

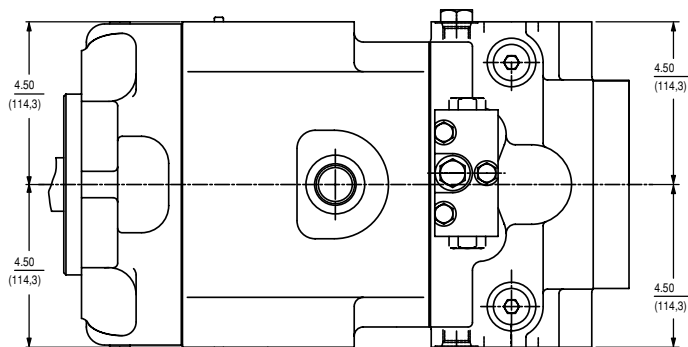
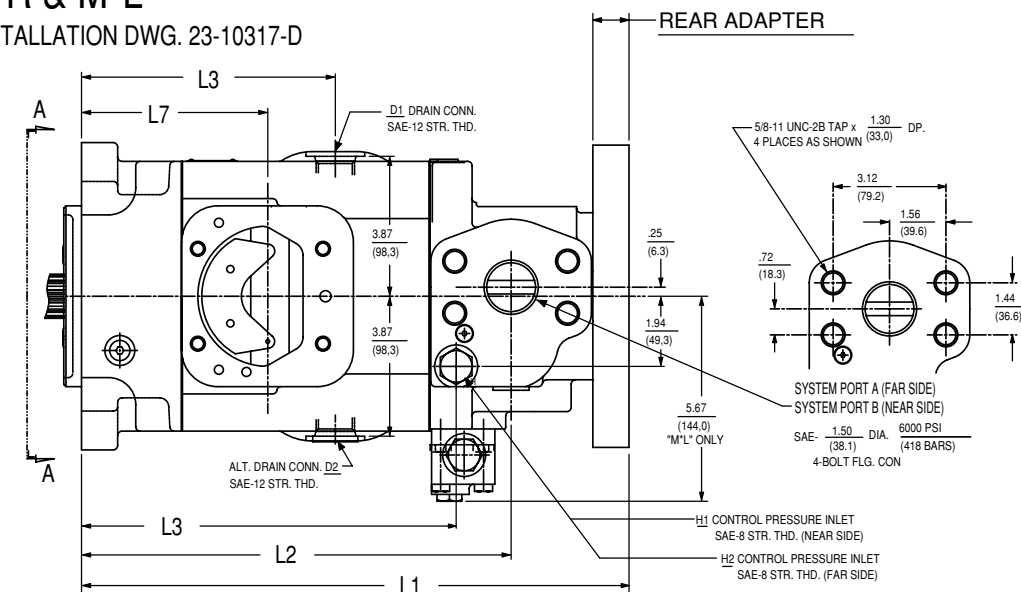
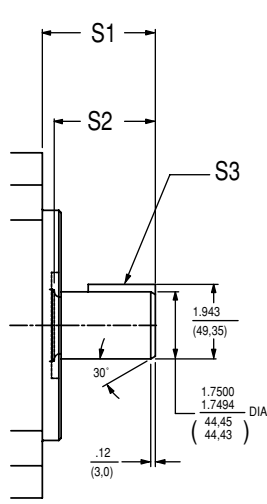

TABLE 13						
MOUNTING	L1	L2	L3	L4	L5	L7
SAE 127-2 (SAE-C)	15.14 (384.6)	11.88 (301.8)	7.02 (178.3)	1.00 (25.4)	10.36 (263.1)	5.15 (130.9)
SAE 152-4 (SAE-D)	16.48 (418.7)	13.22 (335.9)	8.36 (212.3)	.86 (21.8)	11.70 (297.2)	6.49 (164.8)

NOTE: See page 16 for shaft information.
See pages 45-53 for rear drive information.
See appropriate controls mounting starting on page 34.

M*F, M*G, M*H, M*V, P*S, P*X, P*D, P*P, P*V & P*F M*R, M*L, M*M, M*N, P*L & P*R



SAE 152-4 ("D" 4 BOLT)
SAE 44-1
("D" KEYED)

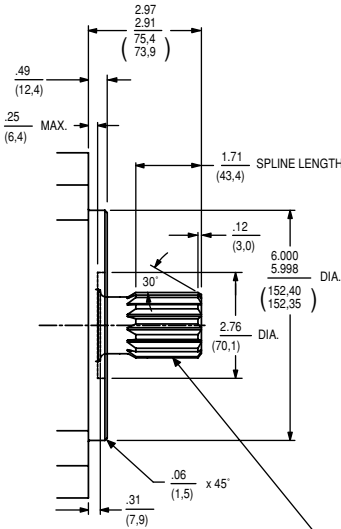

SAE 152-4 ("D" 4 BOLT)
SAE 44-4
("D" SPLINE)

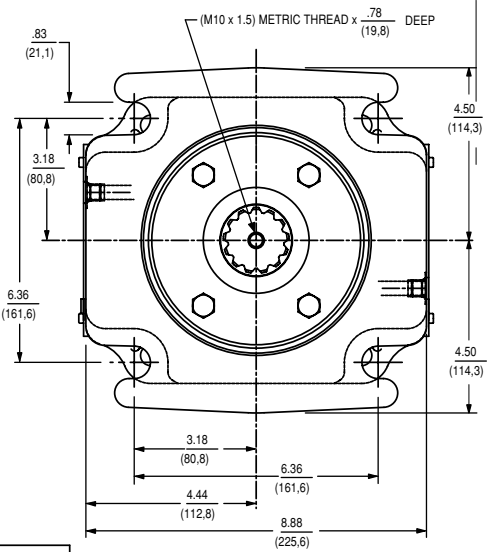

VIEW A-A
FOR SAE 152-4
("D" 4-BOLT)

SHAFT DESIGNATION PUMP MODEL CODE	SHAFT	S1	S2	S3
04	SAE 32-1 (SAE-C)	2.97/2.91 (75.4/73.9)	2.64 (67.0)	.438/.437 (11.12/11.10) SQ. KEY x 1.75 (44.4)

SHAFT DESIGNATION PUMP MODEL CODE	SAE INVOLUTE SPLINE J498-B 1969 EXTERNAL CLASS 1 FLAT ROOT 8/16 DIA. PITCH 30° PRESSURE ANGLE 13 TEETH 1.7210-1.7160 MAJOR DIA (43.713/43.586)	SIDE FIT
05		

NOTES:

- SPLINE LENGTH ONLY FOR:
M*F, M*G, M*H, M*V, P*S, P*X, P*D, P*P, P*V & P*F
- SPLINE LENGTH ONLY FOR:
M*R, M*L, M*M, M*N, P*L & P*R

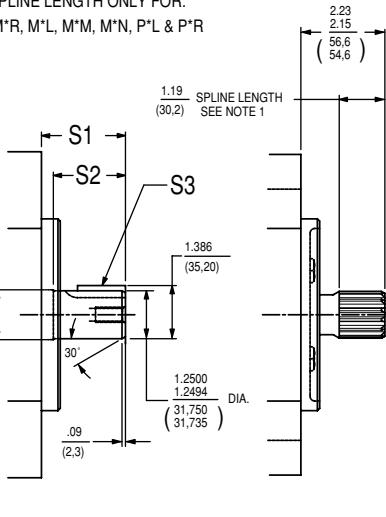

SAE 127-2 ("C" 2-BOLT)
SAE 32-1
("C" KEYED)

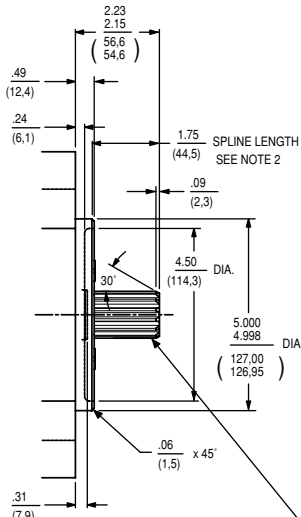

SAE 127-2 ("C" 2-BOLT)
SAE 32-4
("C" SPLINE)

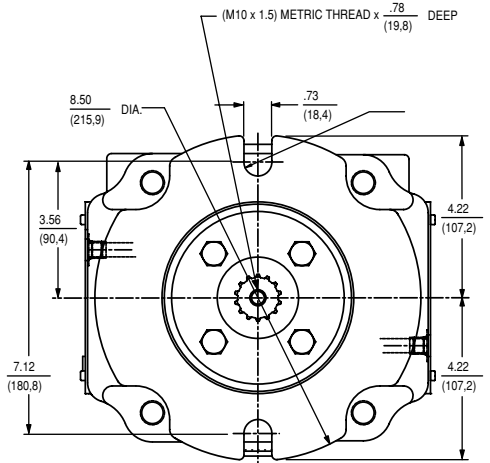

VIEW A-A
FOR SAE 127-2
("C" 2-BOLT)

SHAFT DESIGNATION PUMP MODEL CODE	SHAFT	S1	S2	S3
02 or 07	SAE 32-1 (SAE-C)	2.23/2.15 (56.6/54.6)	1.88 (47.8)	.312/.310 SQ. KEY x LG. 1.25/1.22 (31.8/31.0)
09 or 10	SAE 32-1 LONG (SAE-C)	3.36/3.28 (85.3/83.3)	3.01 (76.4)	.312/.310 SQ. KEY x LG. 2.38/2.35 (60.4/59.7)

SHAFT DESIGNATION PUMP MODEL CODE	SAE INVOLUTE SPLINE J498-B 1969 EXTERNAL CLASS 1 FLAT ROOT 12/24 DIA. PITCH 30° PRESSURE ANGLE 14 TEETH 1.2293-1.2243 MAJOR DIA (31.224/31.097)	SIDE FIT
03 or 08		

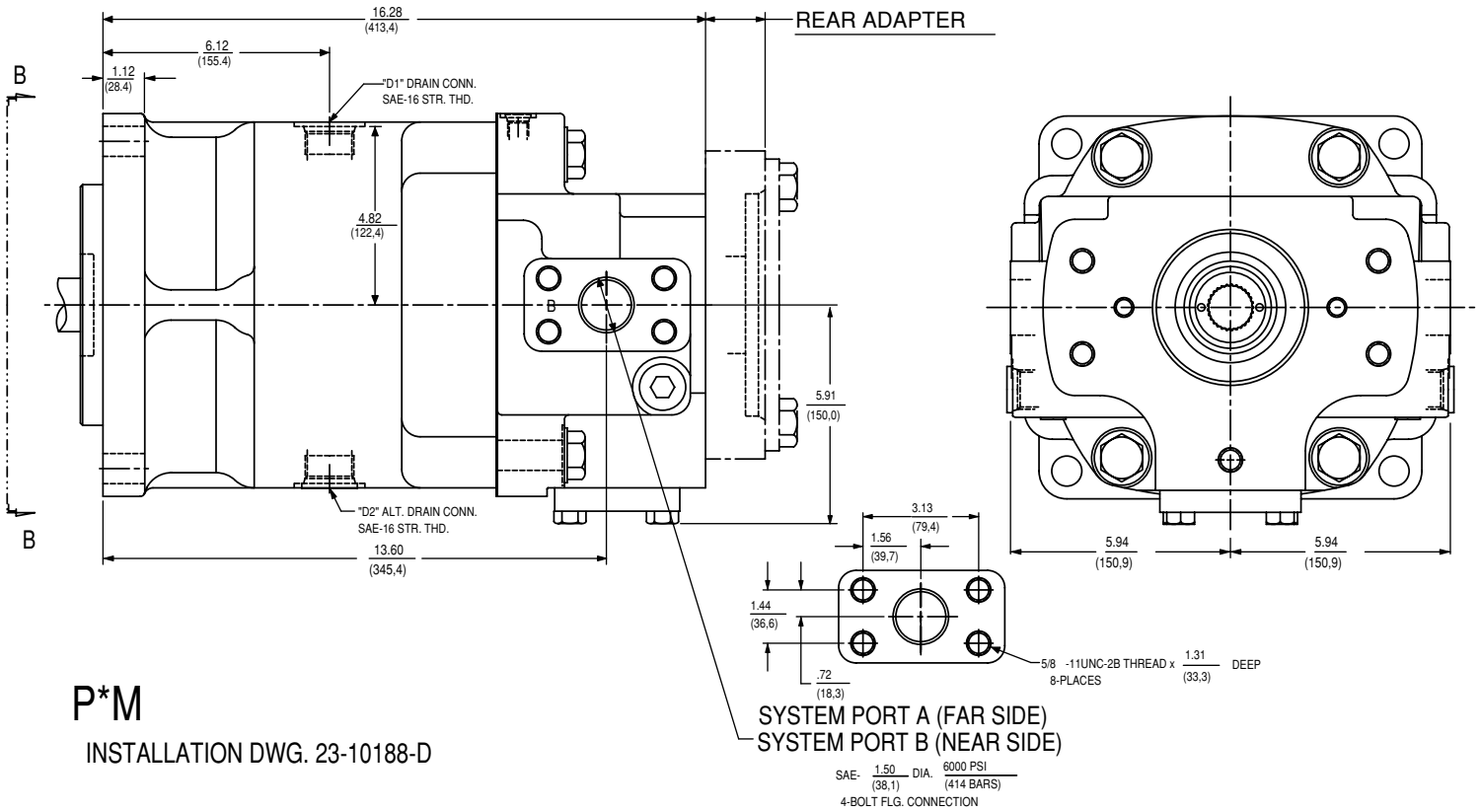

P*F
INSTALLATION DWG. 23-7957-D

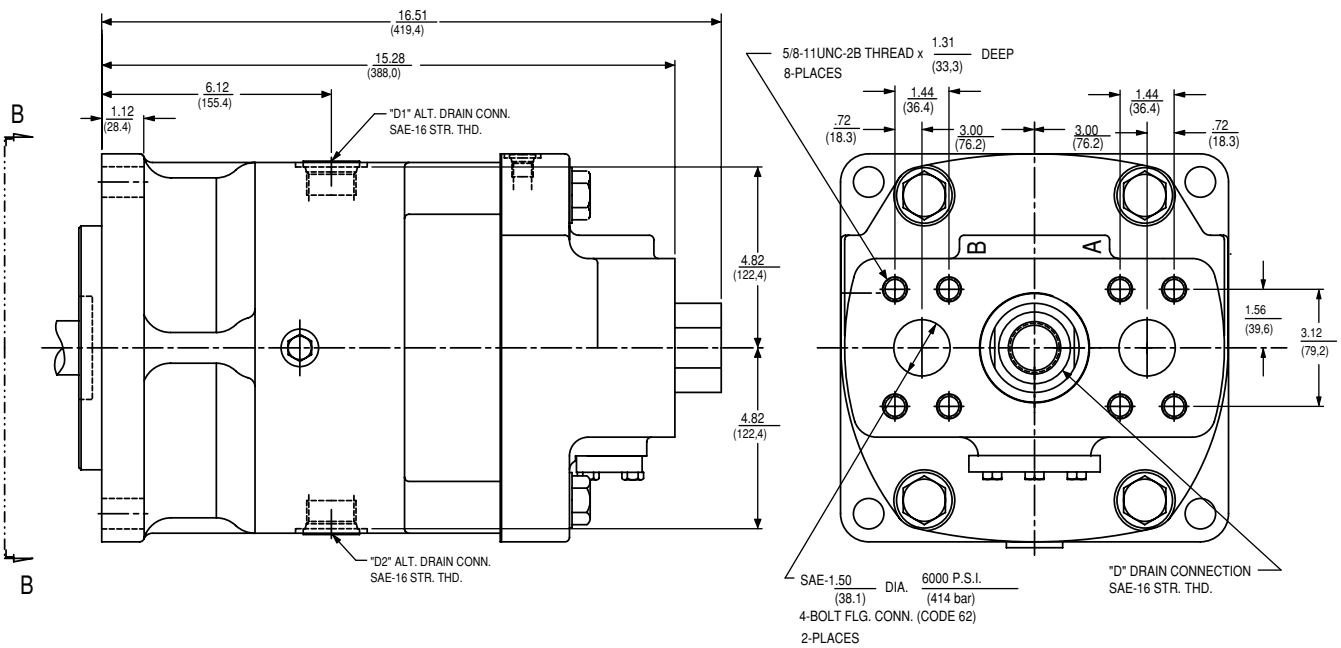

NOTE: See page 23 for shaft information.
See pages 45-53 for rear drive information.

P11-P14 P, V DIMENSIONS (LESS CONTROLS)

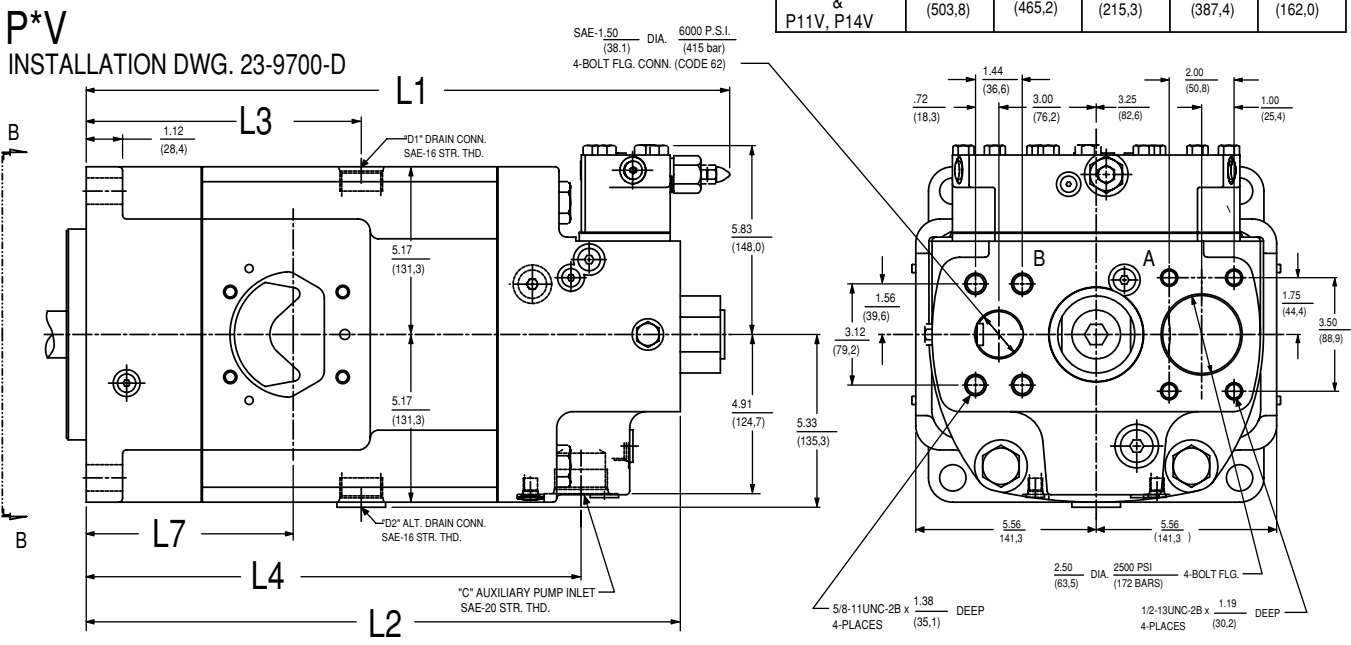
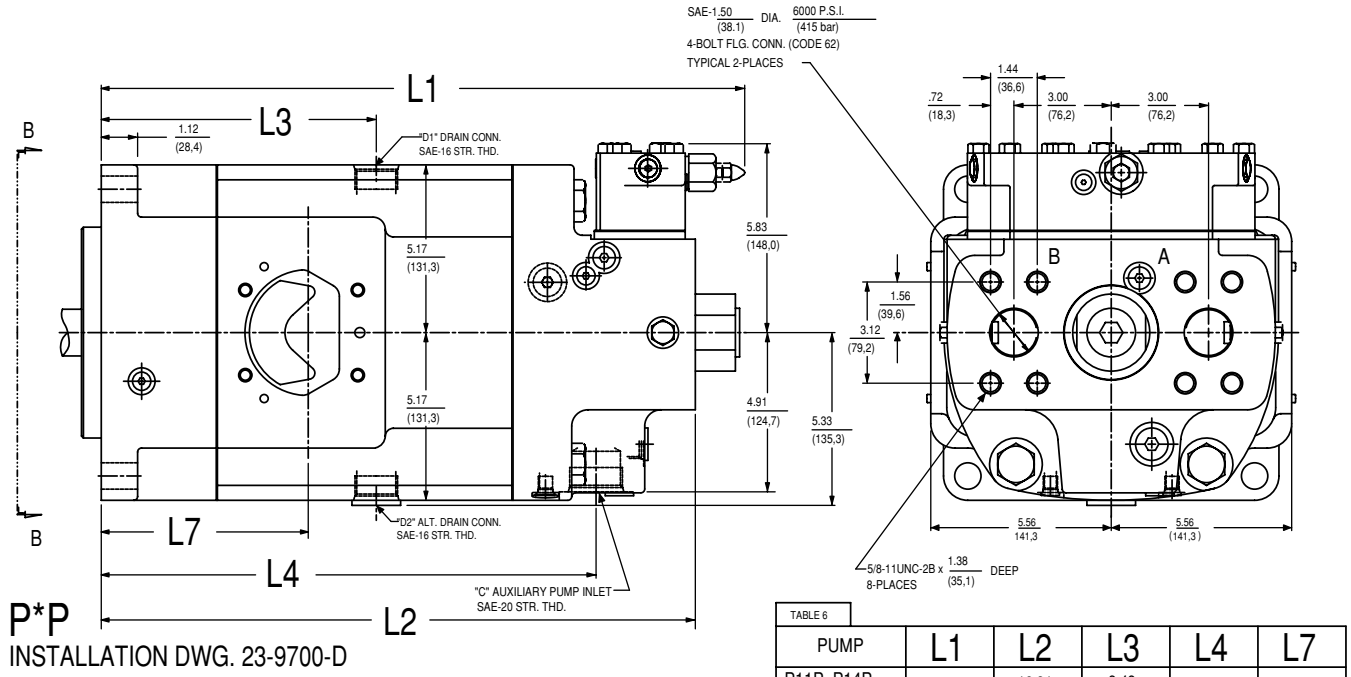

NOTE: See page 23 for shaft information.
See appropriate controls mounting starting on page 34.

P11-P14 S, X DIMENSIONS (LESS CONTROLS)

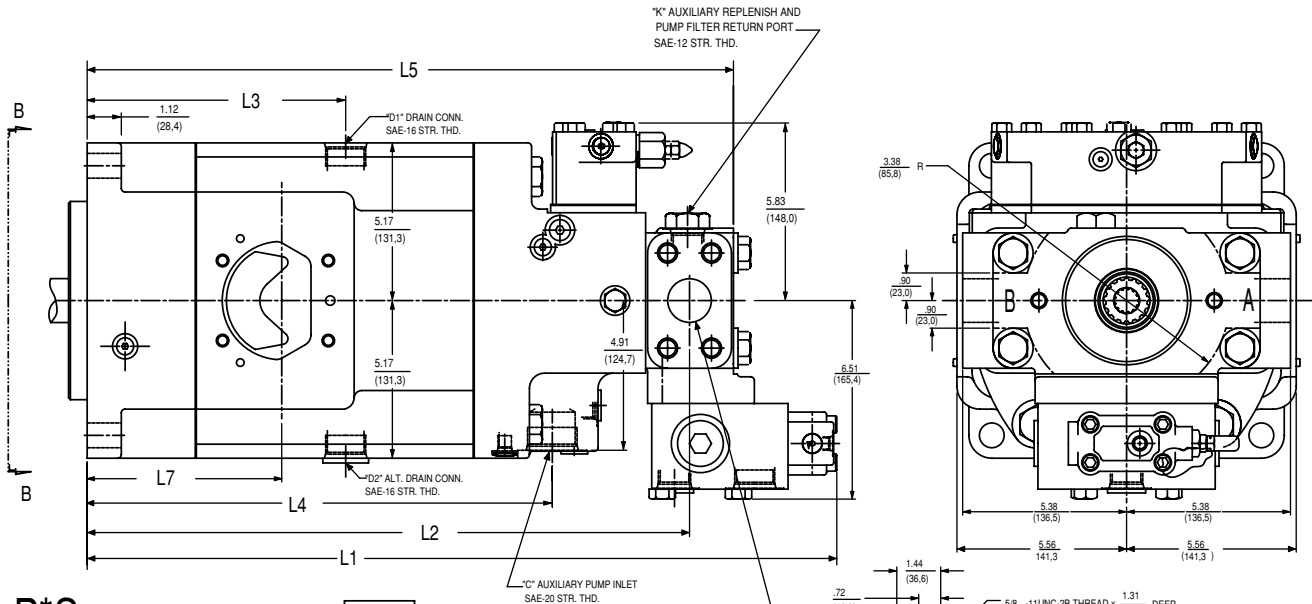

P*S
INSTALLATION DWG. 23-9861-D

TABLE 7		L1	L2	L3	L4	L5	L7
PUMP							
P*S	24.58 (624.4)	19.75 (501.7)	8.48 (215.3)	15.25 (387.4)	21.19 (538.3)	6.38 (162.0)	
P*X	21.88 (555.7)						

P*X
INSTALLATION DWG. 23-9861-D

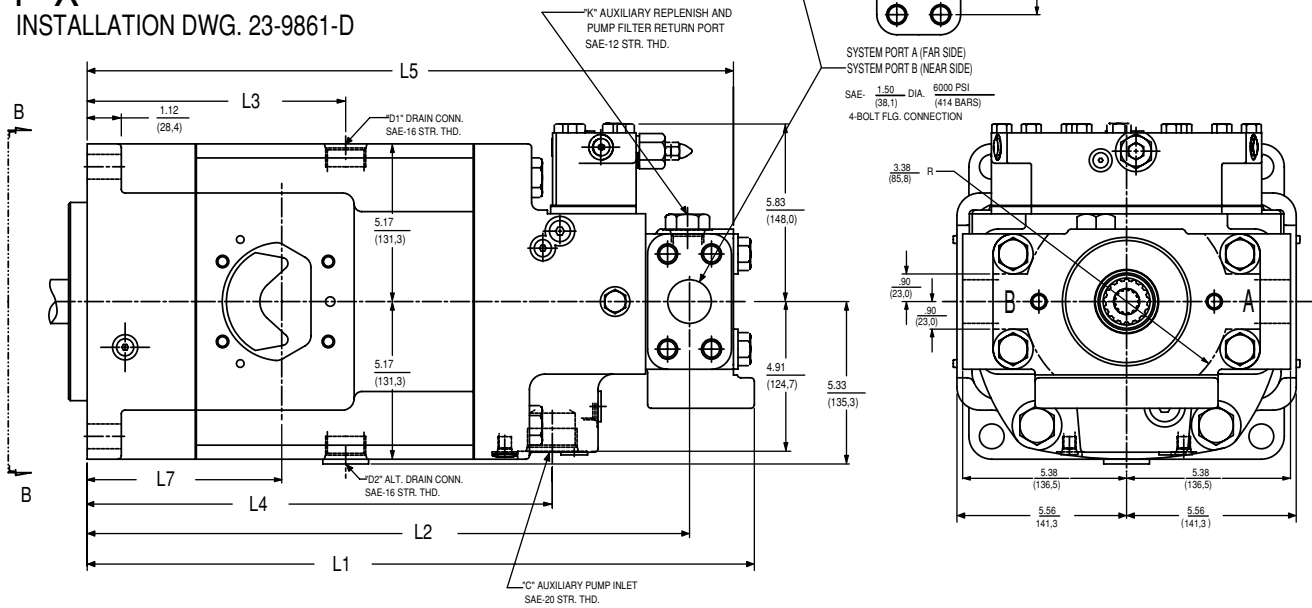

NOTE: See page 23 for shaft information.
See pages 45-53 for rear drive information.
See appropriate controls mounting starting on page 34.

P11-P14 R, L DIMENSIONS
(LESS CONTROLS)

P*R & P*L

INSTALLATION DWG. 23-10097-D

TABLE 8					
PUMP	L1	L2	L3	L4	L7
P*R & P*L	18.31 (465,2)	15.64 (397,1)	8.48 (215,3)	18.31 (465,2)	6.38 (162,0)

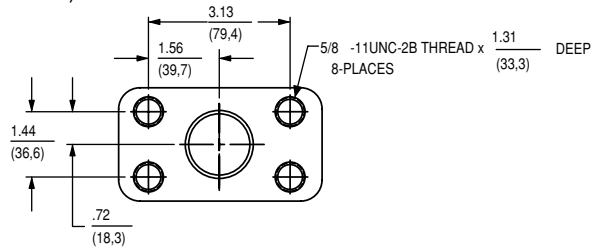

SYSTEM PORT A (FAR SIDE)
SYSTEM PORT B (NEAR SIDE)

SAE- 1.50 DIA. 6000 PSI
(38,1) (414 BARS)
4-BOLT FLG. CONNECTION

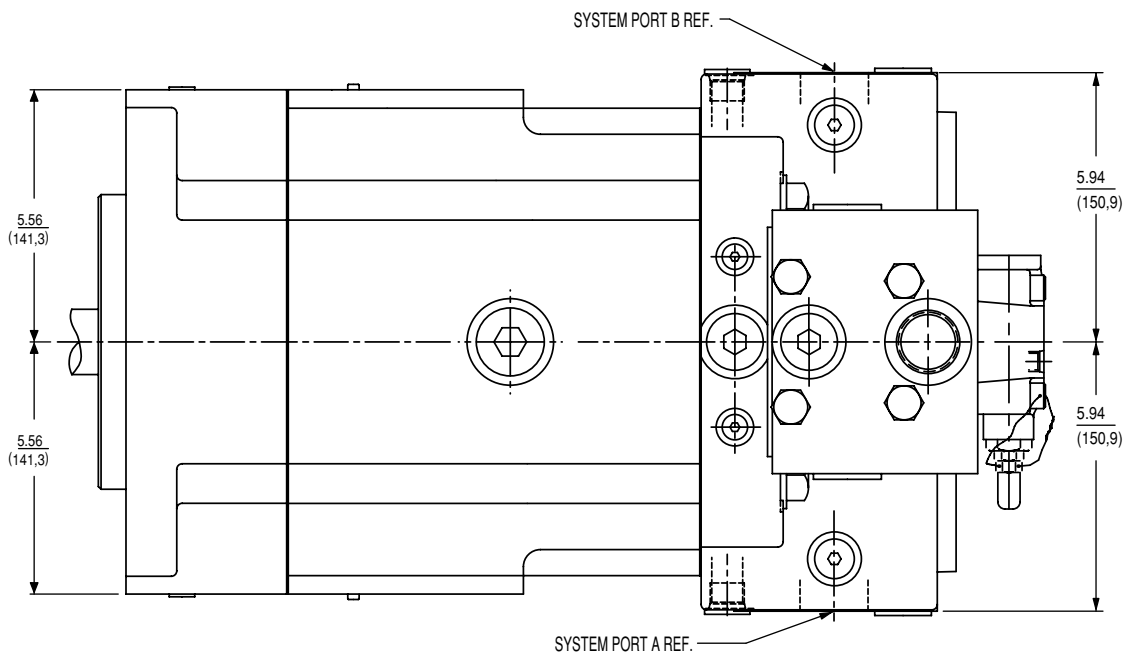
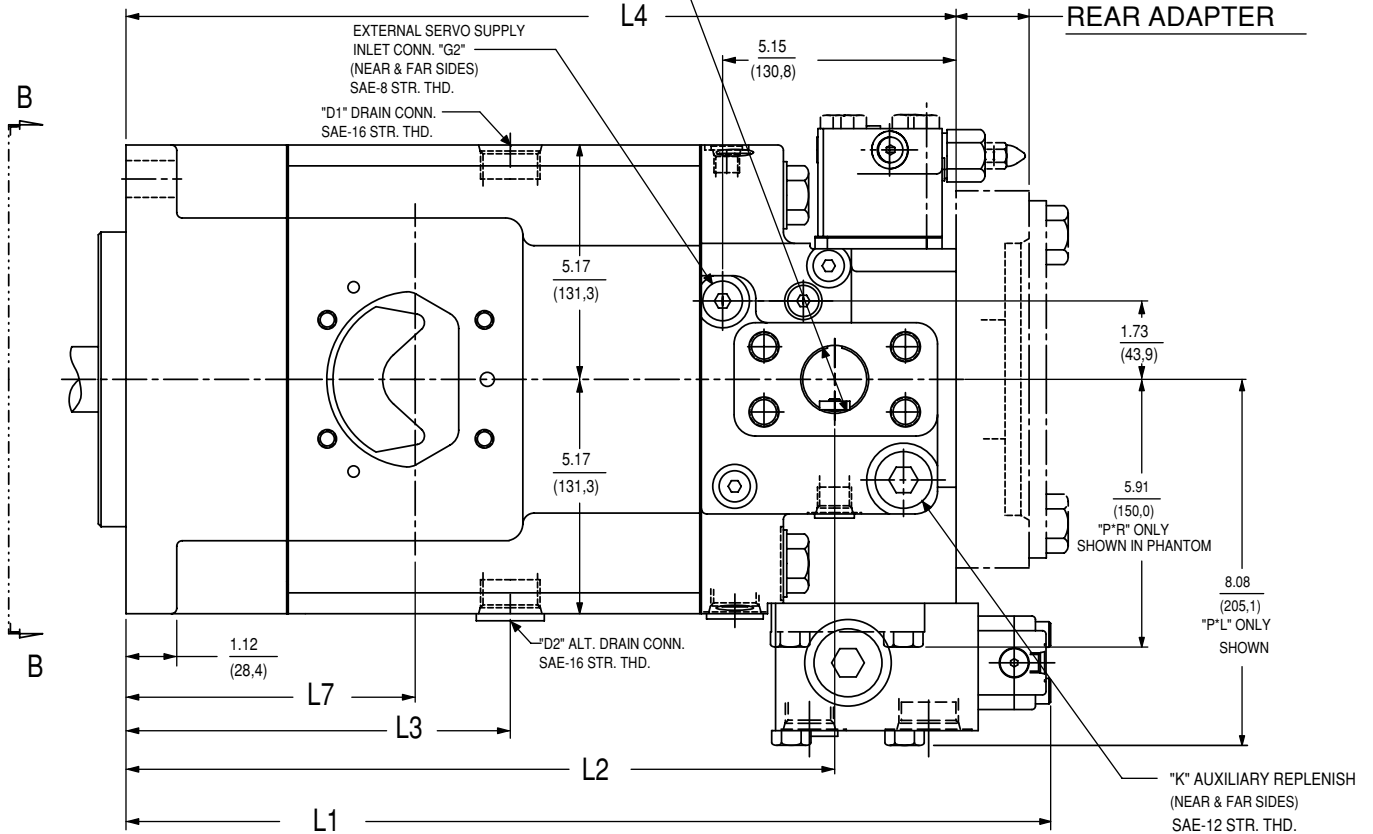

NOTE: See page 23 for shaft information.
See pages 45-53 for rear drive information.
See appropriate controls mounting starting on page 34.

**M11-M14 H, V, F, G DIMENSIONS
(LESS CONTROLS)**

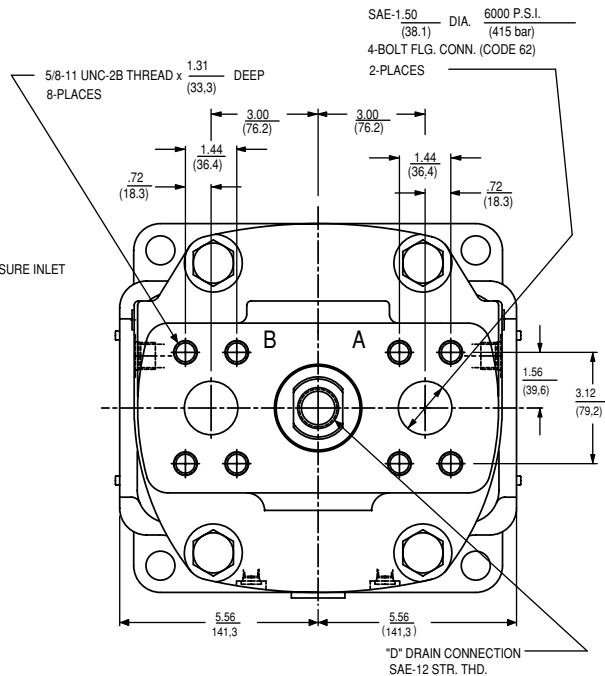
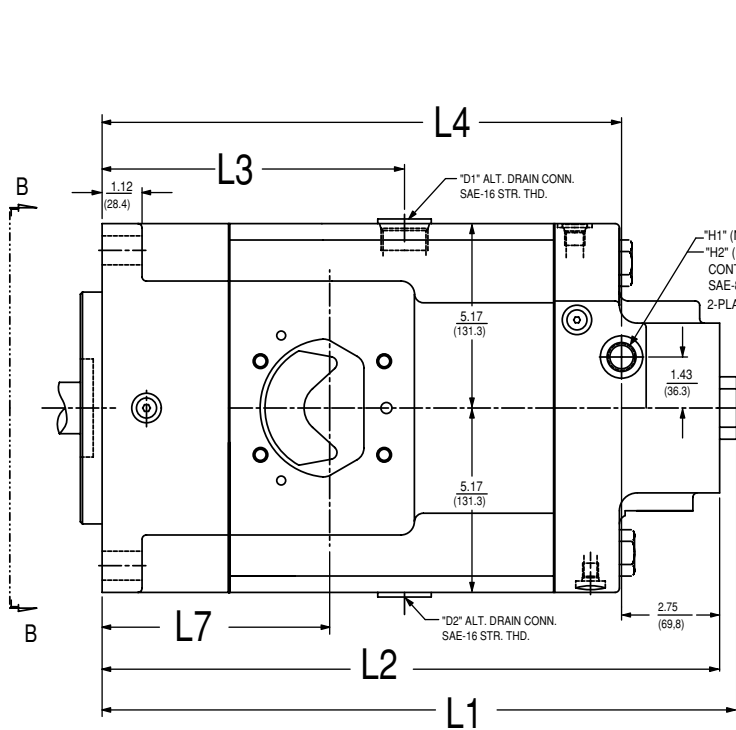

TABLE 15

MOTOR	L1	L2	L3	L4	L7
M11H, M11V & M14H, M14V	17.79 (451.9)	17.32 (439.9)	8.48 (215.3)	14.56 (369.9)	6.38 (162.0)

M*H & M*V

INSTALLATION DWG. 23-9900-D

M*F & M*G

INSTALLATION DWG. 23-7957-D

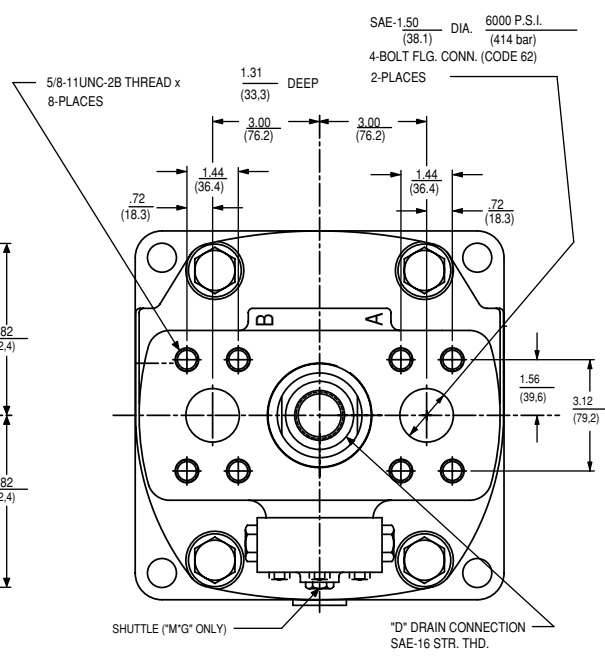
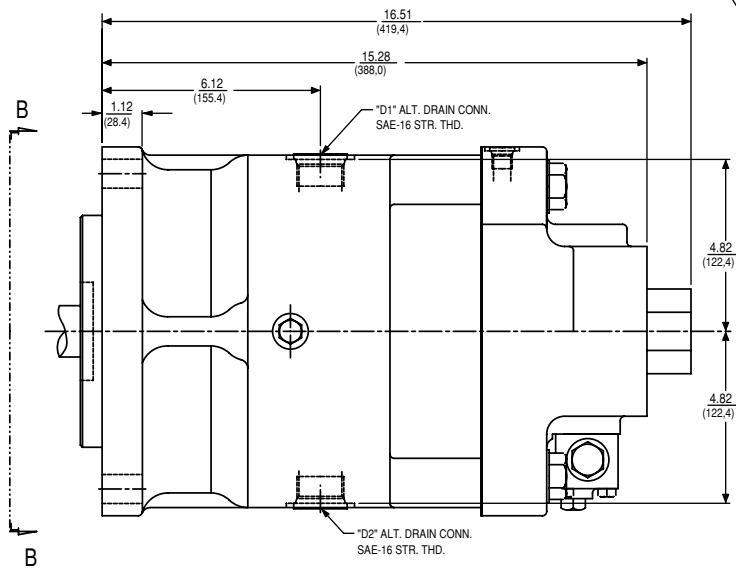

NOTE: See page 23 for shaft information.
See appropriate controls mounting starting on page 34.

**M11-M14 M, N, R, L DIMENSIONS
(LESS CONTROLS)**

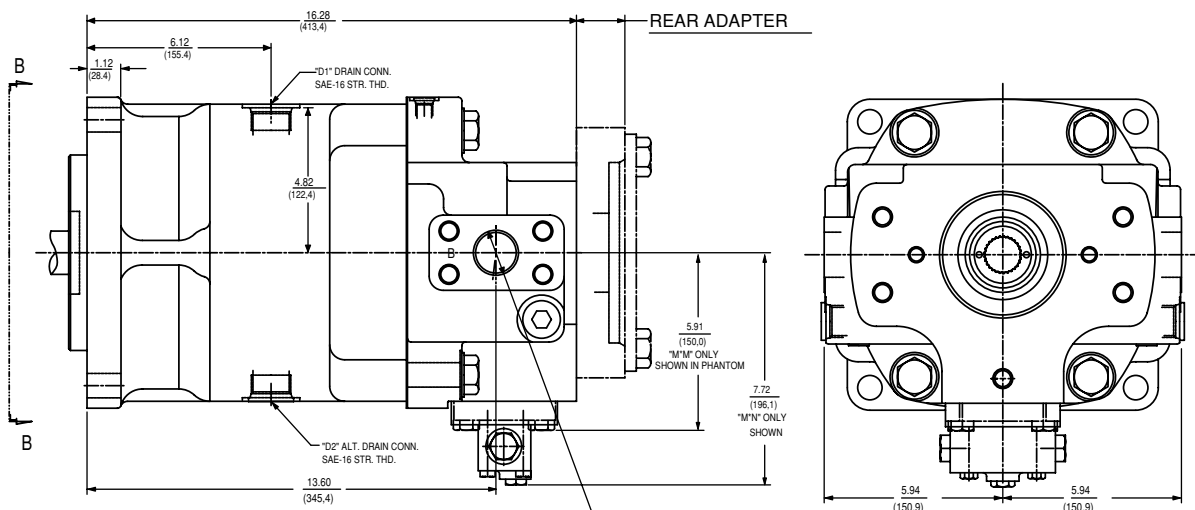

M*M & M*N
INSTALLATION DWG. 23-10188-D

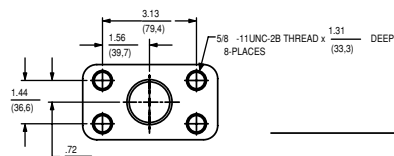

SYSTEM PORT A (FAR SIDE)
SYSTEM PORT B (NEAR SIDE)

SAE- 1.50 DIA. 5000 PSI
(38.1) (414 BARS)

M*R & M*L
INSTALLATION DWG. 23-10330-D

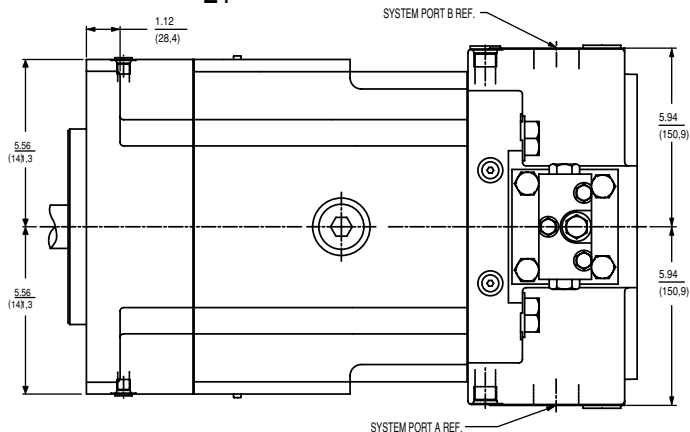
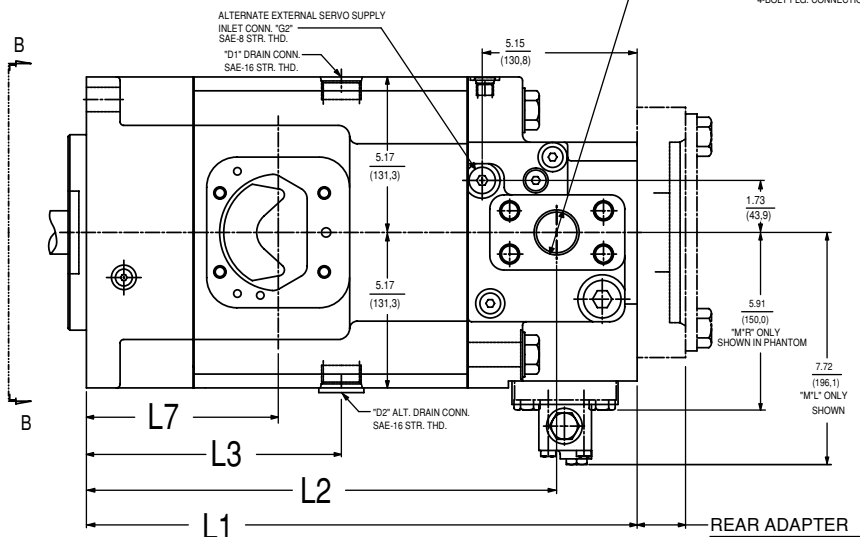

MOTOR	L1	L2	L3	L4	L7
M11R, M11L & M14R, M14L	18.31 (465.2)	15.64 (397.1)	8.48 (215.3)	14.56 (369.9)	6.38 (162.0)

NOTE: See page 23 for shaft information.
See pages 45-53 for rear drive information.
See appropriate controls mounting starting on page 34.

M*F, M*G, M*H, M*V, P*S, P*X, P*P, P*V & P*F M*R, M*L, M*M, M*N, P*L & P*R

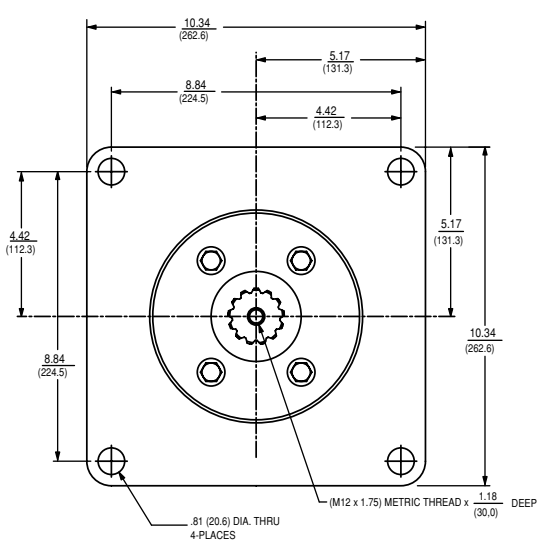

VIEW B-B

NOTES:

- SPLINE LENGTH AND NECK ONLY FOR:
M*F, M*G, M*H, M*V, P*S, P*X, P*P, P*V & P*F
- SPLINE LENGTH ONLY FOR:
M*R, M*L, M*M, M*N, P*L & P*R

SHAFT DESIGNATION PUMP MODEL CODE	SAE INVOLUTE SPLINE DATA, J496B 1969 FLAT ROOT SIDE FIT EXTERNAL CLASS 1 8/16 PITCH 30° PRESSURE ANGLE 13 TEETH 1.7210-1.7160 MAJOR DIA. (43,713-43,586)
03 or 08	

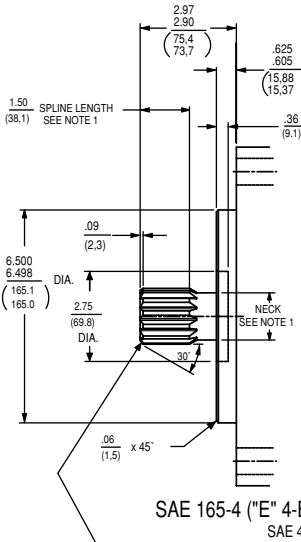

SAE 165-4 ("E" 4-BOLT)
SAE 44-4
("E" SPLINE)

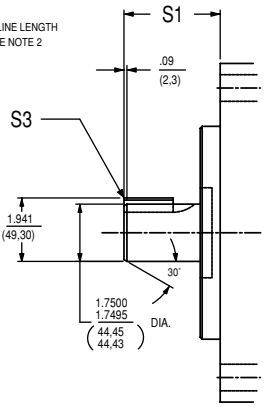
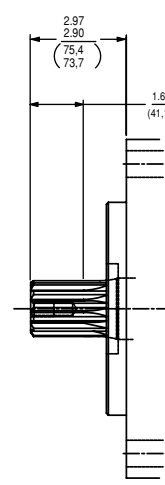

SAE 165-4 ("E" 4-BOLT)
SAE 44-1
("E" KEYED)

SHAFT DESIGNATION PUMP MODEL CODE	SHAFT	S1		S3	
		2.97/2.90 (75.4/73.7)	.437/.435 (11.10/11.05)	SQ. KEY x LG. 1.50 (38.1)	2.50 (63.5)
02 or 07	SAE 44-1 (SAE-E)				
09 or 10	SAE 44-1 LONG (SAE-E)	3.97/3.90 (100.8/99.1)	.437/.435 (11.10/11.05)		

**P24-P30 P DIMENSIONS
(LESS CONTROLS)**

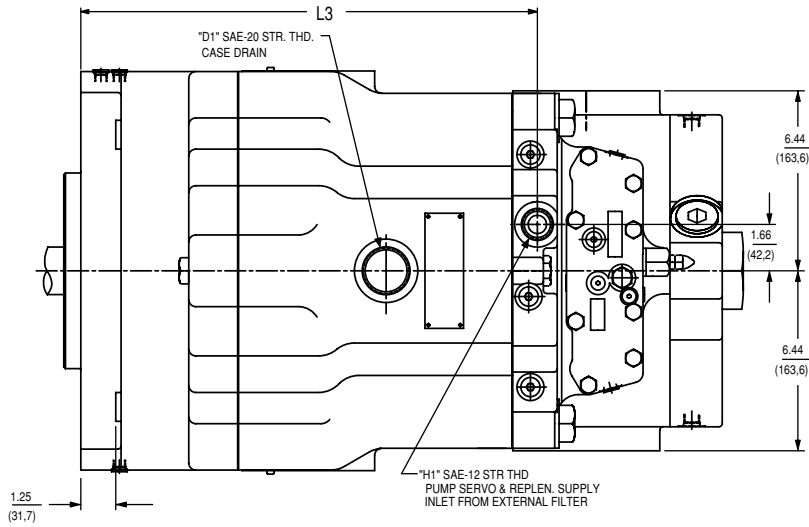

PUMP	L1	L2	L3	L4	L7
P24P (SHOWN)	23.70 (602.1)	18.08 (459.4)	16.34 (414.9)	18.80 (477.4)	8.14 (206.7)
P30P	24.70 (627.5)	19.08 (484.7)	17.34 (440.3)	19.80 (502.8)	

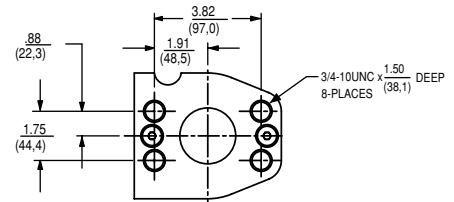

SYSTEM PORT A (FAR SIDE)
SYSTEM PORT B (NEAR SIDE)
SAE- 2.00 DIA. 6000 PSI
(50.8) (414 bar)
4-BOLT FLG. CONN

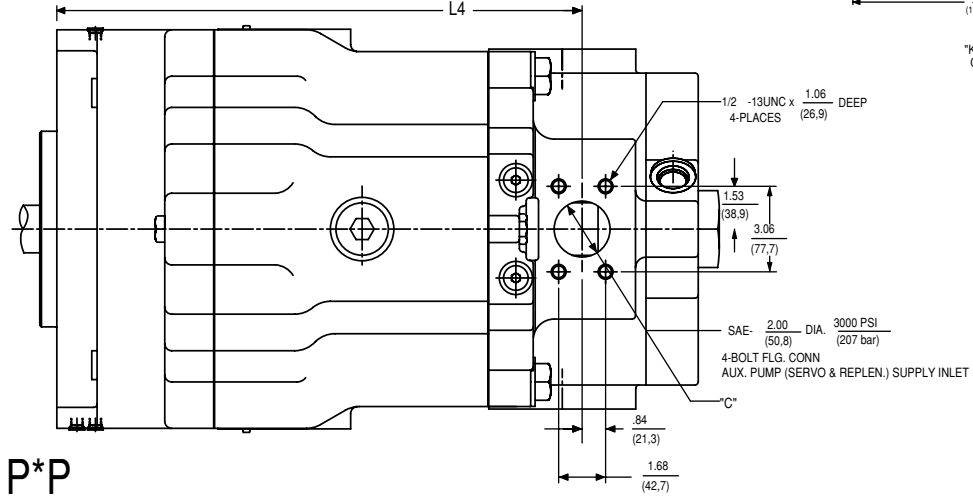
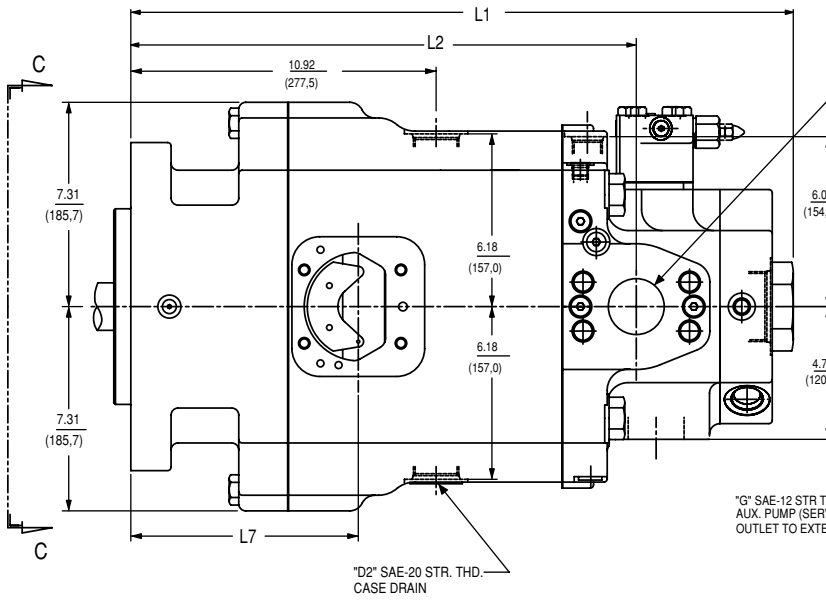
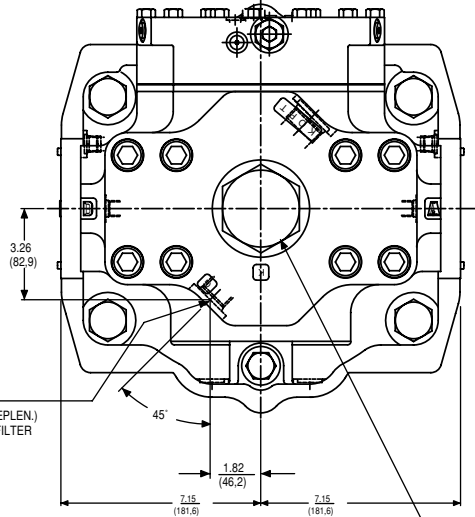

P*P
INSTALLATION DWG. 23-9922-D (P24P)
INSTALLATION DWG. 23-9913-D (P30P)

NOTE: See page 32 for shaft information.
See appropriate controls mounting starting on page 34.

**P24-P30 X DIMENSIONS
(LESS CONTROLS)**

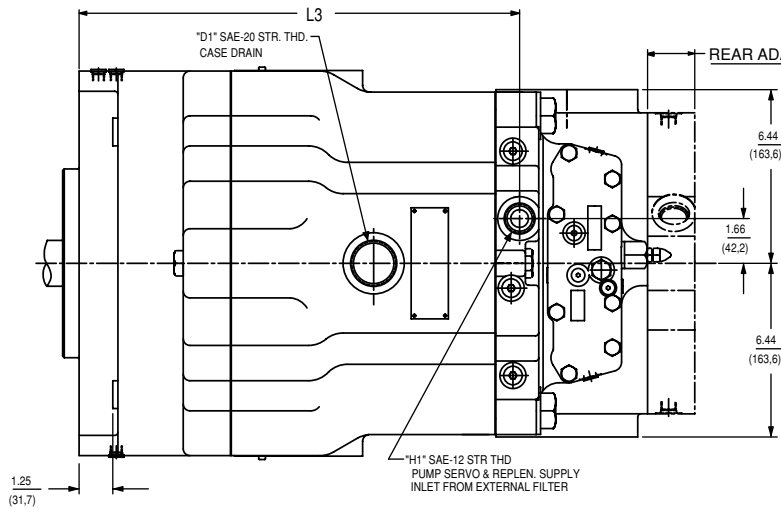
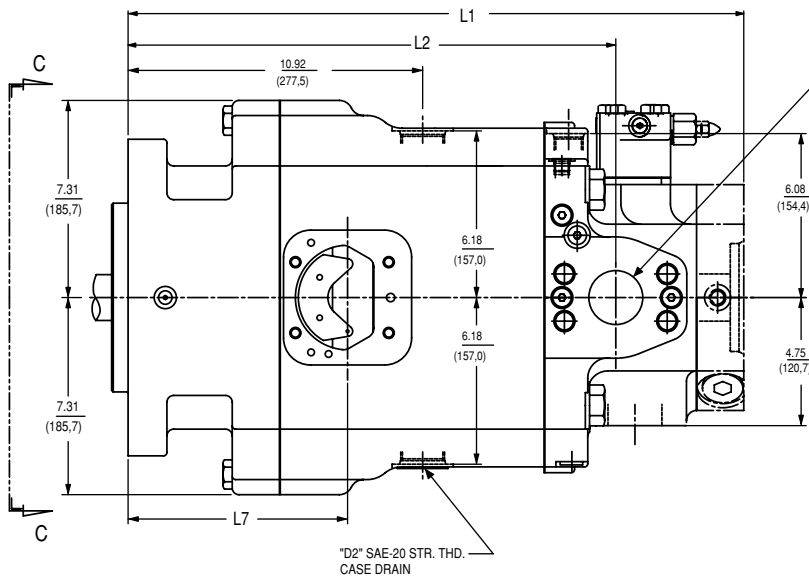
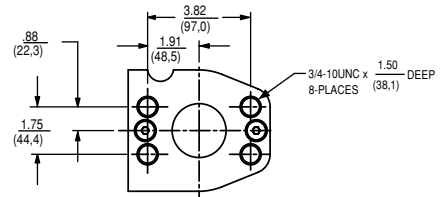
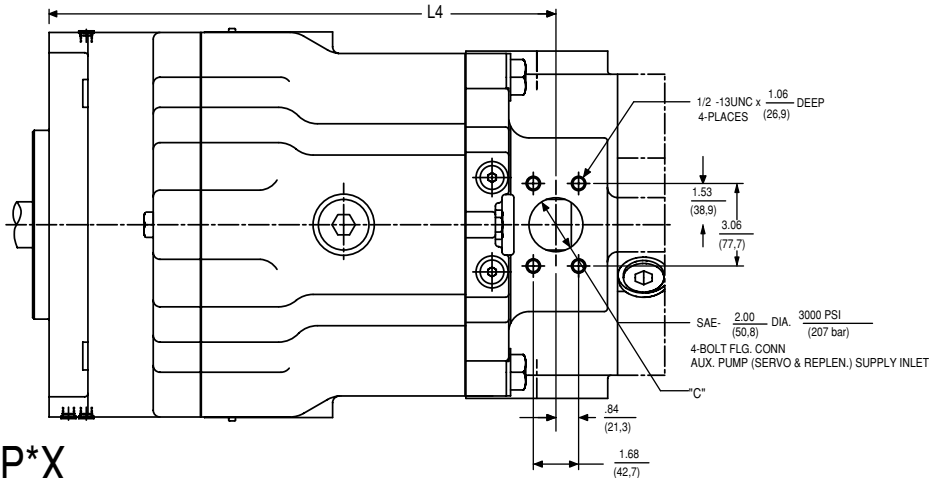
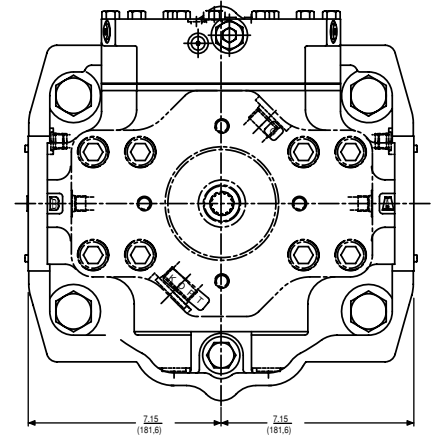

TABLE 11

PUMP	L1	L2	L3	L4	L7
P24X (SHOWN)	22.83 (579.9)	18.08 (459.4)	16.34 (414.9)	18.80 (477.4)	8.14 (206.7)
P30X	23.83 (605.3)	19.08 (484.7)	17.34 (440.3)	19.80 (502.8)	



SYSTEM PORT A (FAR SIDE)
SYSTEM PORT B (NEAR SIDE)
SAE- 2.00 DIA. 6000 PSI
(50.8) (414 bar)
4-BOLT FLG. CONN



P*X
INSTALLATION DWG. 23-10368-D

NOTE: See page 32 for shaft information.
See pages 45-53 for rear drive information.
See appropriate controls mounting starting on page 34.

**P24-P30 S DIMENSIONS
(LESS CONTROLS)**

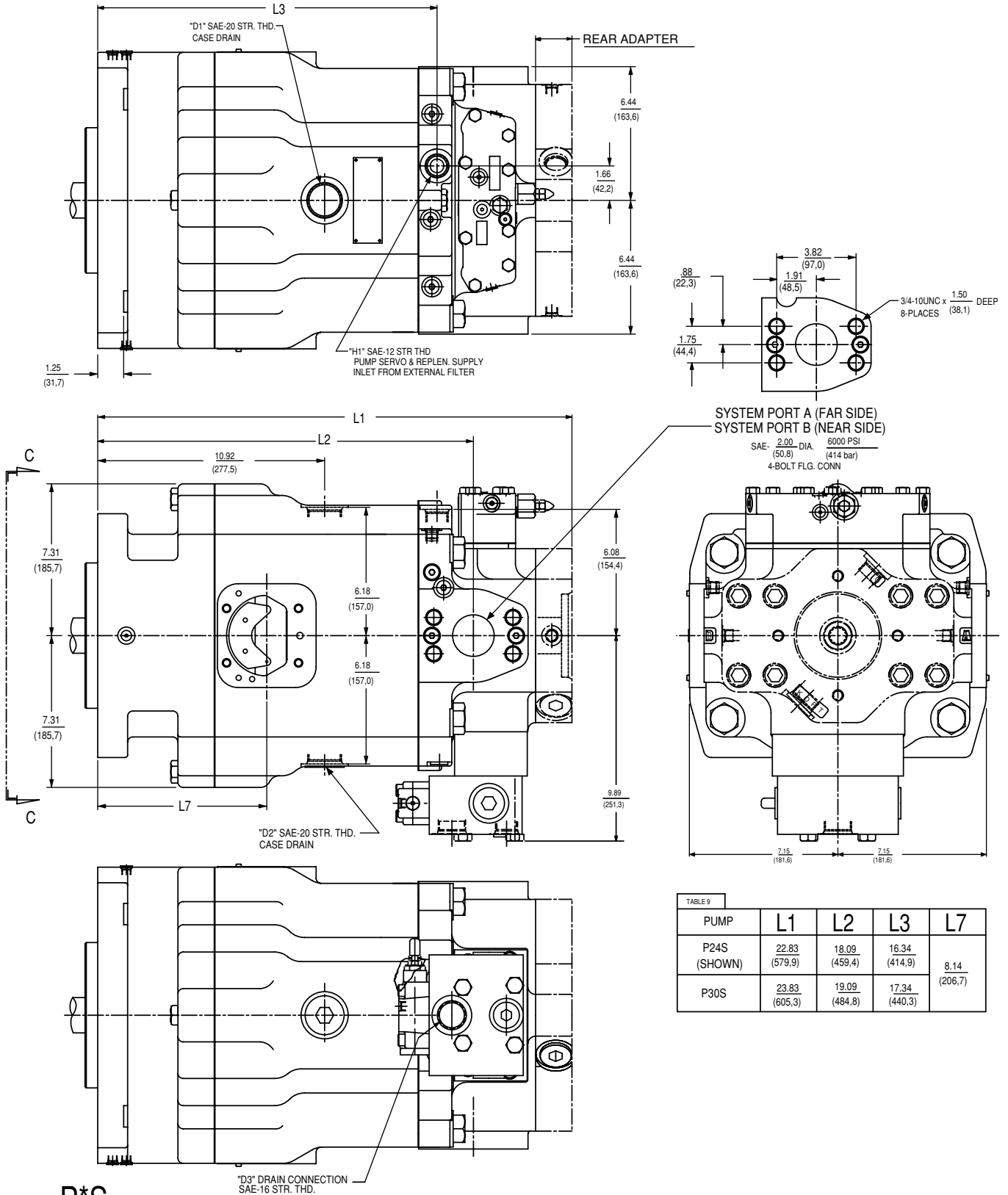
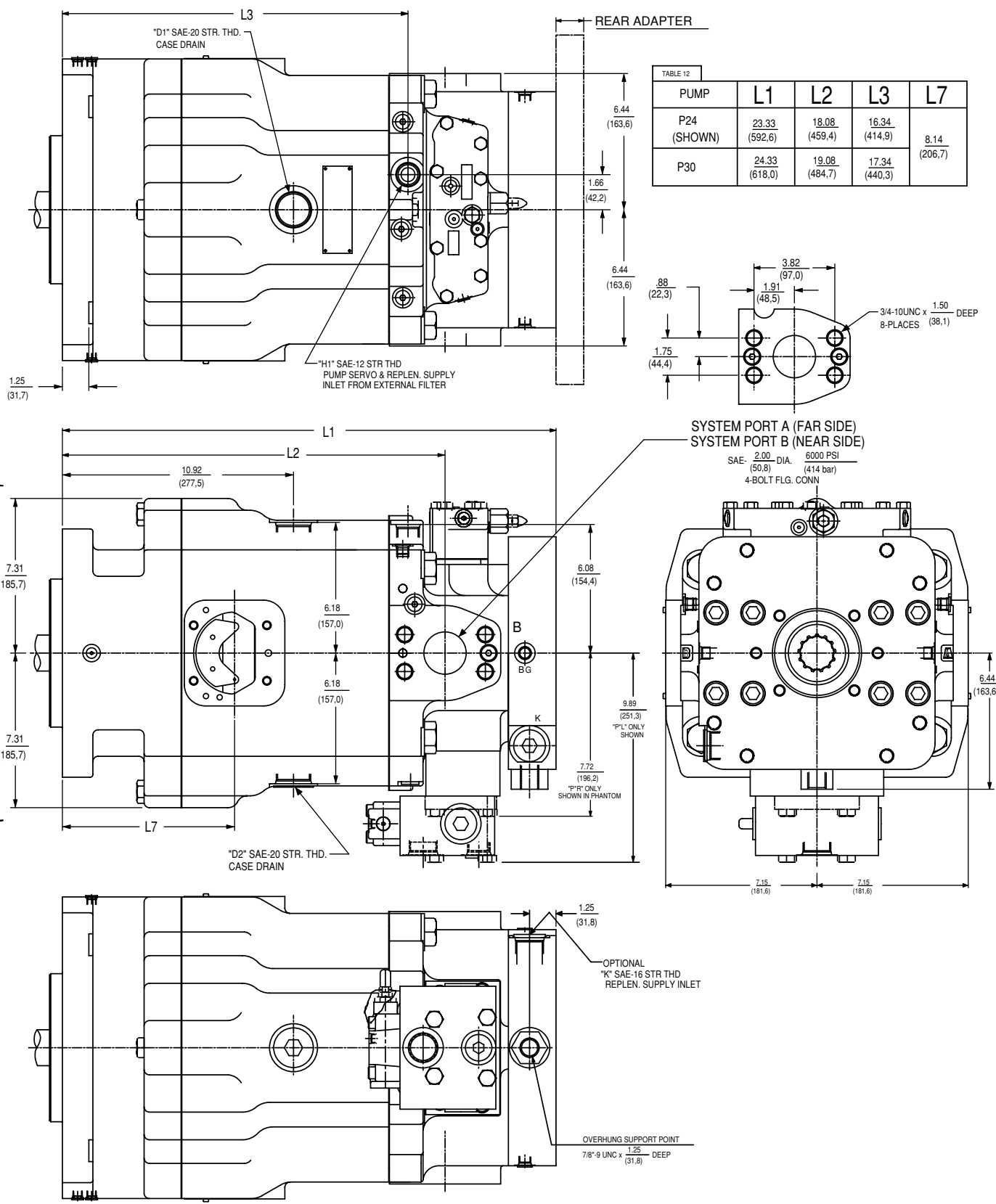

TABLE 9				
PUMP	L1	L2	L3	L7
P24S (SHOWN)	22.83 (579.9)	18.09 (459.4)	16.34 (414.9)	8.14 (206.7)
P30S	23.83 (605.3)	19.09 (484.8)	17.34 (440.3)	

P*S
INSTALLATION DWG. 23-10285-D

NOTE: See page 32 for shaft information.
See pages 45-53 for rear drive information.
See appropriate controls mounting starting on page 34.

**P24-P30 R, L DIMENSIONS
(LESS CONTROLS)**



P*R & P*L
INSTALLATION DWG. 23-10112-D

NOTE: See page 32 for shaft information.
See pages 45-53 for rear drive information.
See appropriate controls mounting starting on page 34.

**M24-M30 H, V, F, G DIMENSIONS
(LESS CONTROLS)**

24-30 MOTOR DIMENSIONS
(LESS CONTROLS)

M*H & M*V

INSTALLATION DWG. 23-9818-D (M24)

INSTALLATION DWG. 23-9765-D (M30)

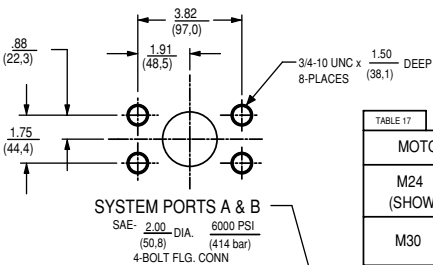
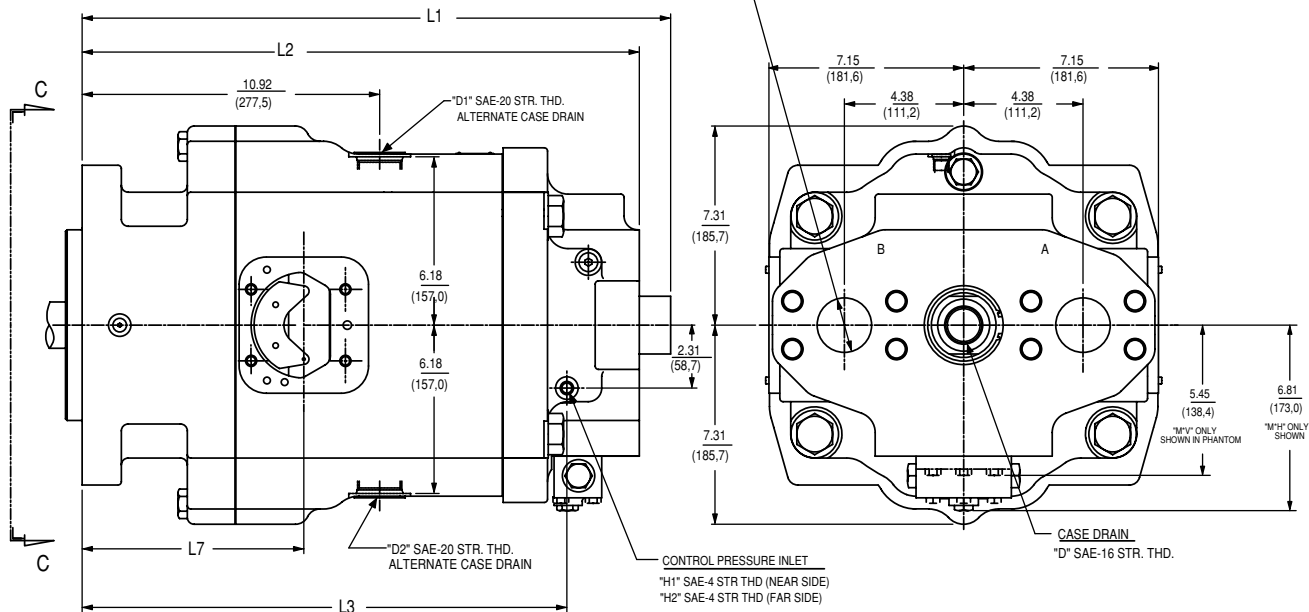

TABLE 17				
MOTOR	L1	L2	L3	L7
M24 (SHOWN)	21.61 (548.8)	20.46 (519.6)	17.80 (452.0)	8.14 (206.7)
M30	22.61 (574.2)	21.46 (545.0)	18.80 (477.4)	



M*F & M*G

INSTALLATION DWG. 23-9825-D (M24)

INSTALLATION DWG. 23-9764-D (M30)

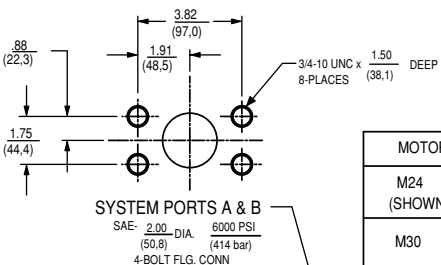

MOTOR	L1	L2
M24 (SHOWN)	21.61 (548.8)	20.46 (519.6)
M30	22.61 (574.2)	21.46 (545.0)

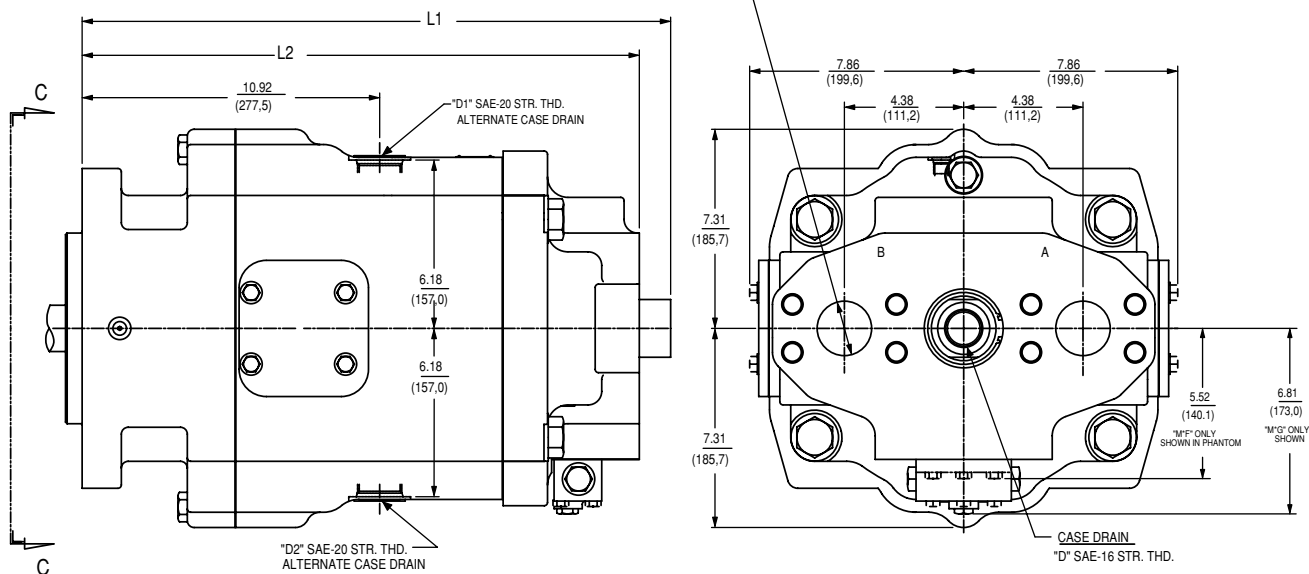

NOTE: See page 32 for shaft information.

See appropriate controls mounting starting on page 34.

M*M & M*N

INSTALLATION DWG. 23-10206-D

PUMP	L1	L2
M24 (SHOWN)	23.33 (592.6)	18.09 (459.4)
M30	24.33 (618.0)	19.09 (484.8)

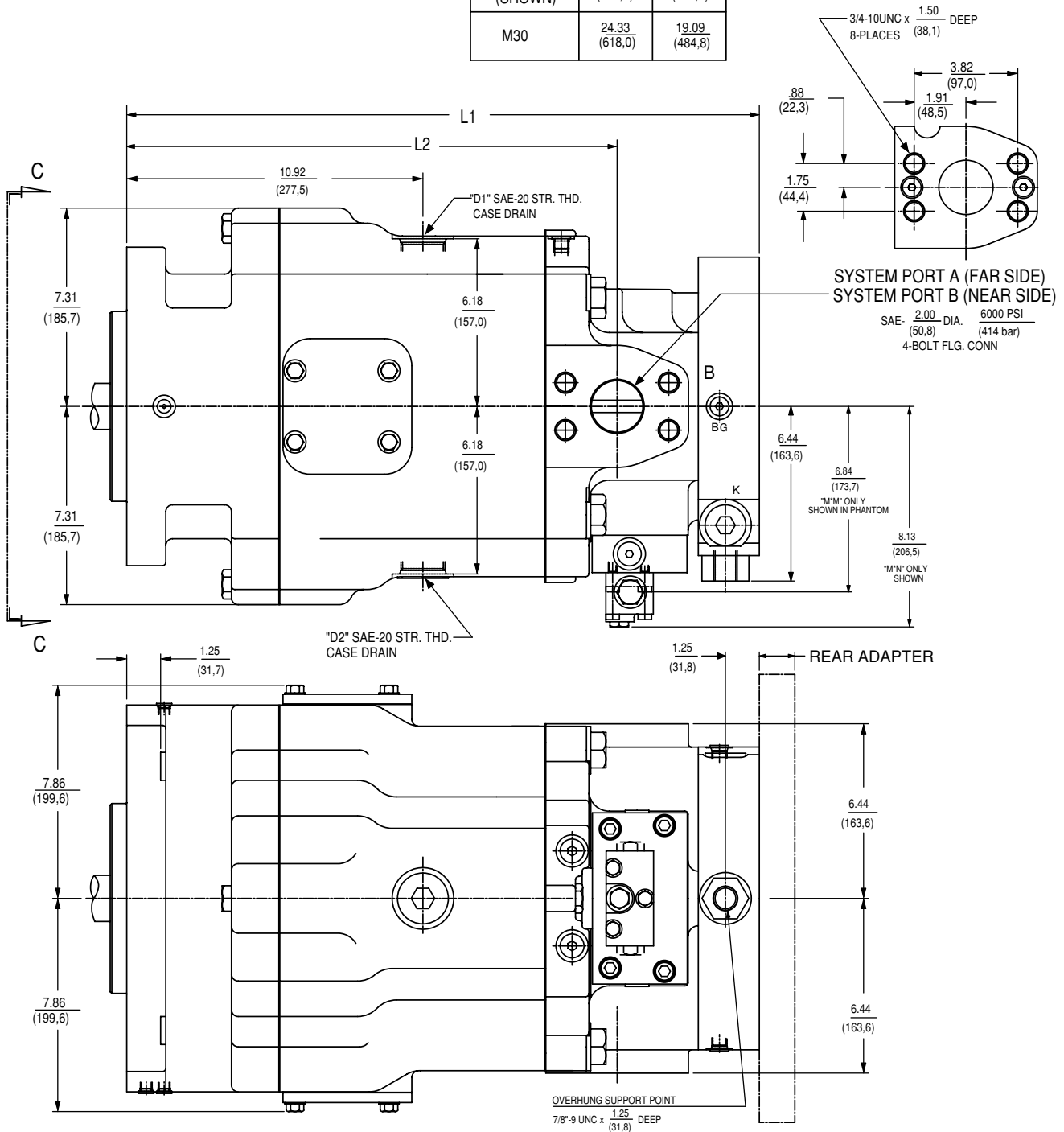

NOTE: See page 32 for shaft information.
See pages 45-53 for rear drive information.

M*R & M*L
INSTALLATION DWG. 23-10335-D

TABLE 18			
PUMP	L1	L2	L7
M24 (SHOWN)	23.33 (592,6)	18.09 (459,4)	8.14 (206,7)
M30	24.33 (618,0)	19.09 (484,8)	

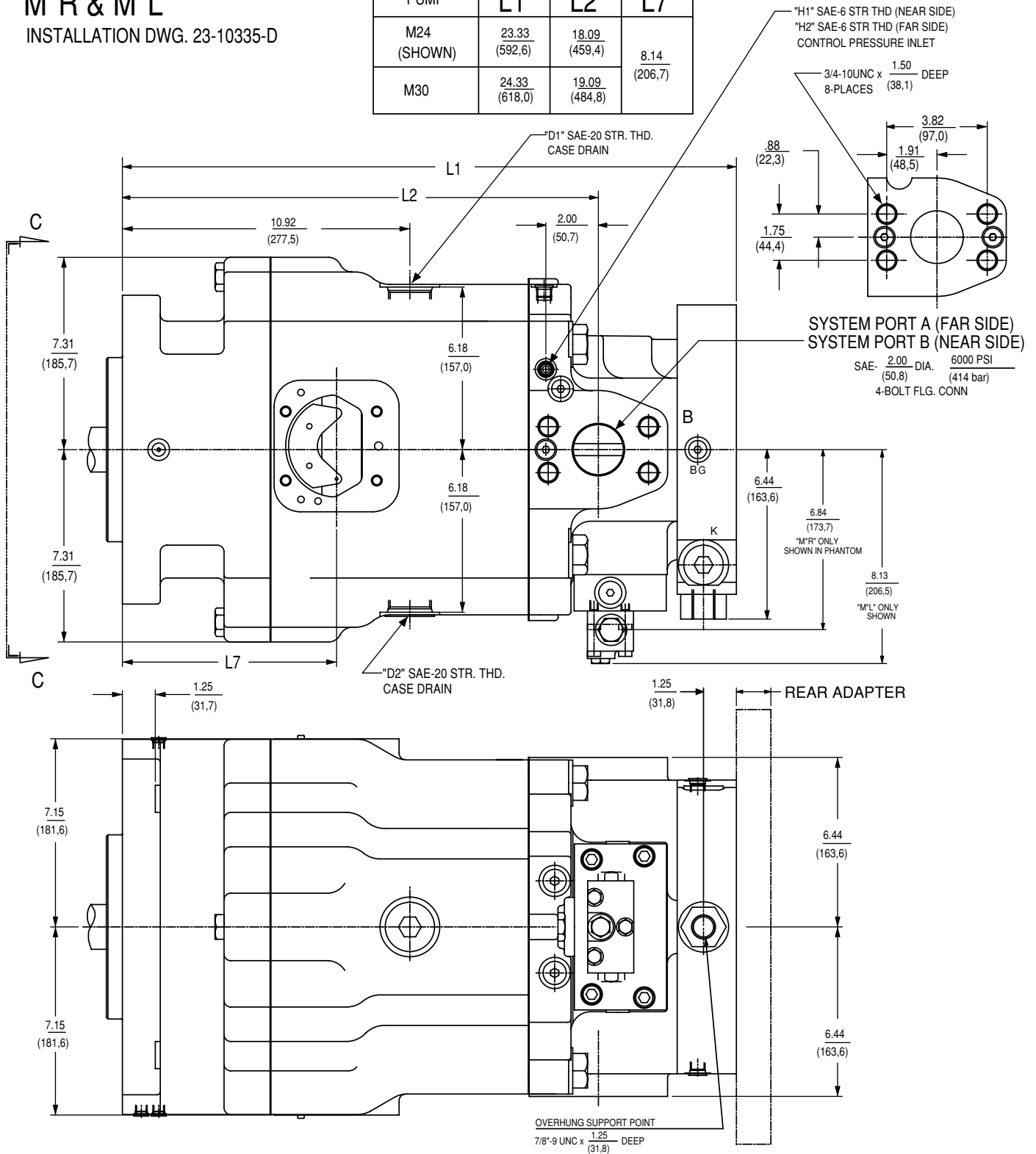

NOTE: See page 32 for shaft information.
See pages 45-53 for rear drive information.
See appropriate controls mounting starting on page 34.

M*F, M*G, M*H, M*V, P*S, P*X, P*P & P*F M*R, M*L, M*M, M*N, P*L & P*R

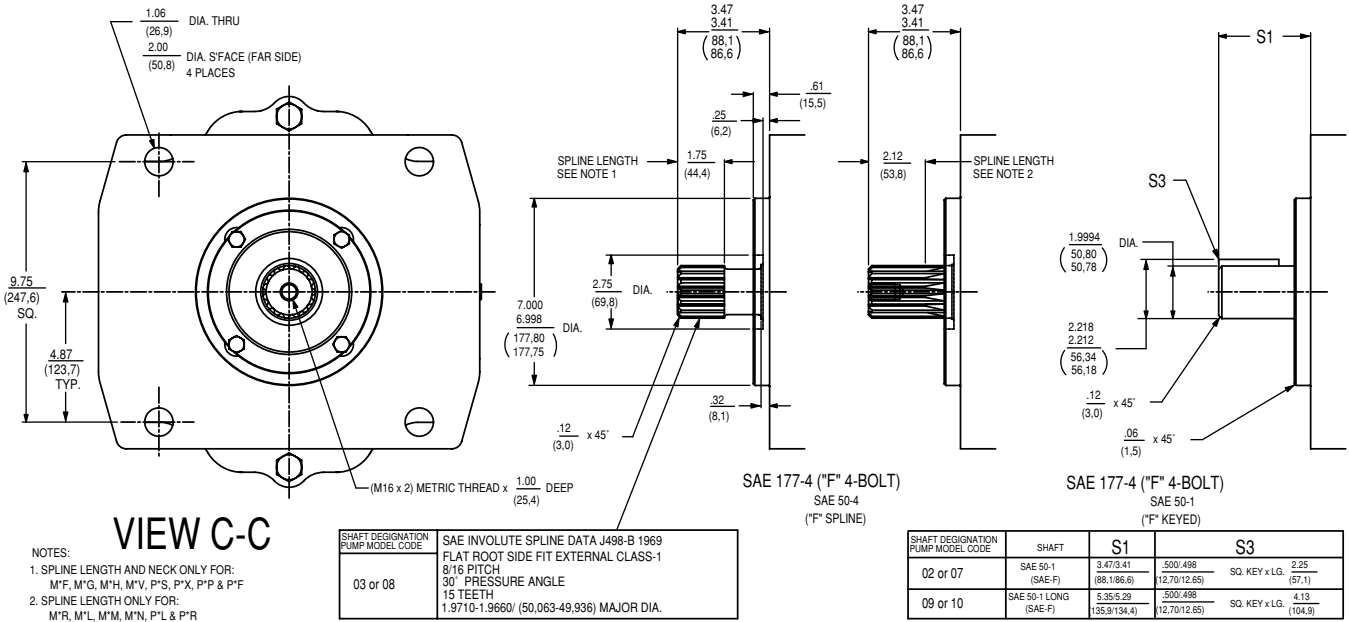

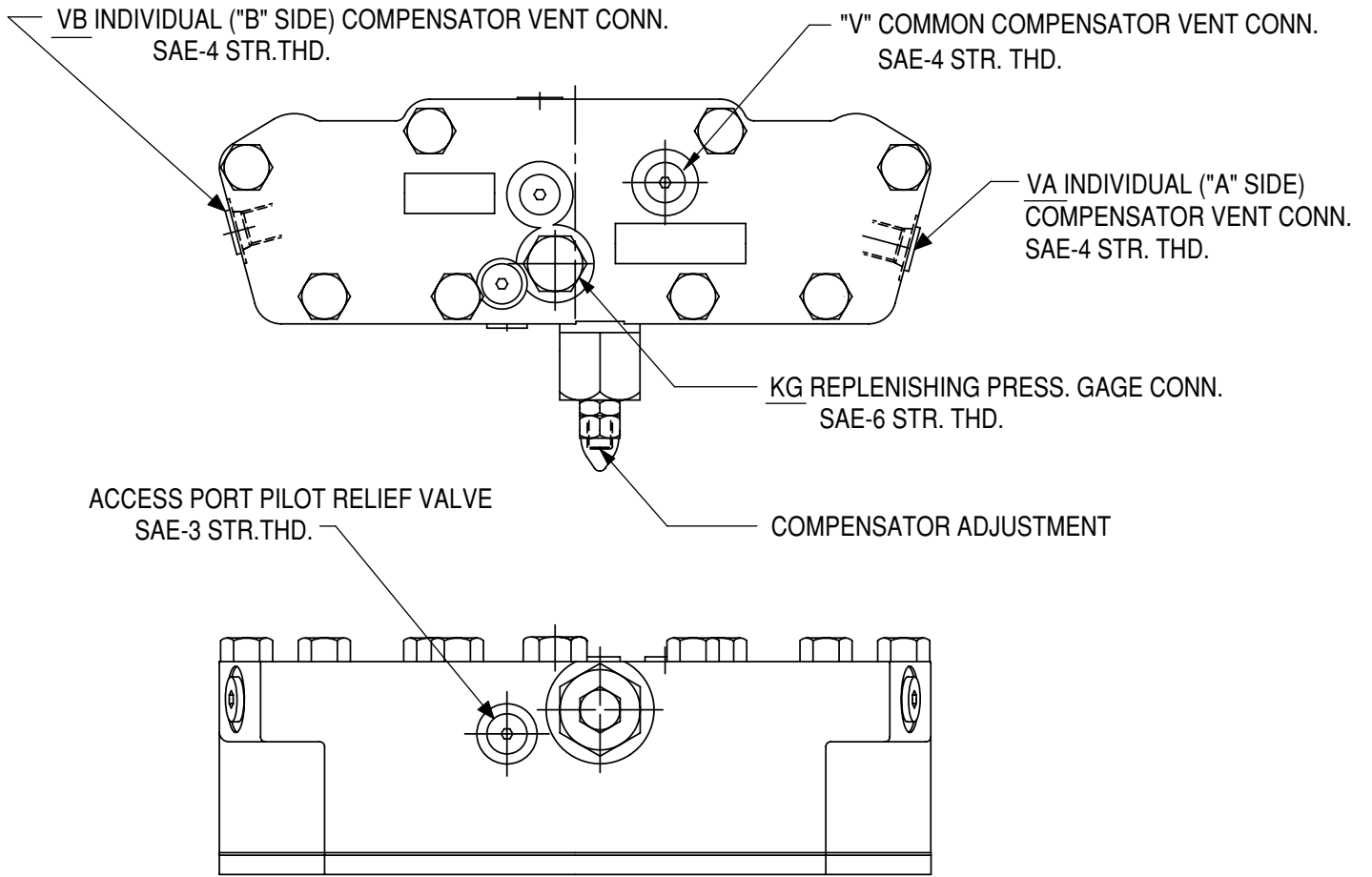

-B- CONTROL MTG. POSITION				
CONTROL OPTION	FIG.	PUMP ROT.	ROTARY SERVO INPUT SHAFT ROTATION	PORT "A"
"10"	1	CW	CCW	INLET
	1	CCW	CW	INLET

-A- CONTROL MTG. POSITION				
CONTROL OPTION	FIG.	PUMP ROT.	ROTARY SERVO INPUT SHAFT ROTATION	PORT "A"
"10"	2	CW	CW	INLET
	2	CCW	CCW	INLET

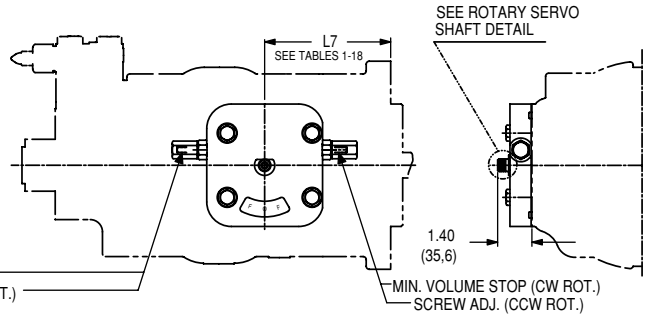
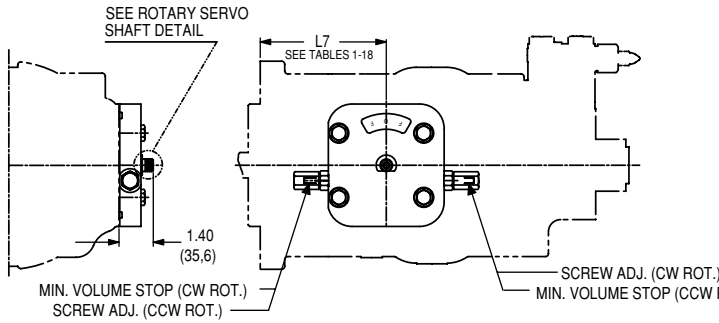

FIGURE -1

FIGURE -2

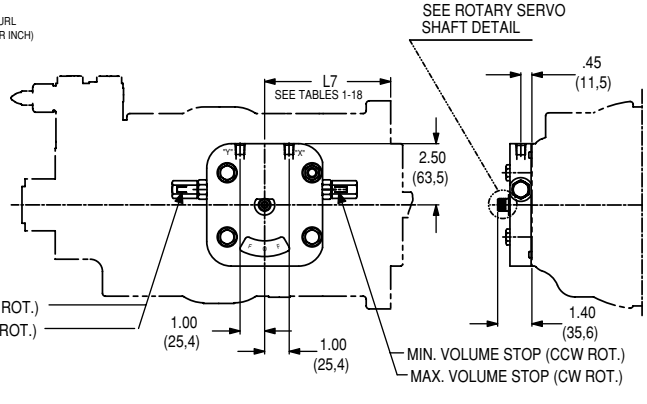
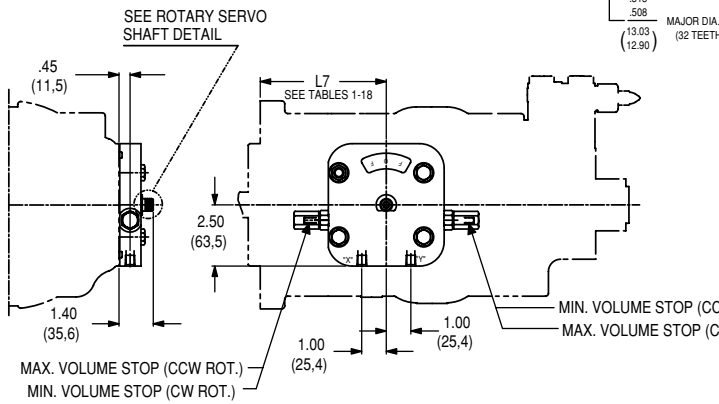
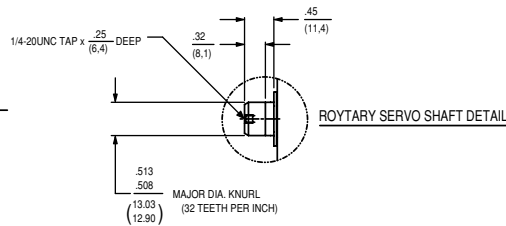

FIGURE -1

FIGURE -2

-B- CONTROL MTG. POSITION					
CONTROL SPRING OFF-SET TO MIN. VOLUME					
CONTROL OPTION	FIG.	PUMP ROT.	PRESSURE SIGNAL TO:		PORT "A"
			1/8-27 N.P.T.F. PORT "X"	1/8-27 N.P.T.F. PORT "Y"	
"2A"	1	CW	MAX. VOL.	MIN. VOL.	INLET
	1	CCW	MIN. VOL.	MAX. VOL.	INLET

-A- CONTROL MTG. POSITION					
CONTROL SPRING OFF-SET TO MIN. VOLUME					
CONTROL OPTION	FIG.	PUMP ROT.	PRESSURE SIGNAL TO:		PORT "A"
			1/8-27 N.P.T.F. PORT "X"	1/8-27 N.P.T.F. PORT "Y"	
"2A"	2	CW	MIN. VOL.	MAX. VOL.	INLET
	2	CCW	MAX. VOL.	MIN. VOL.	INLET

-B- CONTROL MTG. POSITION						
CONTROL SPRING OFF-SET TO MIN. VOLUME						
CONTROL OPTION	FIG.	PUMP ROT.	PRESSURE SIGNAL TO SAE-4 STR. THD. PORT:	ROTARY SERVO INPUT SHAFT ROTATION	PORT "A"	PORT "B"
"2H**"	1	CW	"X"	CCW	INLET	OUTLET
	1	CCW	"Y"	CW	INLET	OUTLET
	1	CW	"Y"	CW	OUTLET	INLET
	1	CCW	"X"	CCW	OUTLET	INLET

-A- CONTROL MTG. POSITION						
CONTROL SPRING OFF-SET TO MIN. VOLUME						
CONTROL OPTION	FIG.	PUMP ROT.	PRESSURE SIGNAL TO SAE-4 STR. THD. PORT:	ROTARY SERVO INPUT SHAFT ROTATION	PORT "A"	PORT "B"
"2H**"	2	CW	"Y"	CW	INLET	OUTLET
	2	CCW	"X"	CCW	INLET	OUTLET
	2	CW	"X"	CCW	OUTLET	INLET
	2	CCW	"Y"	CW	OUTLET	INLET

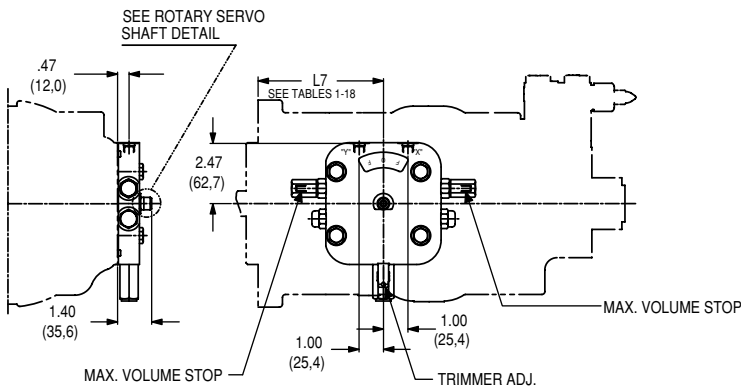

FIGURE -1

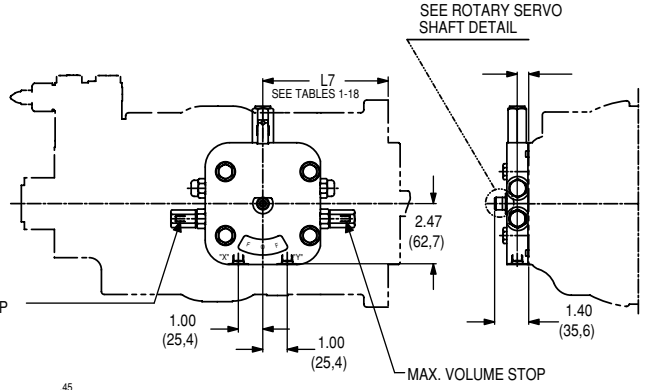

FIGURE -2

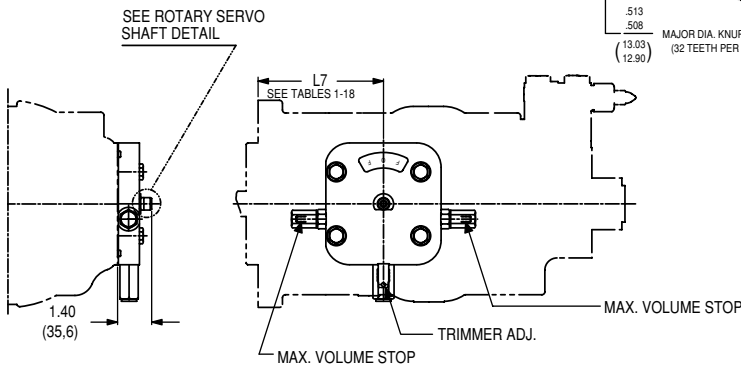
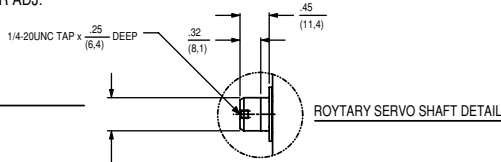

FIGURE -1

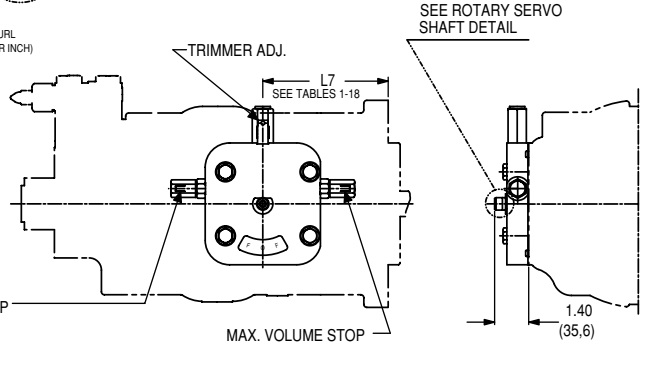

FIGURE -2

-B- CONTROL MTG. POSITION					
CONTROL SPRING OFF-SET TO MIN. VOLUME					
CONTROL OPTION	FIG.	PUMP ROT.	ROTARY SERVO INPUT SHAFT ROTATION	PORT "A"	PORT "B"
"4A**"	1	CW	CCW	INLET	OUTLET
	1	CCW	CW	INLET	OUTLET
	1	CW	CW	OUTLET	INLET
	1	CCW	CCW	OUTLET	INLET

-A- CONTROL MTG. POSITION					
CONTROL SPRING OFF-SET TO MIN. VOLUME					
CONTROL OPTION	FIG.	PUMP ROT.	ROTARY SERVO INPUT SHAFT ROTATION	PORT "A"	PORT "B"
"4A**"	2	CW	CW	INLET	OUTLET
	2	CCW	CCW	INLET	OUTLET
	2	CW	CCW	OUTLET	INLET
	2	CCW	CW	OUTLET	INLET

-B- CONTROL MTG. POSITION					
CONTROL SPRING OFF-SET TO MIN. VOLUME					
CONTROL OPTION	FIG.	PUMP ROT.	ROTARY SERVO INPUT SHAFT ROTATION	PORT "A"	PORT "B"
"5A**"	1	CW	CCW	INLET	OUTLET
	1	CCW	CW	INLET	OUTLET
	1	CW	CW	OUTLET	INLET
	1	CCW	CCW	OUTLET	INLET

-A- CONTROL MTG. POSITION					
CONTROL SPRING OFF-SET TO MIN. VOLUME					
CONTROL OPTION	FIG.	PUMP ROT.	ROTARY SERVO INPUT SHAFT ROTATION	PORT "A"	PORT "B"
"5A**"	2	CW	CW	INLET	OUTLET
	2	CCW	CCW	INLET	OUTLET
	2	CW	CCW	OUTLET	INLET
	2	CCW	CW	OUTLET	INLET

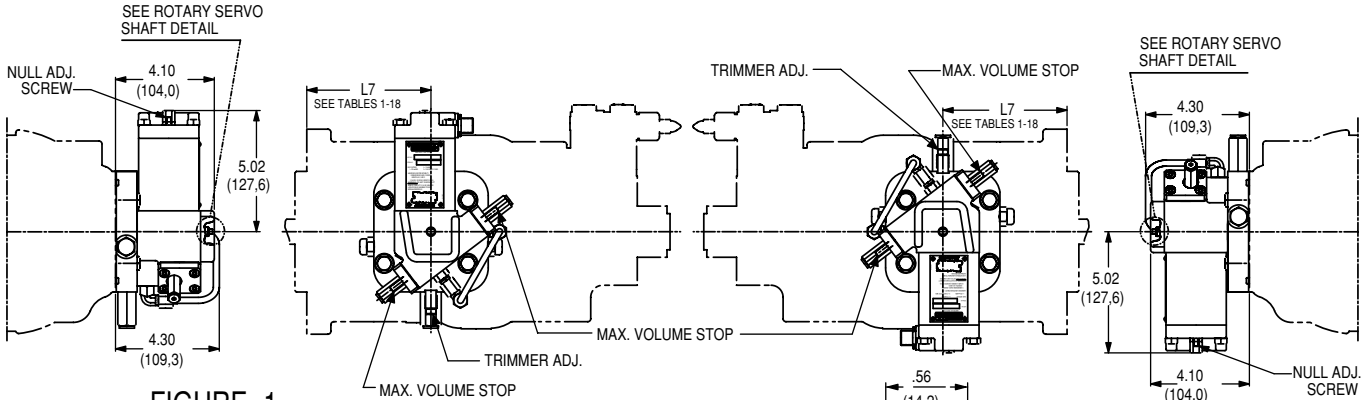

FIGURE -1

FIGURE -2

SEE ROTARY SERVO SHAFT DETAIL

NULL ADJ. SCREW

4.10 (104,0)

5.02 (127,6)

4.30 (109,3)

FIGURE -1

SEE ROTARY SERVO SHAFT DETAIL

TRIMMER ADJ.

MAX. VOLUME STOP

MAX. VOLUME STOP

TRIMMER ADJ.

MAX. VOLUME STOP

SEE ROTARY SERVO SHAFT DETAIL

NULL ADJ. SCREW

4.30 (109,3)

4.10 (104,0)

FIGURE -2

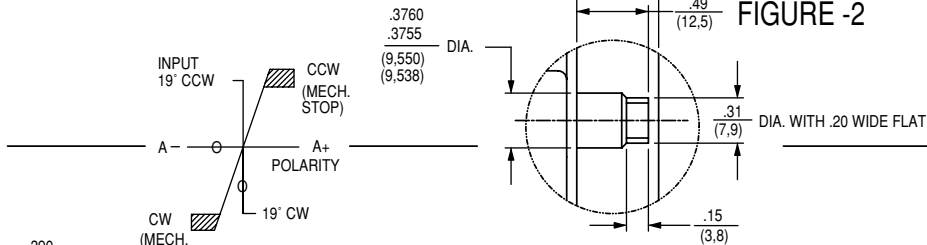

MANUAL OVERRIDE DETAIL

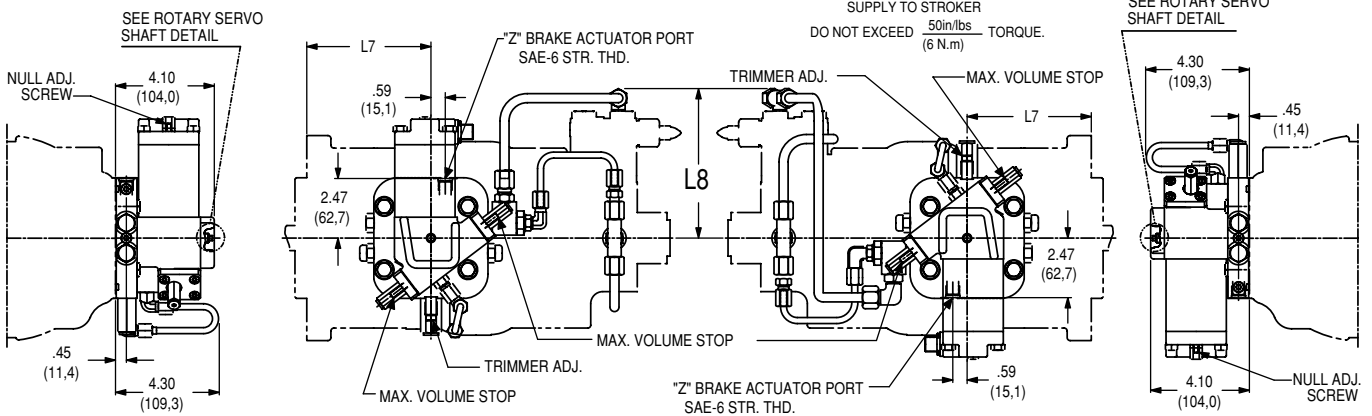

FIGURE -1

FIGURE -2

-B- CONTROL MTG. POSITION					
CONTROL SPRING OFF-SET TO MIN. VOLUME					
CONTROL OPTION	FIG.	PUMP ROT.	ROTARY SERVO INPUT SHAFT ROTATION	PORT "A"	PORT "B"
"5C**"	1	CW	CCW	INLET	OUTLET
	1	CCW	CW	INLET	OUTLET
	1	CW	CW	OUTLET	INLET
	1	CCW	CCW	OUTLET	INLET

SERIES SIZE	L7	L8
6, 7 & 8 (SAE 127-2)	5.15 (130,9)	6.20 (157,4)
6, 7 & 8 (SAE 152-4)	6.49 (164,8)	
11 & 14	6.38 (162,0)	6.77 (171,9)
24 & 30	8.14 (206,7)	8.64 (219,4)

-A- CONTROL MTG. POSITION					
CONTROL SPRING OFF-SET TO MIN. VOLUME					
CONTROL OPTION	FIG.	PUMP ROT.	ROTARY SERVO INPUT SHAFT ROTATION	PORT "A"	PORT "B"
"5C**"	2	CW	CW	INLET	OUTLET
	2	CCW	CCW	INLET	OUTLET
	2	CW	CCW	OUTLET	INLET
	2	CCW	CW	OUTLET	INLET

-B- CONTROL MTG. POSITION					
CONTROL OPTION	FIG.	PUMP ROT.	IINDICATOR ROTATION	PORT "A"	PORT "B"
"7D"	1	CW	CCW	INLET	OUTLET
	1	CCW	CW	INLET	OUTLET
	1	CW	CW	OUTLET	INLET
	1	CCW	CCW	OUTLET	INLET

SERIES SIZE	L7	L8	L9
6, 7 & 8 (SAE 127-2)	5.15 (130.9)	9.43 (239.6)	5.63 (143.1)
6, 7 & 8 (SAE 152-4)	6.49 (164.8)		
11 & 14	6.38 (162.0)	10.00 (254.1)	6.20 (157.5)
24 & 30	8.14 (206.7)	11.87 (301.5)	8.07 (205.0)

-A- CONTROL MTG. POSITION					
CONTROL OPTION	FIG.	PUMP ROT.	IINDICATOR ROTATION	PORT "A"	PORT "B"
"7D"	2	CW	CW	INLET	OUTLET
	2	CCW	CCW	INLET	OUTLET
	2	CW	CCW	OUTLET	INLET
	2	CCW	CW	OUTLET	INLET

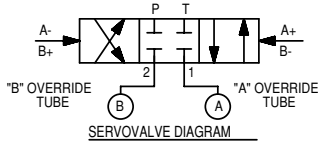

PUMP ROT.	CAM	SERVOVALVE		PORT "A"	PORT "B"
		COIL POLARITY	PORTING		
CW	ABOVE	A+ or B-	P--2	OUTLET	INLET
CW	BELOW	A- or B+	P--1	INLET	OUTLET
CCW	BELOW	A+ or B-	P--2	OUTLET	INLET
CCW	ABOVE	A- or B+	P--1	INLET	OUTLET

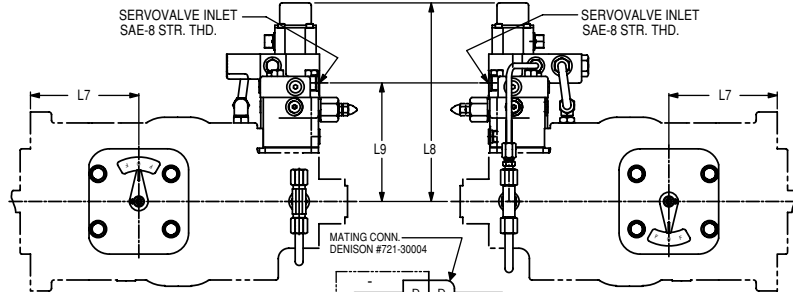
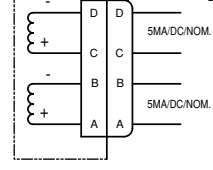

FIGURE -1

FIGURE -2



SERVOVALVE DIAGRAM

-B- CONTROL MTG. POSITION						
CONTROL OPTION	FIG.	PUMP ROT.	ENERGIZE SOLENOID	IINDICATOR ROTATION	PORT "A"	PORT "B"
"7J"	1	CW	B	CCW	INLET	OUTLET
	1	CCW	A	CW	INLET	OUTLET
	1	CW	A	CW	OUTLET	INLET
	1	CCW	B	CCW	OUTLET	INLET

SERIES SIZE	L7	L8	L9
6, 7 & 8 (SAE 127-2)	5.15 (130.9)	10.63 (270.1)	5.63 (143.1)
6, 7 & 8 (SAE 152-4)	6.49 (164.8)		
11 & 14	6.38 (162.0)	11.20 (284.5)	6.20 (157.5)
24 & 30	8.14 (206.7)	13.07 (332.0)	8.07 (205.0)

-A- CONTROL MTG. POSITION						
CONTROL OPTION	FIG.	PUMP ROT.	ENERGIZE SOLENOID	IINDICATOR ROTATION	PORT "A"	PORT "B"
"7J"	2	CW	A	CW	INLET	OUTLET
	2	CCW	B	CCW	INLET	OUTLET
	2	CW	B	CCW	OUTLET	INLET
	2	CCW	A	CW	OUTLET	INLET

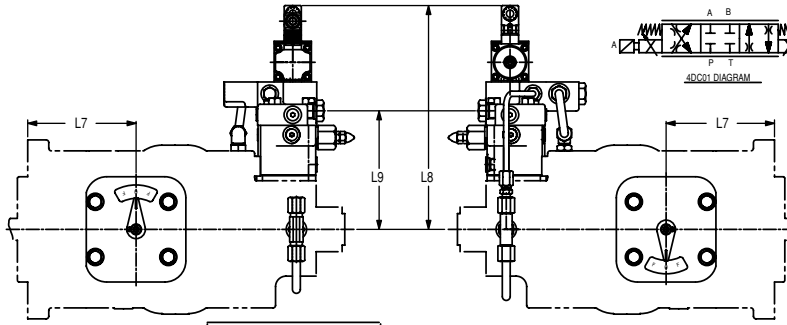
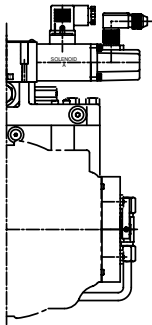
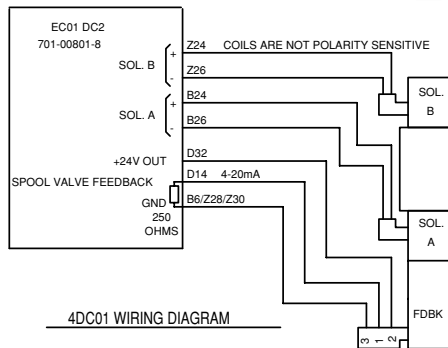

FIGURE -1

FIGURE -2



-B- CONTROL MTG. POSITION					
CONTROL OPTION	FIG.	PUMP ROT.	ROTARY SERVO INPUT SHAFT ROTATION	PORT "A"	PORT "B"
"7F"	1	CW	CCW	INLET	OUTLET
	1	CCW	CW	INLET	OUTLET
	1	CW	CW	OUTLET	INLET
	1	CCW	CCW	OUTLET	INLET

SERIES SIZE	L7	L8	L9
6, 7 & 8 (SAE 127-2)	5.15 (130.9)	9.43 (239.6)	5.63 (143.1)
6, 7 & 8 (SAE 152-4)	6.49 (164.8)		
11 & 14	6.38 (162.0)	10.00 (254.1)	6.20 (157.5)
24 & 30	8.14 (206.7)	11.87 (301.5)	8.07 (205.0)

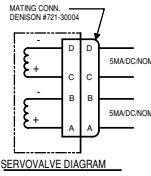

-A- CONTROL MTG. POSITION					
CONTROL OPTION	FIG.	PUMP ROT.	ROTARY SERVO INPUT SHAFT ROTATION	PORT "A"	PORT "B"
"7F"	2	CW	CW	INLET	OUTLET
	2	CCW	CCW	INLET	OUTLET
	2	CW	CCW	OUTLET	INLET
	2	CCW	CW	OUTLET	INLET

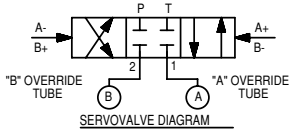

PUMP ROT.	CAM	SERVOVALVE		PORT "A"	PORT "B"
		COIL POLARITY	PORTING		
CW	ABOVE	A+ or B-	P--2	OUTLET	INLET
CW	BELOW	A- or B+	P--1	INLET	OUTLET
CCW	BELOW	A+ or B-	P--2	OUTLET	INLET
CCW	ABOVE	A- or B+	P--1	INLET	OUTLET

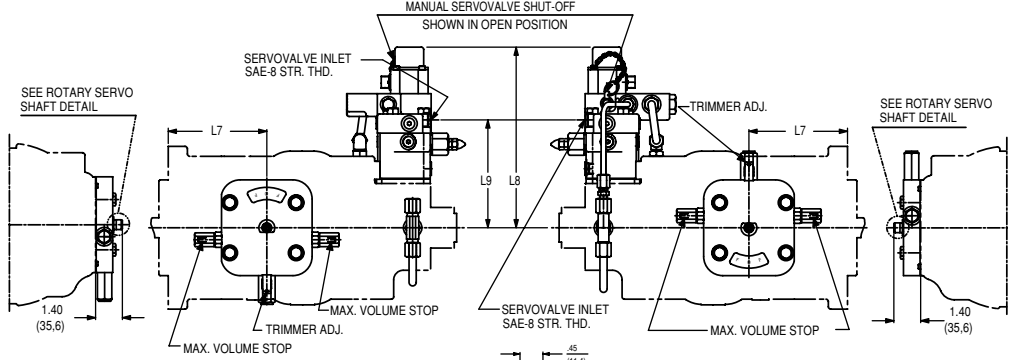

FIGURE -1

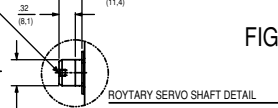

FIGURE -2

SERIES SIZE	L7	L8	L9
6, 7 & 8 (SAE 127-2)	5.15 (130.9)	10.63 (270.1)	5.63 (143.1)
6, 7 & 8 (SAE 152-4)	6.49 (164.8)		
11 & 14	6.38 (162.0)	11.20 (284.5)	6.20 (157.5)
24 & 30	8.14 (206.7)	13.07 (332.0)	8.07 (205.0)

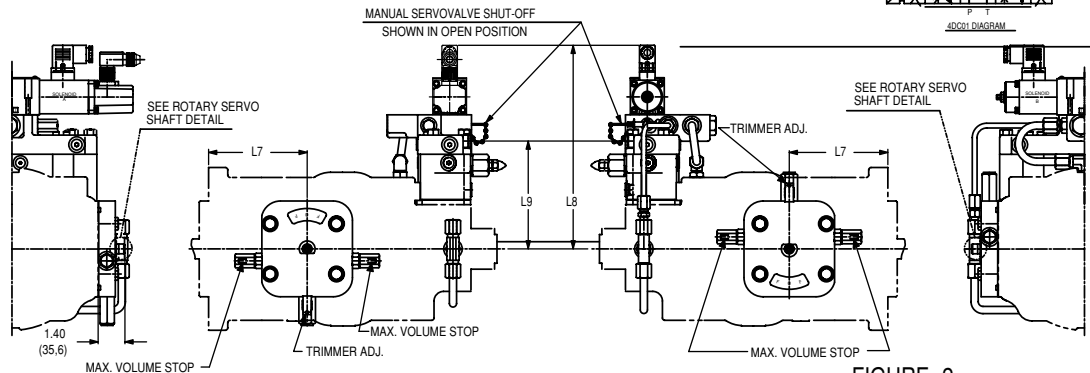
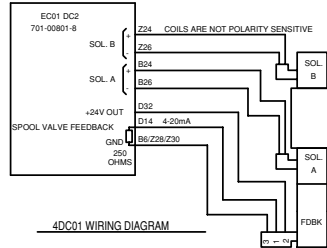

FIGURE -1

FIGURE -2

-B- CONTROL MTG. POSITION						
CONTROL OPTION	FIG.	PUMP ROT.	ENERGIZE SOLENOID	ROTARY SERVO INPUT SHAFT ROTATION	PORT "A"	PORT "B"
"7K"	1	CW	B	CCW	INLET	OUTLET
	1	CCW	A	CW	INLET	OUTLET
	1	CW	A	CW	OUTLET	INLET
	1	CCW	B	CCW	OUTLET	INLET



-A- CONTROL MTG. POSITION						
CONTROL OPTION	FIG.	PUMP ROT.	ENERGIZE SOLENOID	ROTARY SERVO INPUT SHAFT ROTATION	PORT "A"	PORT "B"
"7K"	2	CW	A	CW	INLET	OUTLET
	2	CCW	B	CCW	INLET	OUTLET
	2	CW	B	CCW	OUTLET	INLET
	2	CCW	A	CW	OUTLET	INLET

-B- CONTROL MTG. POSITION						
CONTROL SPRING OFF-SET TO MIN. VOLUME						
CONTROL OPTION	FIG.	PUMP ROT.	PRESSURE SIGNAL TO SAE-4 STR. THD. PORT:	ROTARY SERVO INPUT SHAFT ROTATION	PORT "A"	PORT "B"
"8A**"	1	CW	"P1"	CCW	INLET	OUTLET
	1	CCW	"P2"	CW	INLET	OUTLET
	1	CW	"P2"	CW	OUTLET	INLET
	1	CCW	"P1"	CCW	OUTLET	INLET

-A- CONTROL MTG. POSITION						
CONTROL SPRING OFF-SET TO MIN. VOLUME						
CONTROL OPTION	FIG.	PUMP ROT.	PRESSURE SIGNAL TO SAE-4 STR. THD. PORT:	ROTARY SERVO INPUT SHAFT ROTATION	PORT "A"	PORT "B"
"8A**"	2	CW	"P2"	CW	INLET	OUTLET
	2	CCW	"P1"	CCW	INLET	OUTLET
	2	CW	"P1"	CCW	OUTLET	INLET
	2	CCW	"P2"	CW	OUTLET	INLET

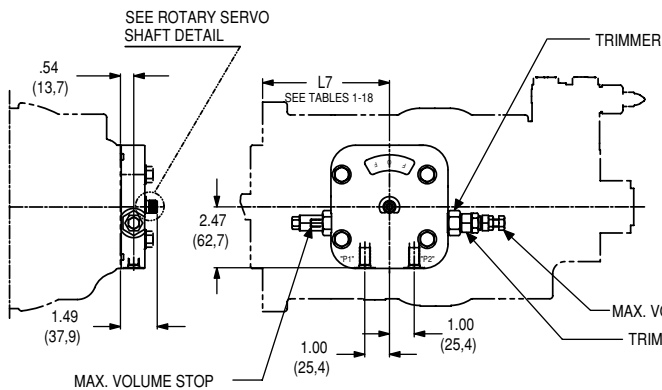

FIGURE -1

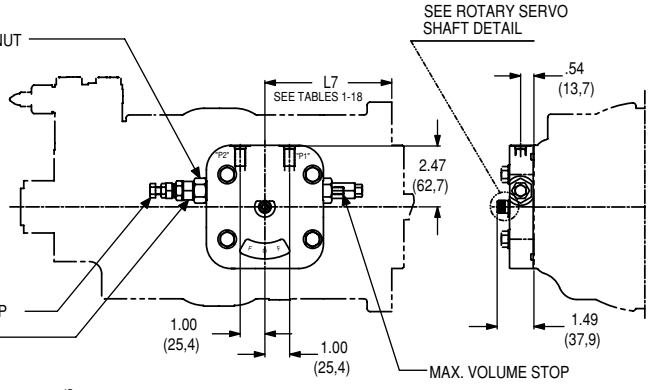

FIGURE -2

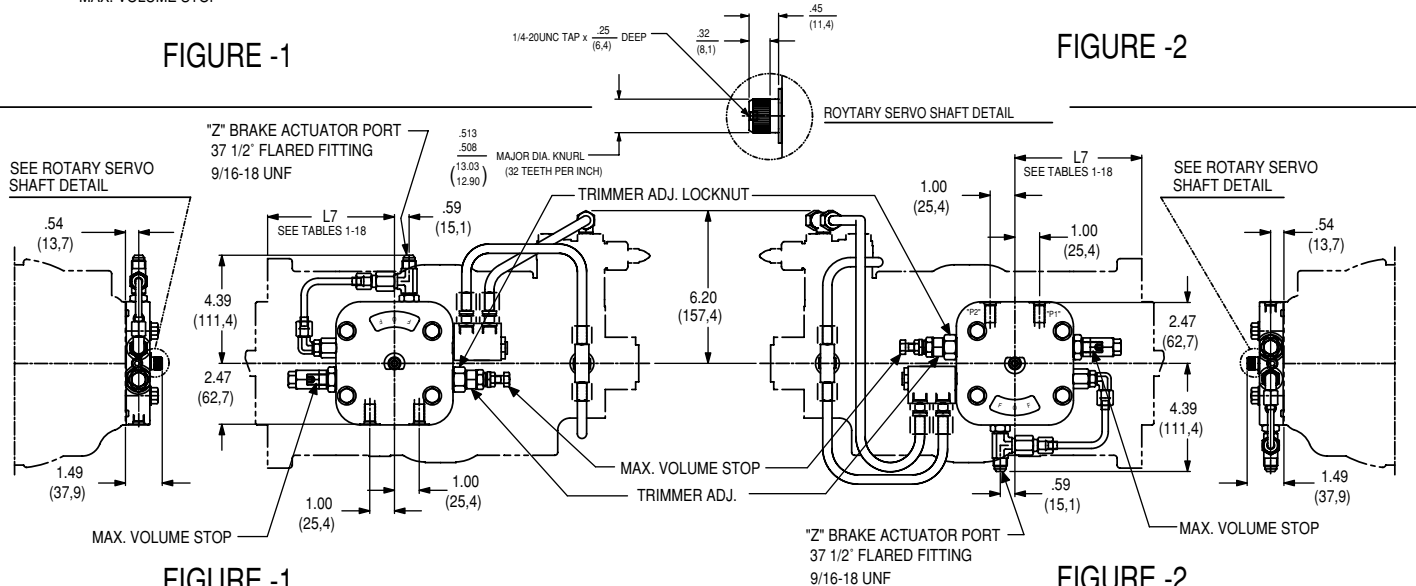

FIGURE -1

FIGURE -2

-B- CONTROL MTG. POSITION						
CONTROL SPRING OFF-SET TO MIN. VOLUME						
CONTROL OPTION	FIG.	PUMP ROT.	PRESSURE SIGNAL TO SAE-4 STR. THD. PORT:	ROTARY SERVO INPUT SHAFT ROTATION	PORT "A"	PORT "B"
"8C**"	1	CW	"P1"	CCW	INLET	OUTLET
	1	CCW	"P2"	CW	INLET	OUTLET
	1	CW	"P2"	CW	OUTLET	INLET
	1	CCW	"P1"	CCW	OUTLET	INLET

-A- CONTROL MTG. POSITION						
CONTROL SPRING OFF-SET TO MIN. VOLUME						
CONTROL OPTION	FIG.	PUMP ROT.	PRESSURE SIGNAL TO SAE-4 STR. THD. PORT:	ROTARY SERVO INPUT SHAFT ROTATION	PORT "A"	PORT "B"
"8C**"	2	CW	"P2"	CW	INLET	OUTLET
	2	CCW	"P1"	CCW	INLET	OUTLET
	2	CW	"P1"	CCW	OUTLET	INLET
	2	CCW	"P2"	CW	OUTLET	INLET

-B- CONTROL MTG. POSITION						
CONTROL OPTION	FIG.	PUMP ROT.	ENERGIZE SOLENOID	MANUAL OVERRIDE SHAFT ROTATION	PORT "A"	PORT "B"
"9A**"	1	CW	"A"	CCW	INLET	OUTLET
	1	CCW	"B"	CW	INLET	OUTLET
	1	CW	"B"	CW	OUTLET	INLET
	1	CCW	"A"	CCW	OUTLET	INLET

-A- CONTROL MTG. POSITION						
CONTROL OPTION	FIG.	PUMP ROT.	ENERGIZE SOLENOID	MANUAL OVERRIDE SHAFT ROTATION	PORT "A"	PORT "B"
"9A**"	2	CW	"B"	CW	INLET	OUTLET
	2	CCW	"A"	CCW	INLET	OUTLET
	2	CW	"A"	CCW	OUTLET	INLET
	2	CCW	"B"	CW	OUTLET	INLET

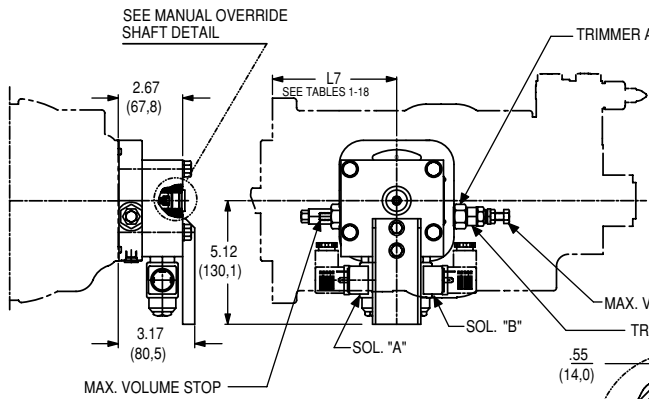

FIGURE -1

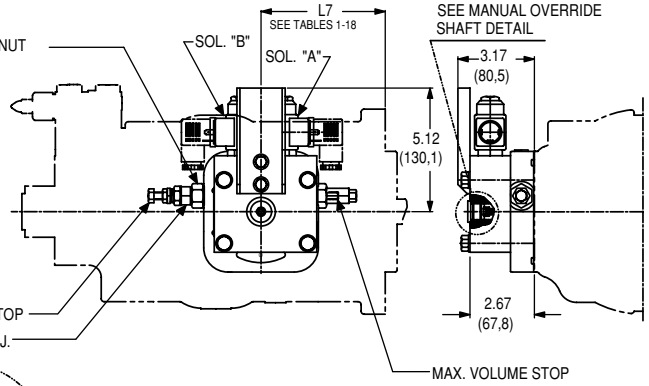
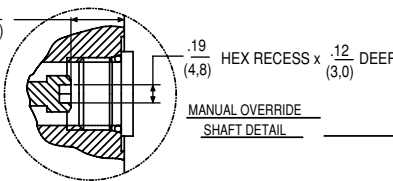

FIGURE -2



MANUAL OVERRIDE SHAFT DETAIL

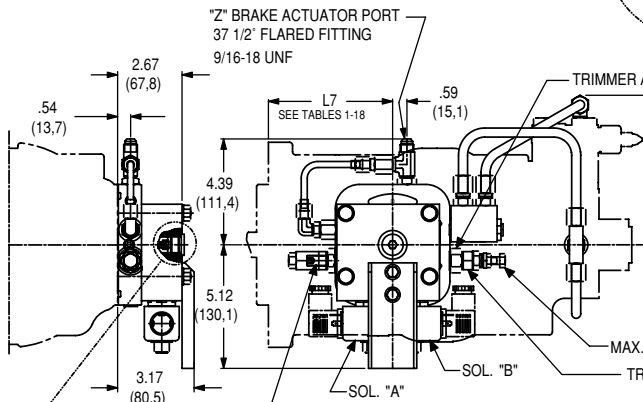

FIGURE -1

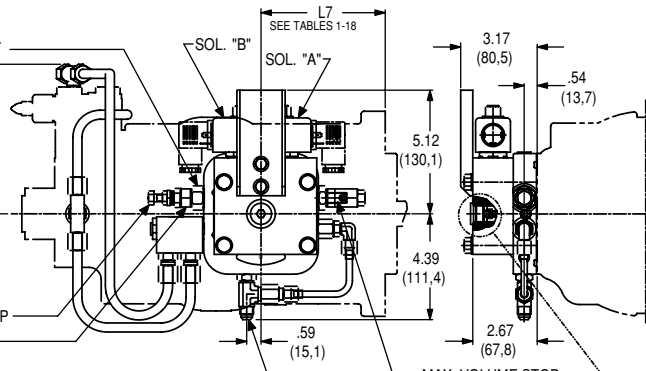

FIGURE -2

-B- CONTROL MTG. POSITION						
CONTROL OPTION	FIG.	PUMP ROT.	ENERGIZE SOLENOID	MANUAL OVERRIDE SHAFT ROTATION	PORT "A"	PORT "B"
"9C**"	1	CW	"A"	CCW	INLET	OUTLET
	1	CCW	"B"	CW	INLET	OUTLET
	1	CW	"B"	CW	OUTLET	INLET
	1	CCW	"A"	CCW	OUTLET	INLET

-A- CONTROL MTG. POSITION						
CONTROL OPTION	FIG.	PUMP ROT.	ENERGIZE SOLENOID	MANUAL OVERRIDE SHAFT ROTATION	PORT "A"	PORT "B"
"9C**"	2	CW	"B"	CW	INLET	OUTLET
	2	CCW	"A"	CCW	INLET	OUTLET
	2	CW	"A"	CCW	OUTLET	INLET
	2	CCW	"B"	CW	OUTLET	INLET

-B- CONTROL MTG. POSITION						
CONTROL SPRING OFF-SET TO FULL VOLUME						
CONTROL OPTION	FIG.	MOTOR ROT.	PRESSURE SIGNAL TO SAE-4 STR. THD. PORT P2	ROTARY SERVO INPUT SHAFT ROTATION	PORT "A"	PORT "B"
"8A**"	1	CW	FULL SPEED	CW	INLET	OUTLET
	1	CCW		CW	OUTLET	INLET

-A- CONTROL MTG. POSITION						
CONTROL SPRING OFF-SET TO FULL VOLUME						
CONTROL OPTION	FIG.	MOTOR ROT.	PRESSURE SIGNAL TO SAE-4 STR. THD. PORT P1	ROTARY SERVO INPUT SHAFT ROTATION	PORT "A"	PORT "B"
"8A**"	2	CW	FULL SPEED	CCW	INLET	OUTLET
	2	CCW		CCW	OUTLET	INLET

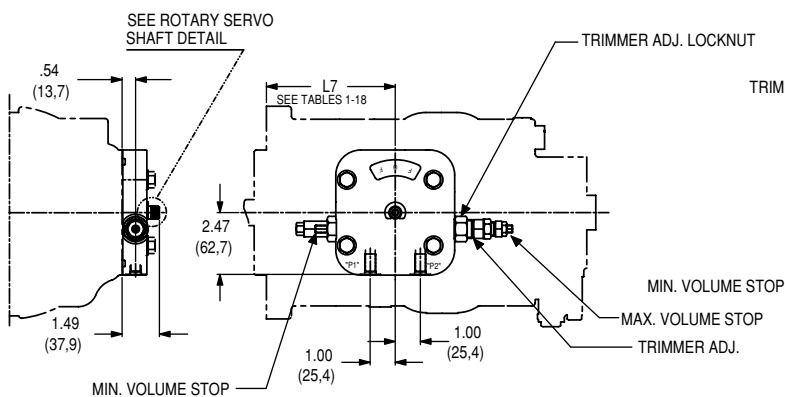

FIGURE -1

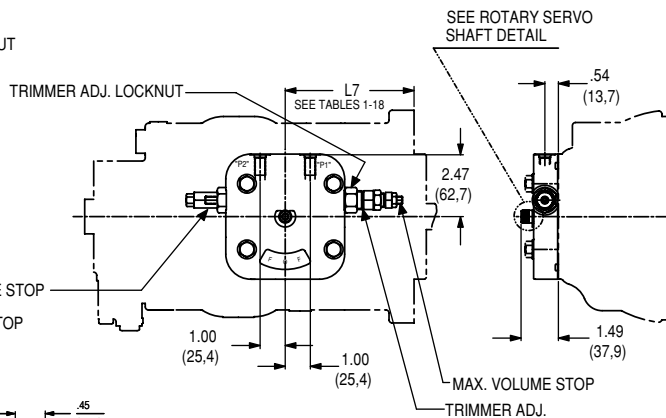

FIGURE -2

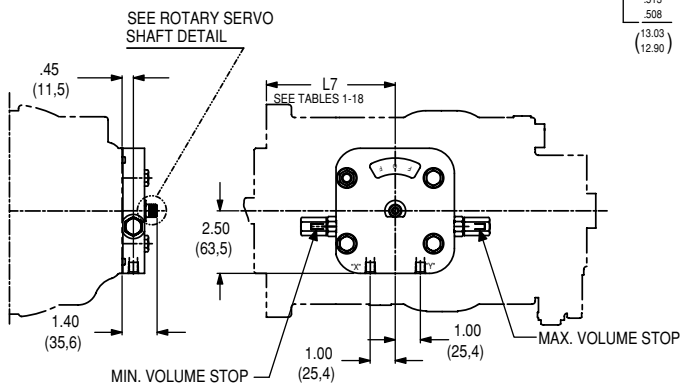
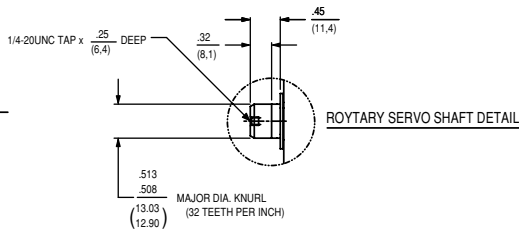

FIGURE -1

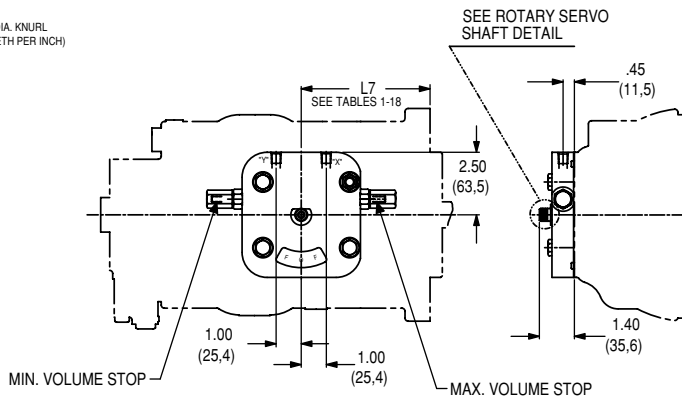

FIGURE -2

-B- CONTROL MTG. POSITION					
CONTROL SPRING OFF-SET TO FULL VOLUME					
CONTROL OPTION	FIG.	MOTOR ROT.	PRESSURE SIGNAL TO:		PORT "A"
			1/8-27 N.P.T.F. PORT "X"	1/8-27 N.P.T.F. PORT "Y"	
"2A**"	1	CW	REDUCED SPEED	FULL SPEED	INLET
	1	CCW			OUTLET

-A- CONTROL MTG. POSITION					
CONTROL SPRING OFF-SET TO FULL VOLUME					
CONTROL OPTION	FIG.	MOTOR ROT.	PRESSURE SIGNAL TO:		PORT "A"
			1/8-27 N.P.T.F. PORT "X"	1/8-27 N.P.T.F. PORT "Y"	
"2A**"	2	CW	FULL SPEED	REDUCED SPEED	INLET
	2	CCW			OUTLET

-B- CONTROL MTG. POSITION						
CONTROL SPRING OFF-SET TO FULL VOLUME						
CONTROL OPTION	FIG.	MOTOR ROT.	ROTARY SERVO INPUT SHAFT CCW ROTATION	ROTARY SERVO INPUT SHAFT CW ROTATION	PORT "A"	PORT "B"
"5A**"	1	CW			INLET	OUTLET
	1	CCW	REDUCED SPEED	FULL SPEED	OUTLET	INLET

-A- CONTROL MTG. POSITION						
CONTROL SPRING OFF-SET TO FULL VOLUME						
CONTROL OPTION	FIG.	MOTOR ROT.	ROTARY SERVO INPUT SHAFT CCW ROTATION	ROTARY SERVO INPUT SHAFT CW ROTATION	PORT "A"	PORT "B"
"5A**"	2	CW			INLET	OUTLET
	2	CCW	FULL SPEED	REDUCED SPEED	OUTLET	INLET

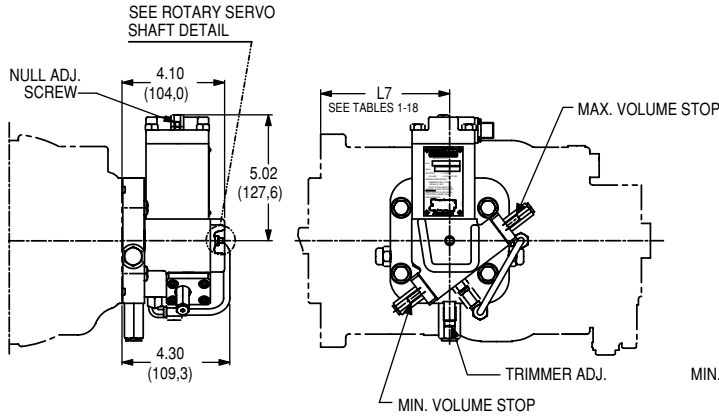
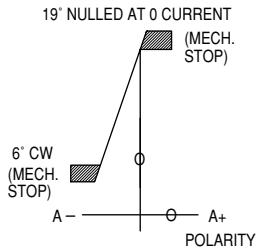

FIGURE -1



CURRENT AT FULL DISPL.
 350 MA. NOM.
 COIL RESISTANCE
 25 Ω NOM.
 WITH ELECTRICAL POLARITY AS SHOWN
 INPUT SHAFT WILL ROTATE CW
ELECTRICAL INPUT
 (ELECT. RECEPTACLE CONN. 5/8-24UNEF x ^{.390}/_(9,91) MAX.
 MATING CONN. HALF, MS3106E-10SL-4S)

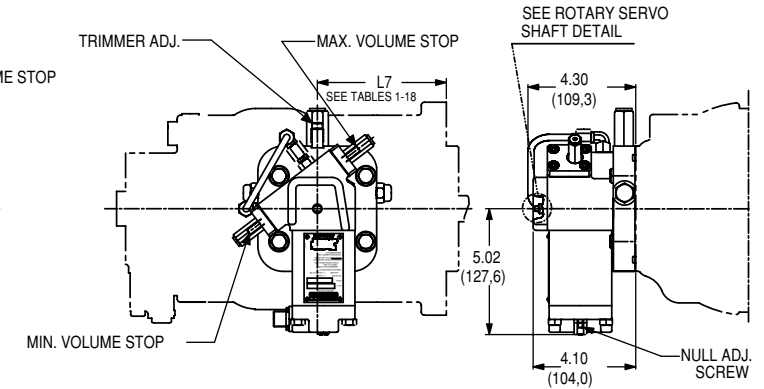
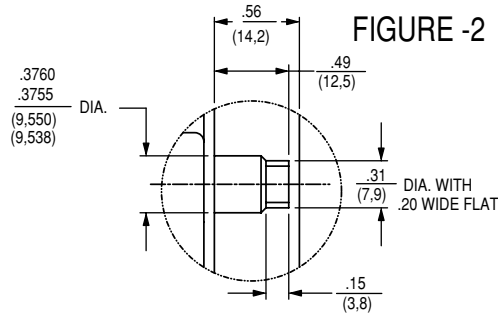

FIGURE -2



MANUAL OVERRIDE DETAIL

-B- CONTROL MTG. POSITION						
CONTROL SPRING OFF-SET TO FULL VOLUME						
CONTROL OPTION	FIG.	MOTOR ROT.	ENERGIZE SOLENOID	MANUAL OVERRIDE SHAFT ROTATION	PORT "A"	PORT "B"
"9A**"	1	CW		CW	INLET	OUTLET
	1	CCW	FULL SPEED	CW	OUTLET	INLET

-A- CONTROL MTG. POSITION						
CONTROL SPRING OFF-SET TO FULL VOLUME						
CONTROL OPTION	FIG.	MOTOR ROT.	ENERGIZE SOLENOID	MANUAL OVERRIDE SHAFT ROTATION	PORT "A"	PORT "B"
"9A**"	2	CW		CCW	INLET	OUTLET
	2	CCW	FULL SPEED	CCW	OUTLET	INLET

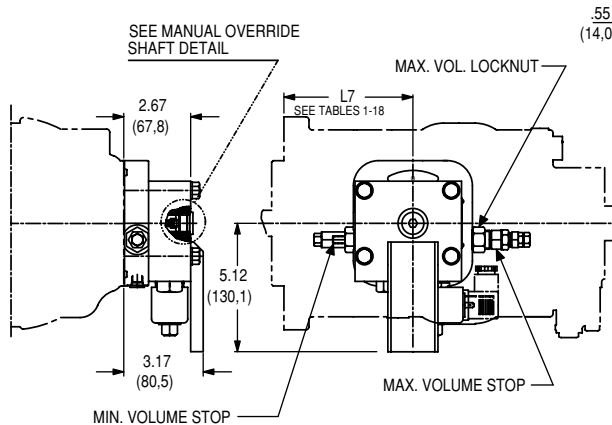

FIGURE -1

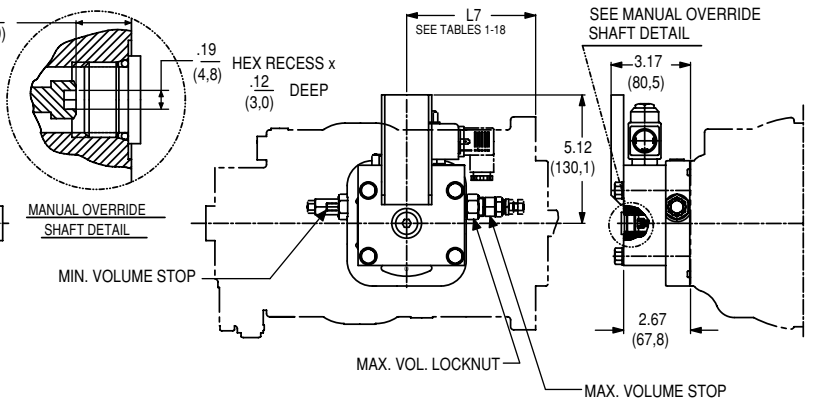

FIGURE -2

-A- CONTROL MTG. POSITION

CONTROL OPTION	FIG.	PUMP ROT.	INPUT SHAFT ROTATION	PORT "A"	PORT "B"	TORQUE LIMITER ADJ.
***4"	3	CW	CW	INLET	OUTLET	E
	1	CCW	CCW	INLET	OUTLET	F
	1	CCW	CW	OUTLET	INLET	E
	3	CW	CCW	OUTLET	INLET	F

SERIES SIZE	L7	L10	L11
6, 7 & 8 (SAE 127-2)	5.15 (130.9)	6.20 (157.4)	6.48 (164.5)
6, 7 & 8 (SAE 152-4)	6.49 (164.8)		
11 & 14	6.38 (162.0)	5.83 (148.0)	5.83 (148.0)
24 & 30	8.14 (206.7)	7.15 (181.6)	7.15 (181.6)

-B- CONTROL MTG. POSITION

CONTROL OPTION	FIG.	PUMP ROT.	INPUT SHAFT ROTATION	PORT "A"	PORT "B"	TORQUE LIMITER ADJ.
***4"	4	CW	CCW	INLET	OUTLET	F
	2	CCW	CW	INLET	OUTLET	E
	2	CCW	CCW	OUTLET	INLET	F
	4	CW	CW	OUTLET	INLET	E

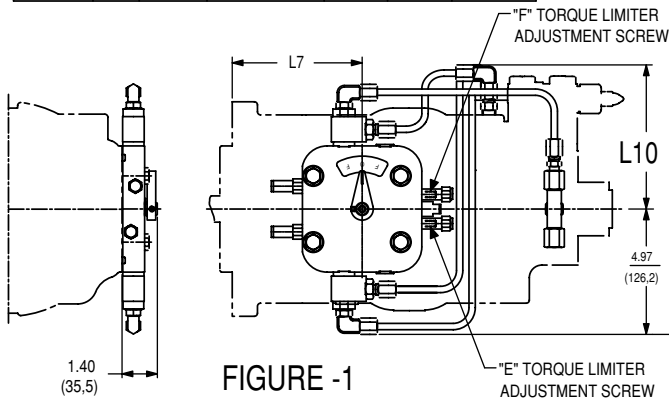

FIGURE -1

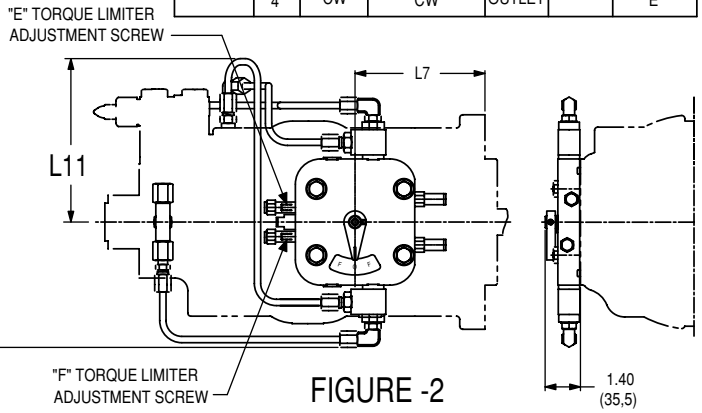

FIGURE -2

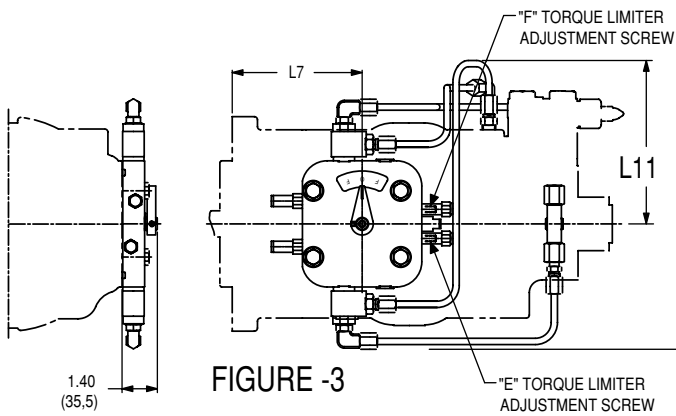

FIGURE -3

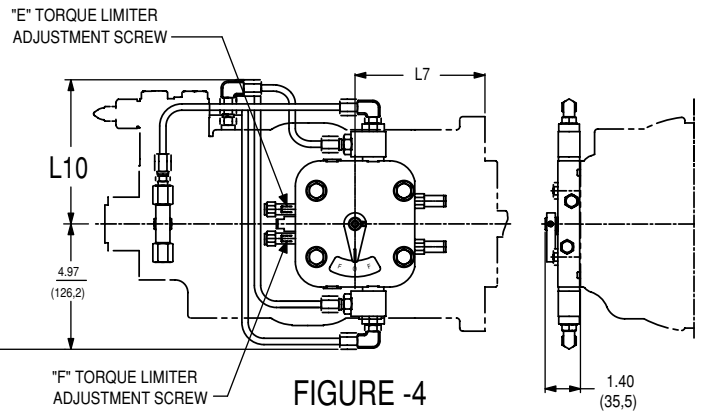
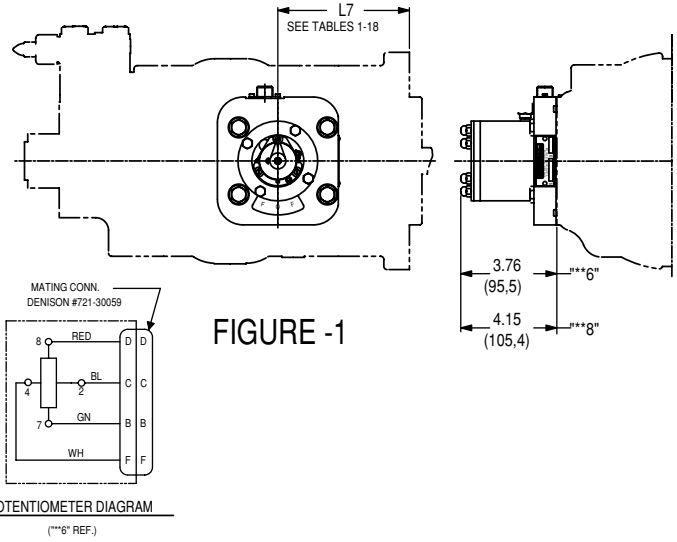
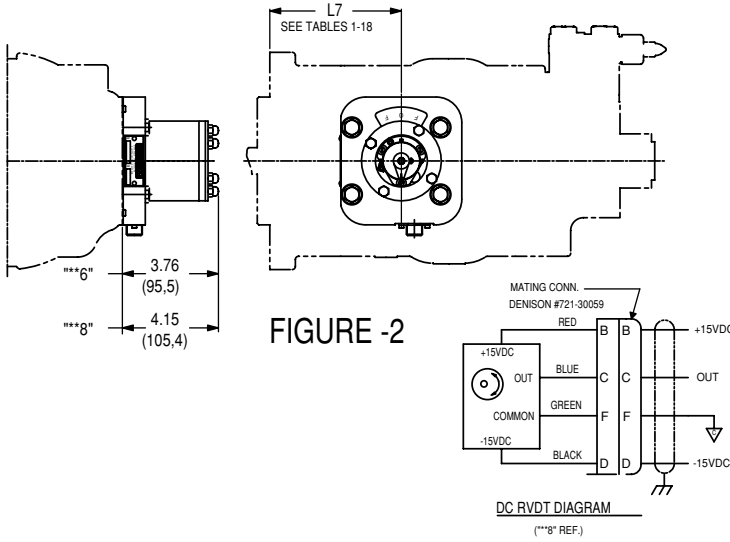

FIGURE -4

-A- CONTROL MTG. POSITION					
CONTROL OPTION	FIG.	PUMP ROT.	INPUT SHAFT ROTATION	PORT "A"	PORT "B"
***6" or ***8"	2	CW	CW	INLET	OUTLET
	2	CCW	CCW	INLET	OUTLET
	2	CW	CCW	OUTLET	INLET
	2	CCW	CW	OUTLET	INLET

-B- CONTROL MTG. POSITION					
CONTROL OPTION	FIG.	PUMP ROT.	INPUT SHAFT ROTATION	PORT "A"	PORT "B"
***6" or ***8"	1	CW	CCW	INLET	OUTLET
	1	CCW	CW	INLET	OUTLET
	1	CW	CW	OUTLET	INLET
	1	CCW	CCW	OUTLET	INLET



-A- CONTROL MTG. POSITION					
CONTROL OPTION	FIG.	PUMP ROT.	INPUT SHAFT ROTATION	PORT "A"	PORT "B"
***2"	2	CW	CW	INLET	OUTLET
	2	CCW	CCW	INLET	OUTLET
	2	CW	CCW	OUTLET	INLET
	2	CCW	CW	OUTLET	INLET

-B- CONTROL MTG. POSITION					
CONTROL OPTION	FIG.	PUMP ROT.	INPUT SHAFT ROTATION	PORT "A"	PORT "B"
***2"	1	CW	CCW	INLET	OUTLET
	1	CCW	CW	INLET	OUTLET
	1	CW	CW	OUTLET	INLET
	1	CCW	CCW	OUTLET	INLET

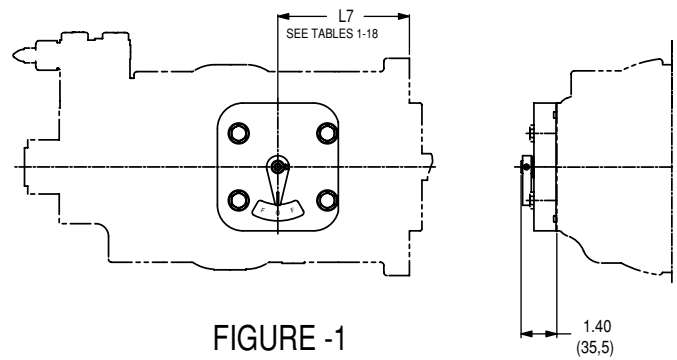
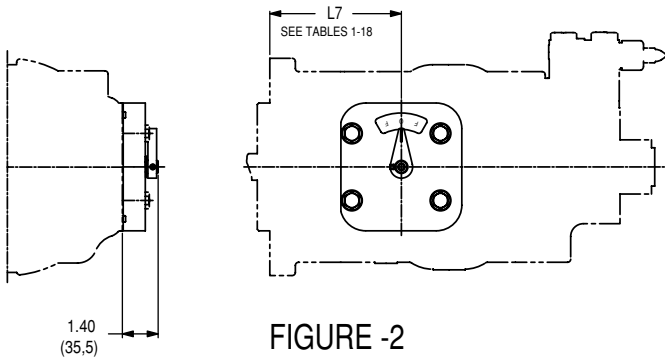

Rear drives(P6P-02R1C-8A2-A00-0**B**1-M2

		SAE Mounting & Coupling							
Mounting	None / plugged	82-2 (A)	101-2 (B)	101-4 (B)	127-2 (C)	127-4 (C)	152-4 (D)	165-4 (E)	177-4 (F)
coupling		16-4 (A)	22-4 (B)	22-4 (B)	32-4 (C)	32-4 (C)	44-4 (D)	44-4 (E)	50-4 (F)
P6,7,8	0	A	B	-	-	-	-	-	-
P6,7,8 R,L	0	A	B	-	C	-	-	-	-
P11,14	0	A	B	-	-	-	-	-	-
P11,14 R,L	0	A	B	-	C	C	D	E	-
P24,30	0	-	B	-	C	-	-	-	-
P24,30 R,L	0	-	B	B	C	C	D	E	F

P6-14 S,X
 SAE 82-2 (A) WITH COUPLING 16-4
 SAE 101-2 (B) WITH COUPLING 22-4

NOTE:
 1. REAR AUXILIARY UNIT TO LIMIT COUPLING TRAVEL .28 MINIMUM FROM MOUNTING FACE (SAE STD. REF.)
 (7,1)

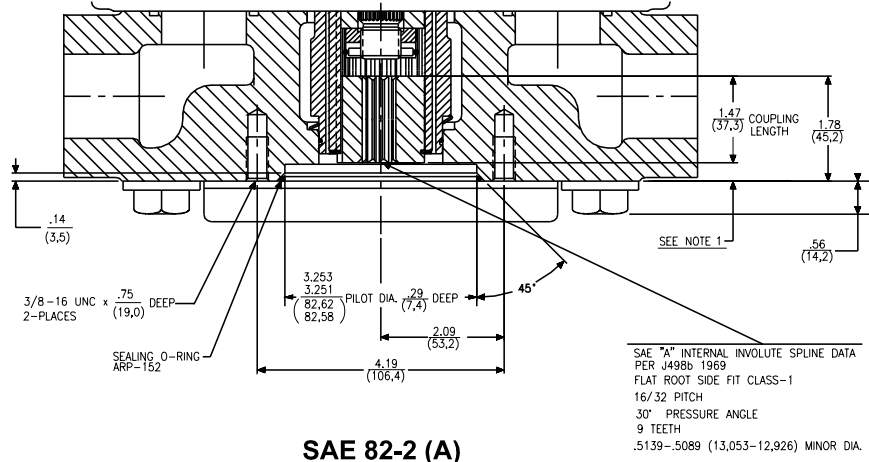

SAE 82-2 (A)

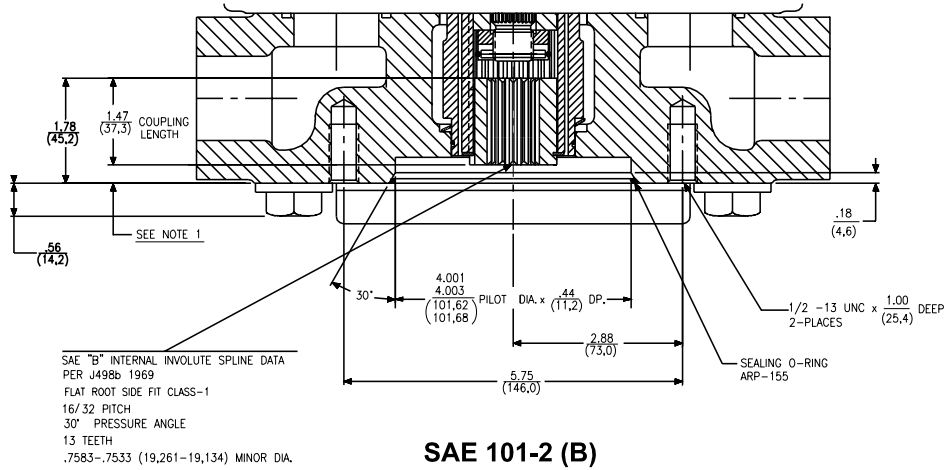

SAE 101-2 (B)

M6,7 R,L,M,N
 P6,7,8 R,L,M
 SAE 127-2 (C) WITH COUPLING 32-4
 SAE 101-2 (B) WITH COUPLING 22-4
 SAE 82-2 (A) WITH COUPLING 16-4

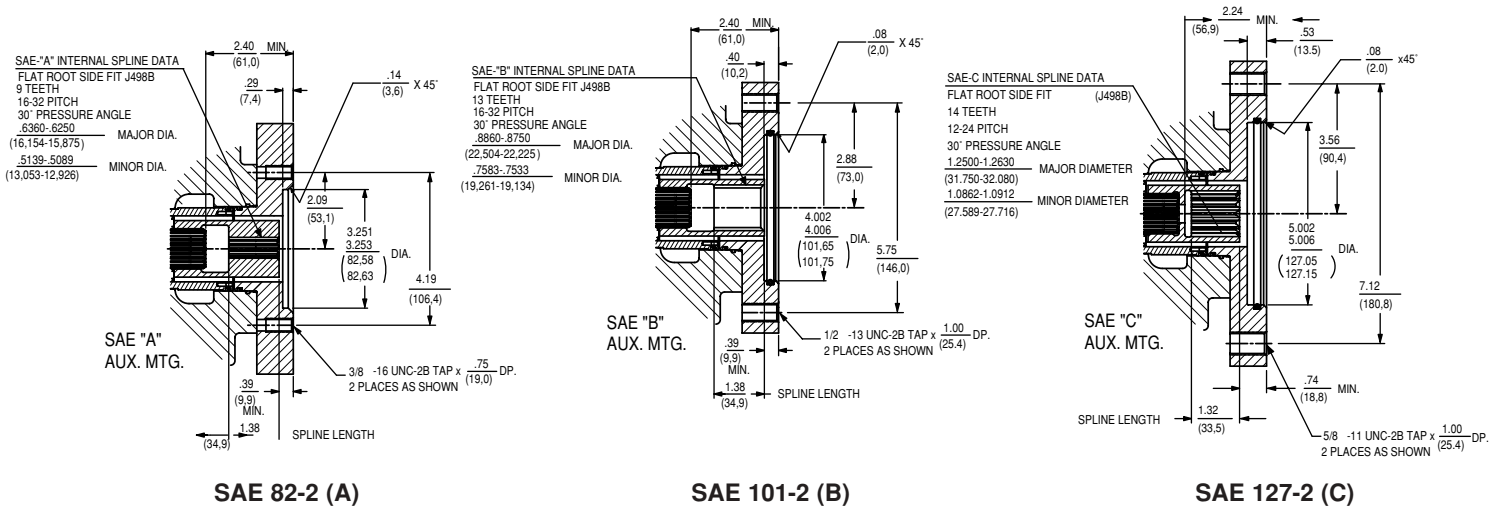

SAE 82-2 (A)

SAE 101-2 (B)

SAE 127-2 (C)

M11,14 R,L,M,N
P11,14 R,L
BLANKING PLATE

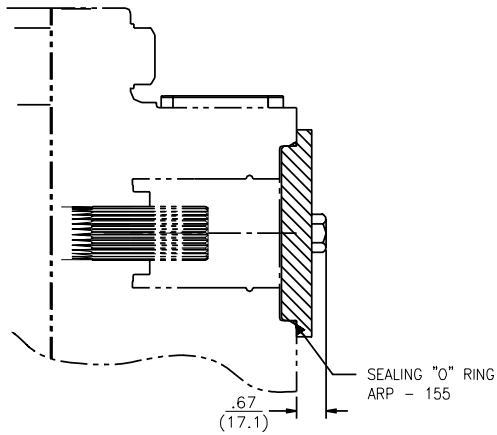

M11,14 R,L,M,N
P11,14 R,L
SAE 82-2 (A) WITH COUPLING 16-4

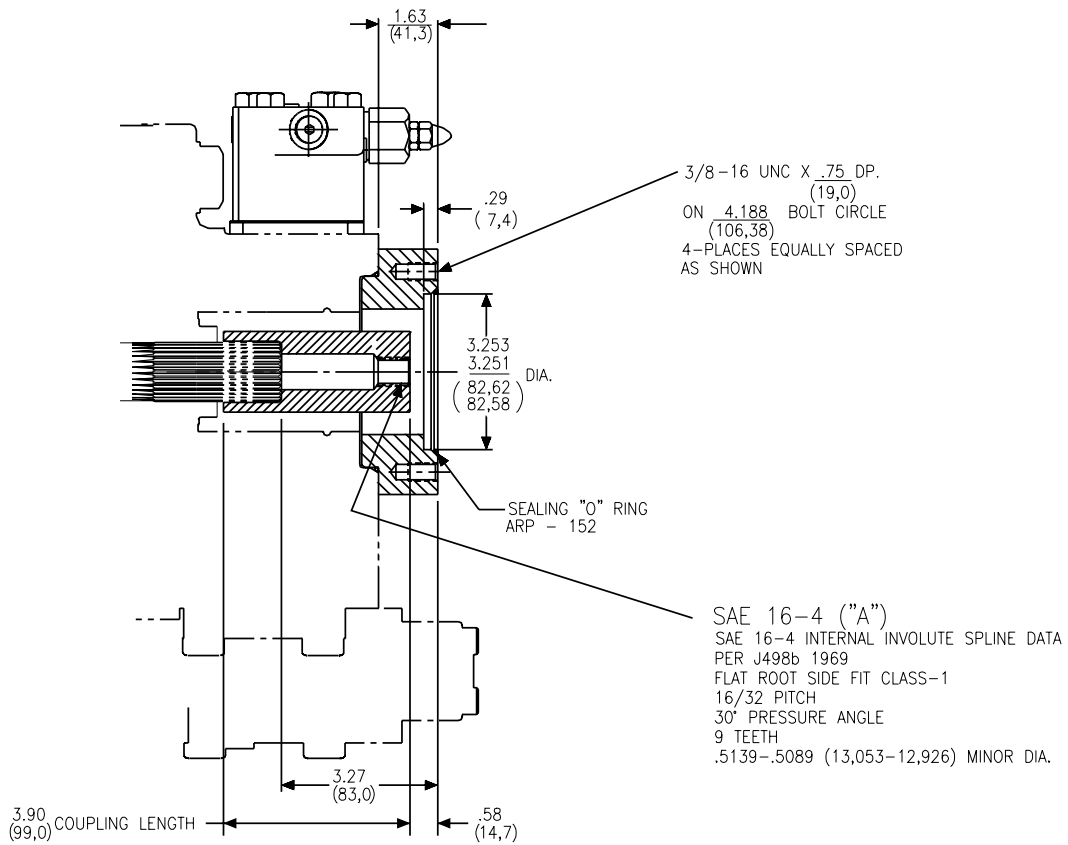

M11,14 R,L,M,N
P11,14 R,L
SAE 101-2 (B) WITH COUPLING 22-4
SAE 101-4 (B) WITH COUPLING 22-4

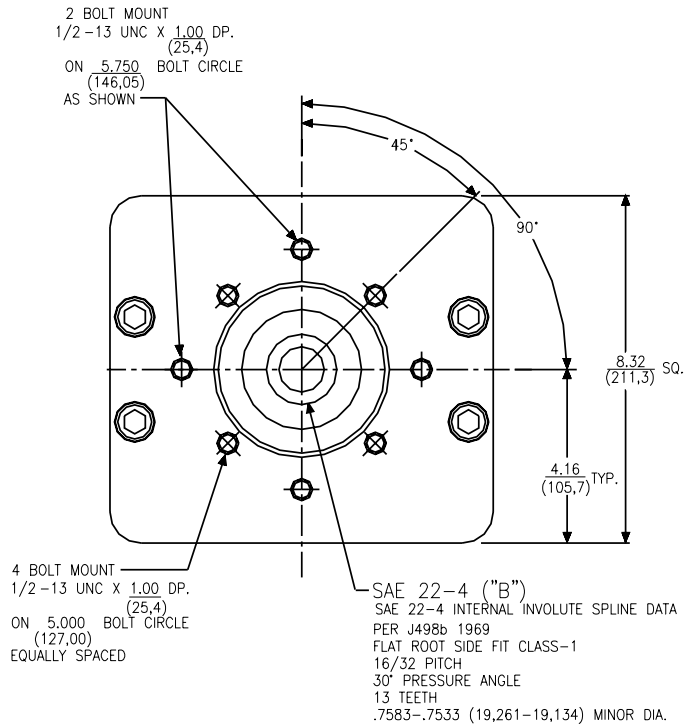
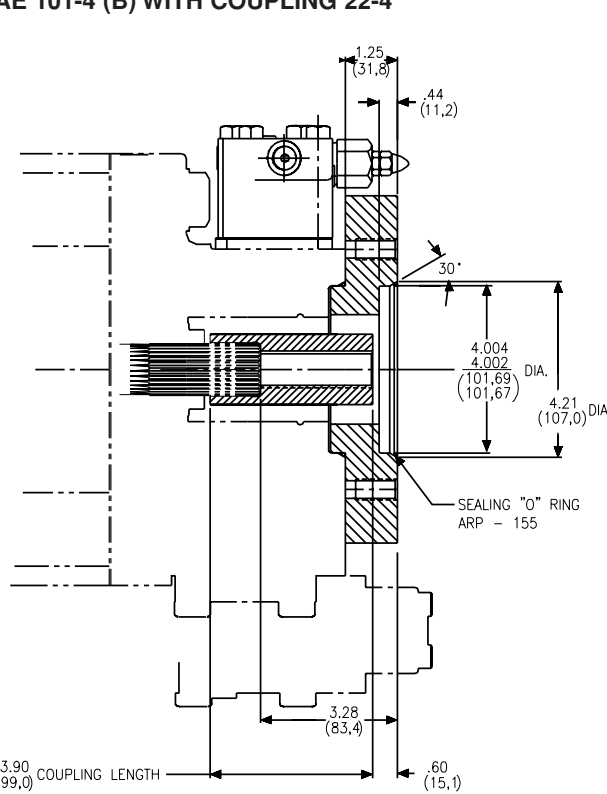

M11,14 R,L,M,N
P11,14 R,L
SAE 127-2 (C) WITH COUPLING 32-4
SAE 127-4 (C) WITH COUPLING 32-4

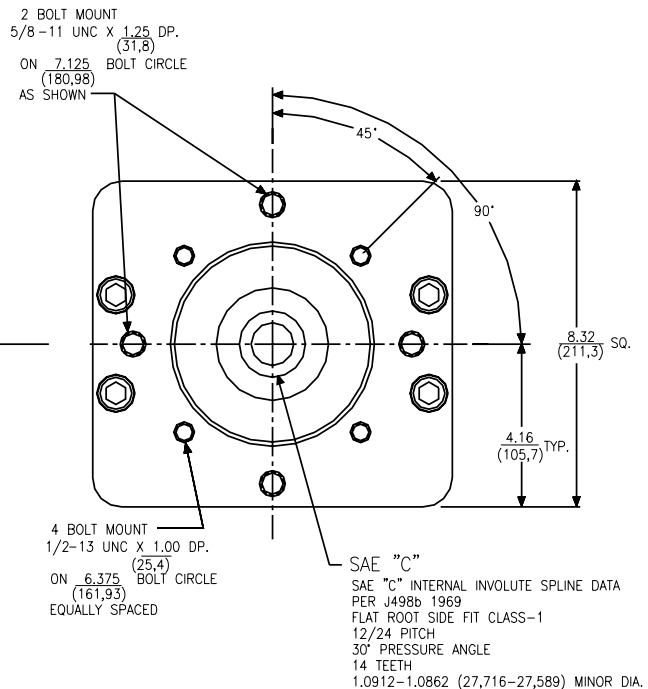
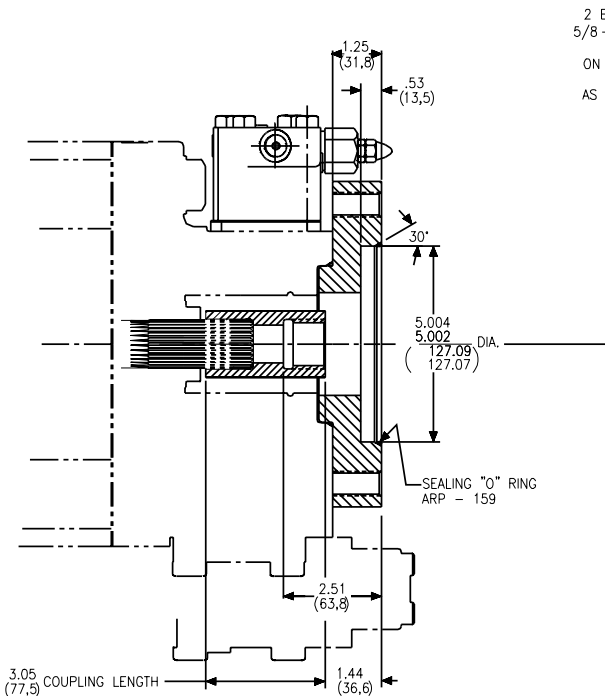

**M11,14 R,L,M,N
P11,14 R,L
SAE 152-4 (D) WITH COUPLING 44-4**

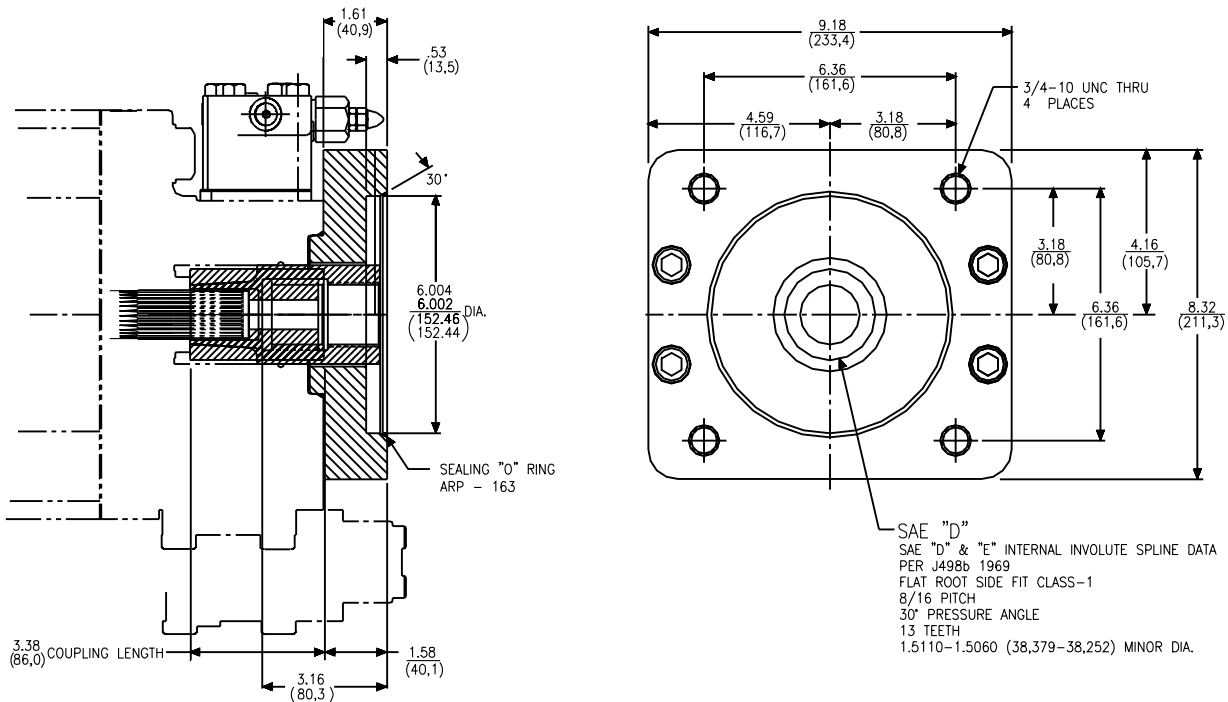

**M11,14 R,L,M,N
P11,14 R,L
SAE 165-4 (E) WITH COUPLING 44-4**

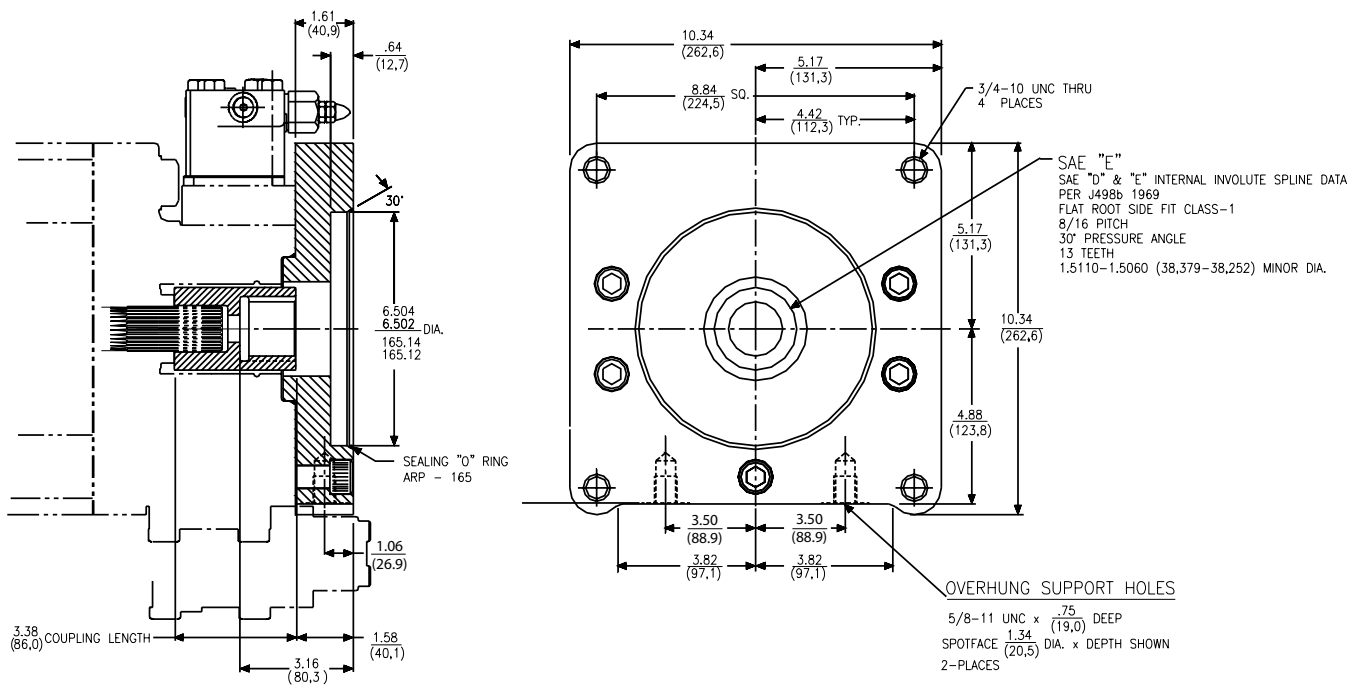

P24,30 P,S,X
SAE 101-2 (B) WITH COUPLING 22-4

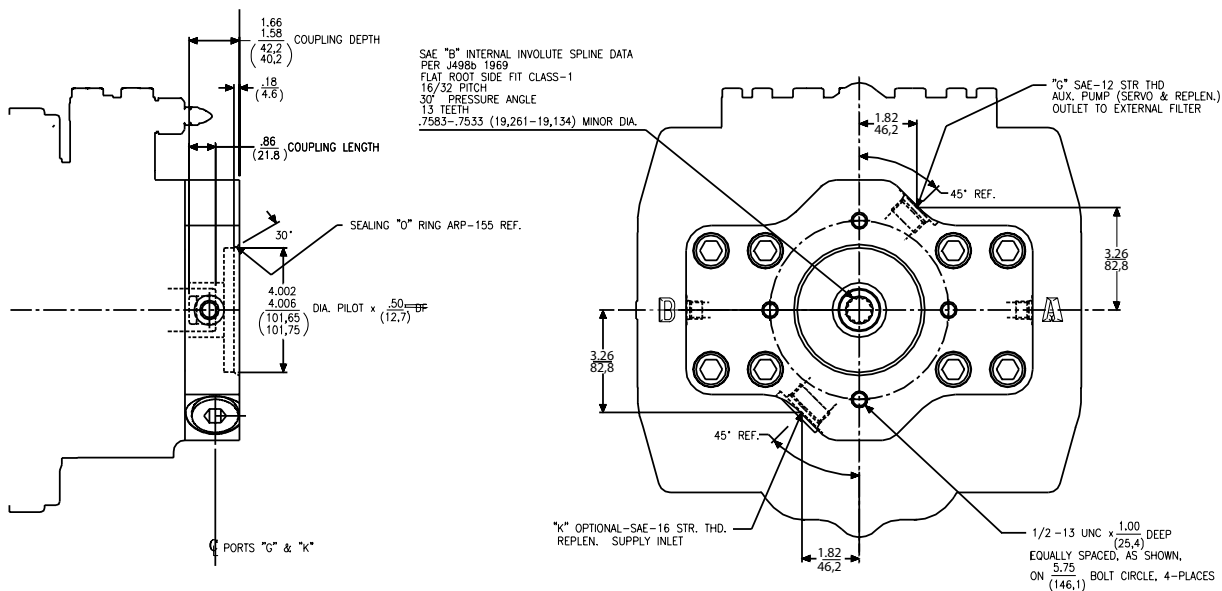

P24,30 P,S,X
SAE 127-2 (C) WITH COUPLING 32-4
SAE 127-4 (C) WITH COUPLING 32-4

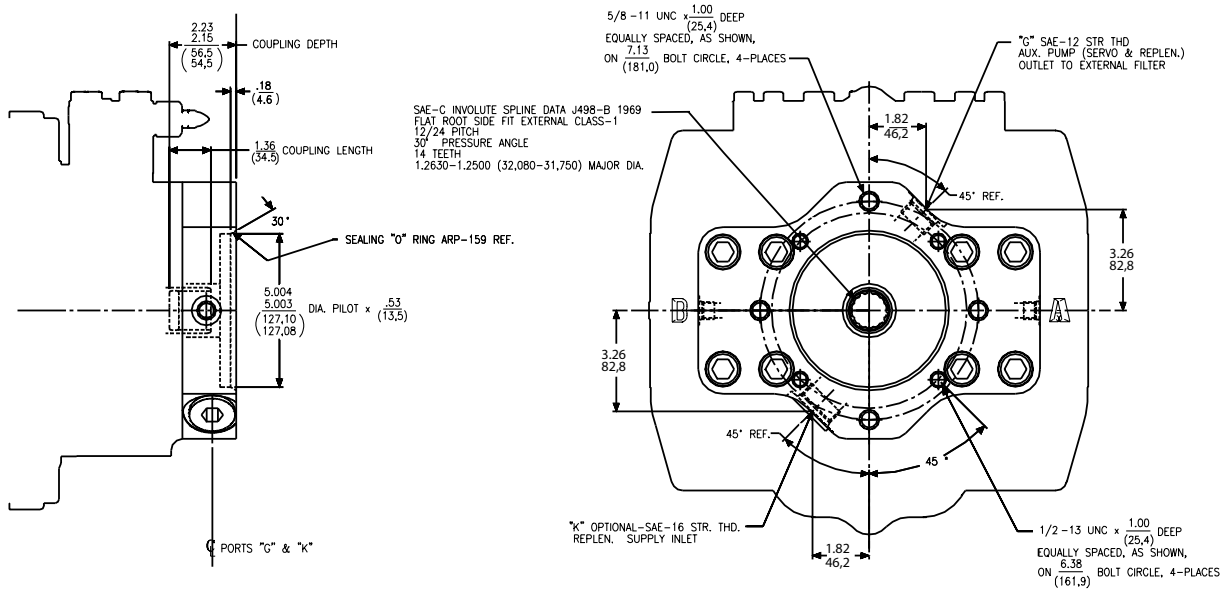

M24,30 R,L,M,N
P24,30 R,L
BLANKING PLATE

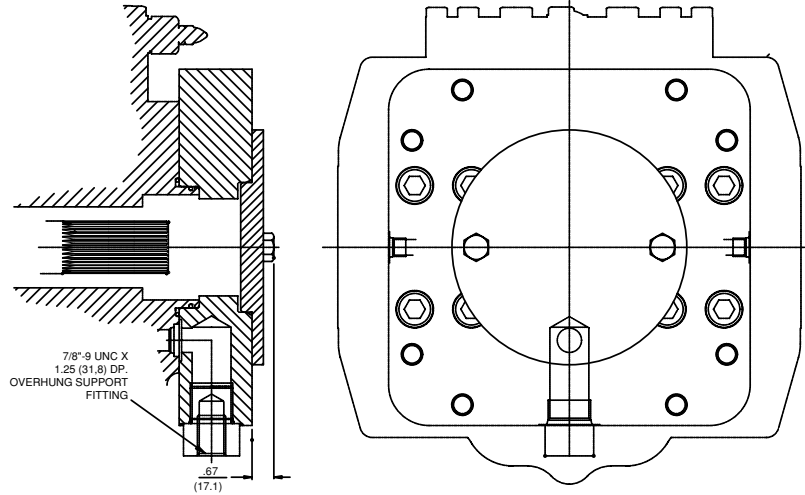

M24,30 R,L,M,N
P24,30 R,L
SAE 101-2 (B) WITH COUPLING 22-4
SAE 101-4 (B) WITH COUPLING 22-4

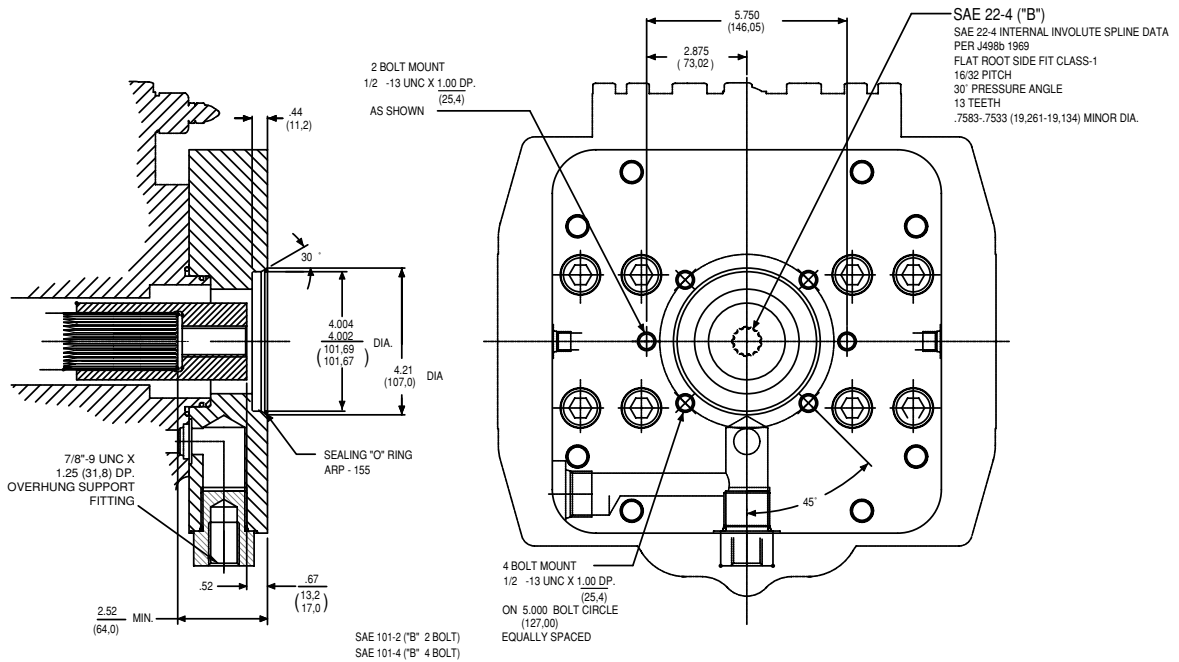

M24,30 R,L,M,N
P24,30 R,L
SAE 127-2 (C) WITH COUPLING 32-4
SAE 127-4 (C) WITH COUPLING 32-4

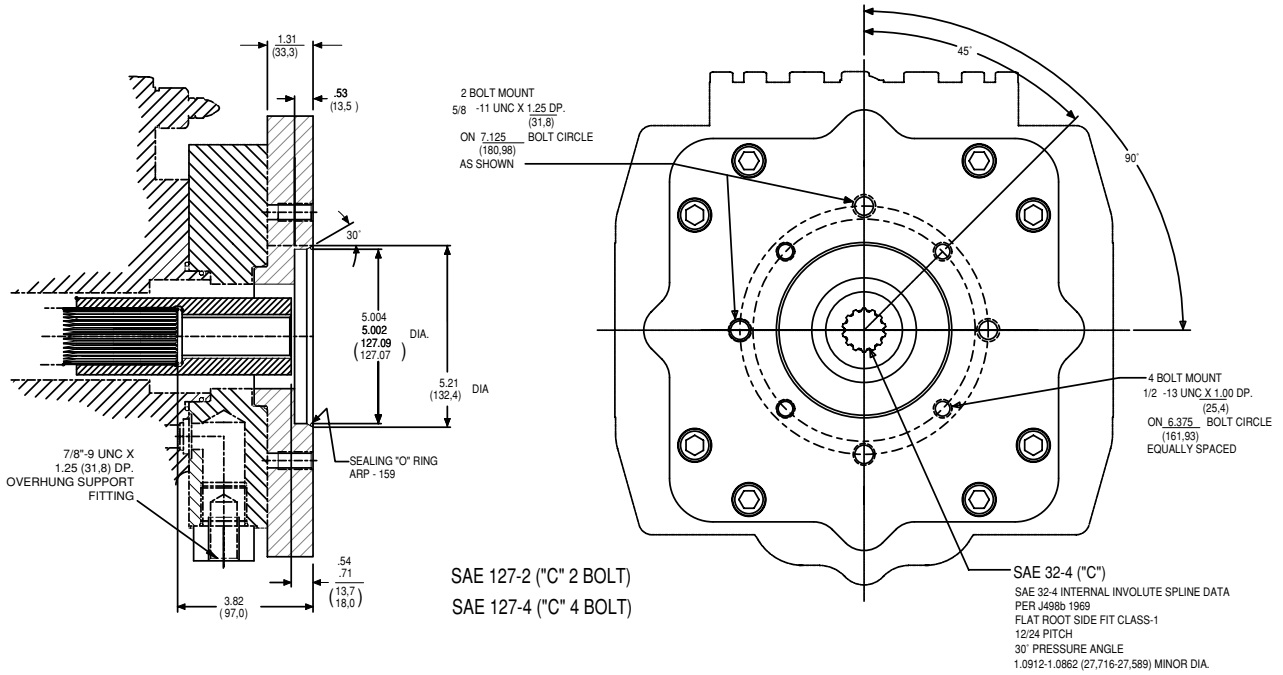

M24,30 R,L,M,N
P24,30 R,L
SAE 152-4 (D) WITH COUPLING 44-4

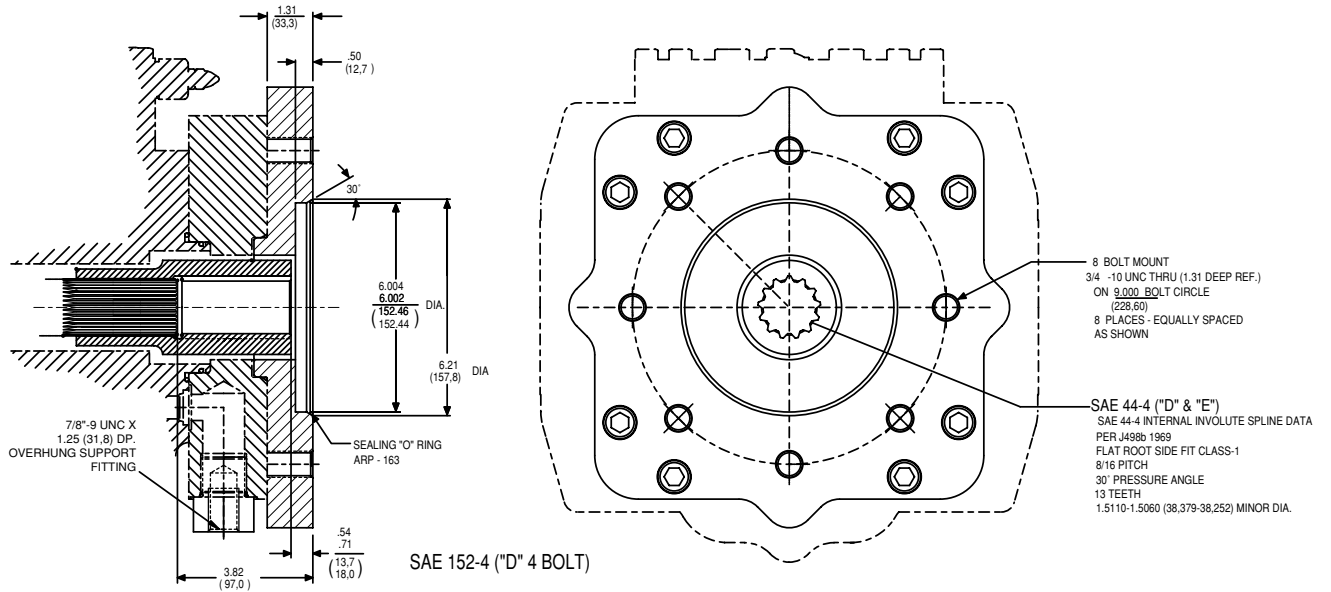

M24,30 R,L,M,N
P24,30 R,L
SAE 165-4 (E) WITH COUPLING 44-4

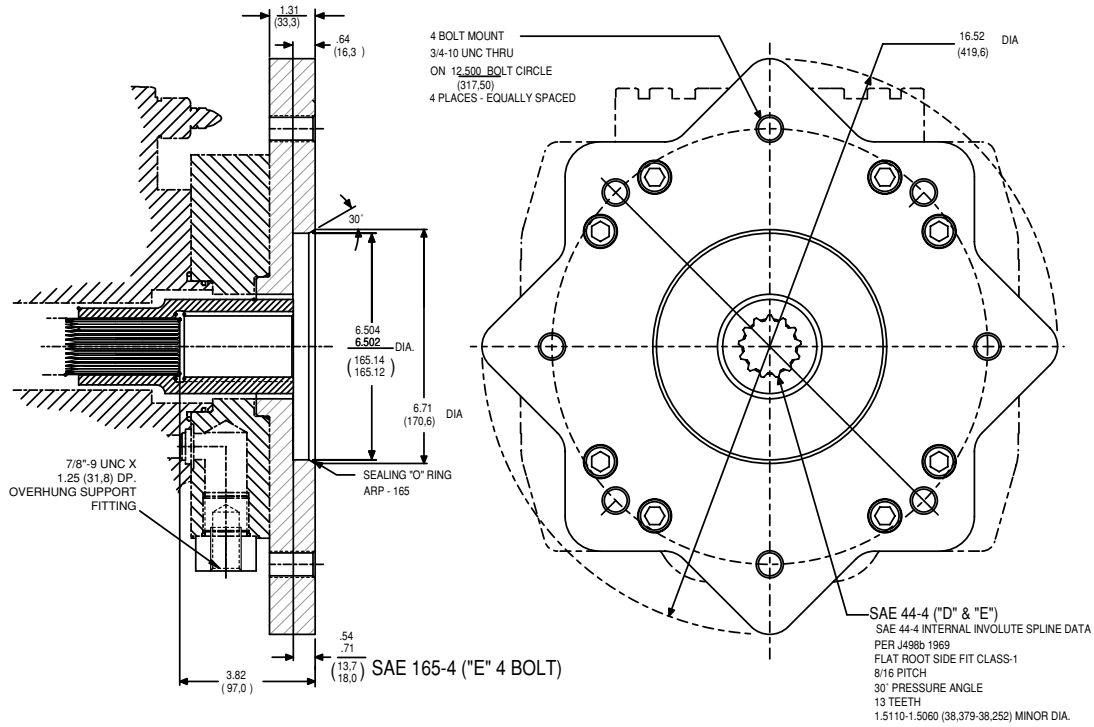

M24,30 R,L,M,N
P24,30 R,L
SAE 177-4 (F) WITH COUPLING 50-4

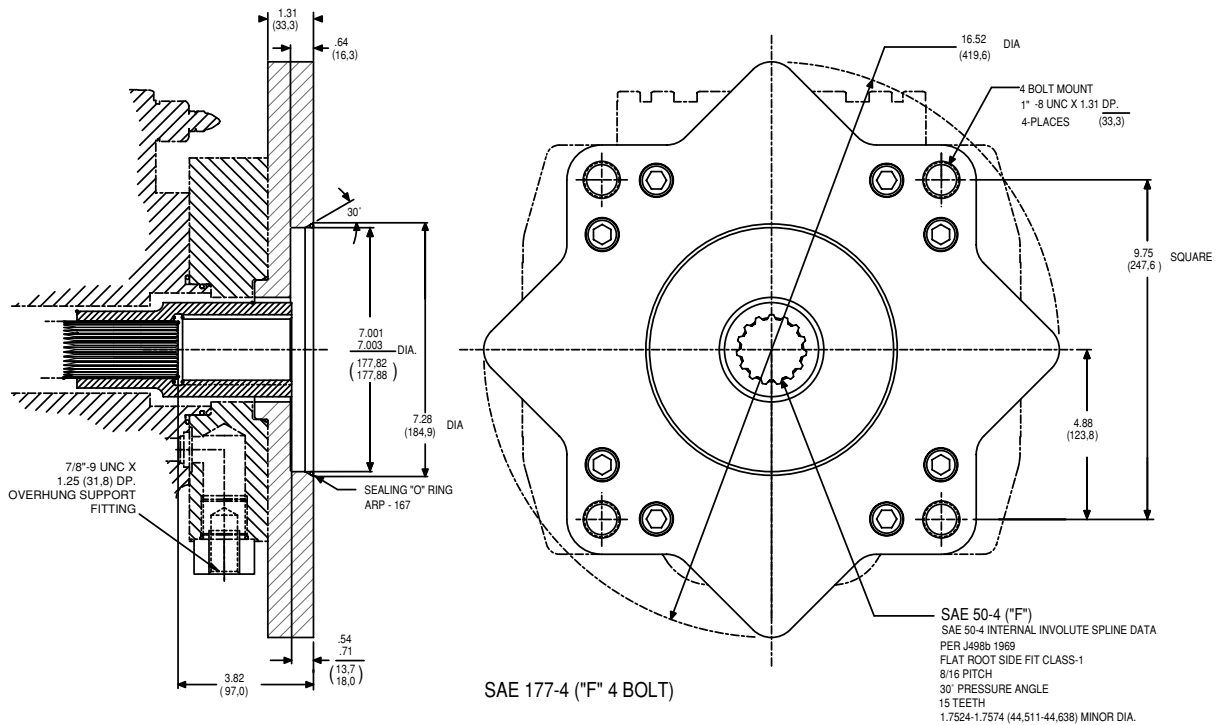

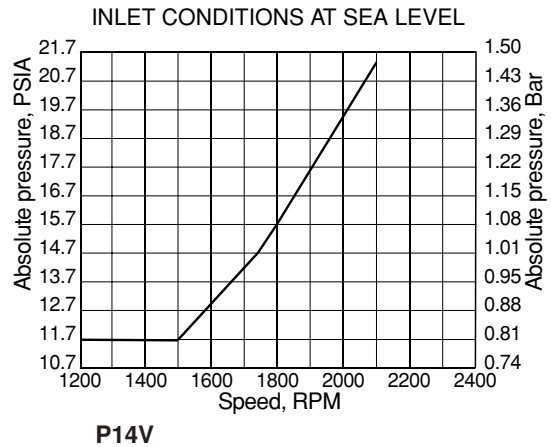
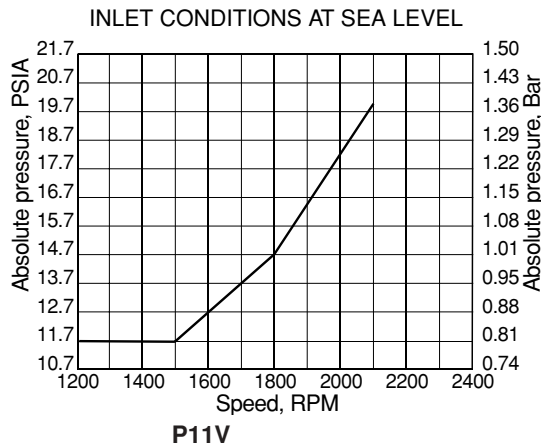
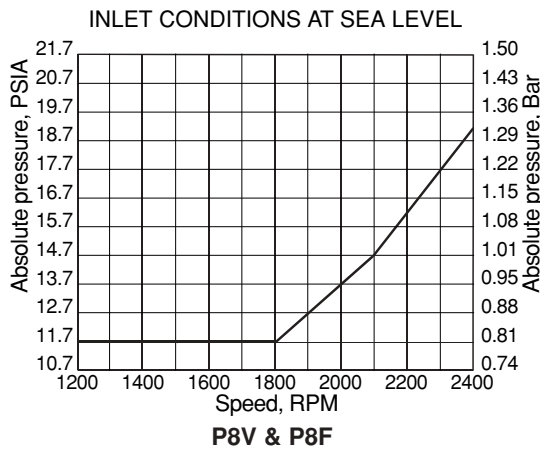
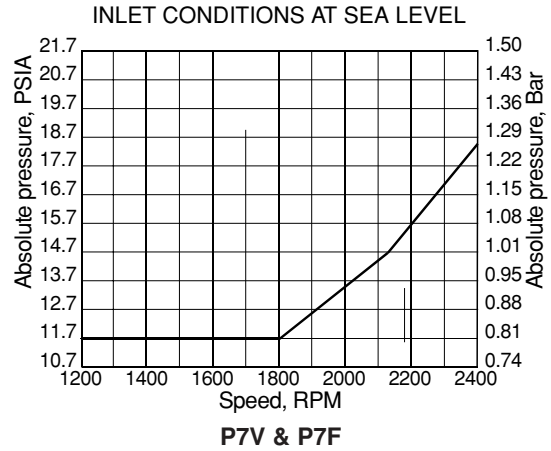
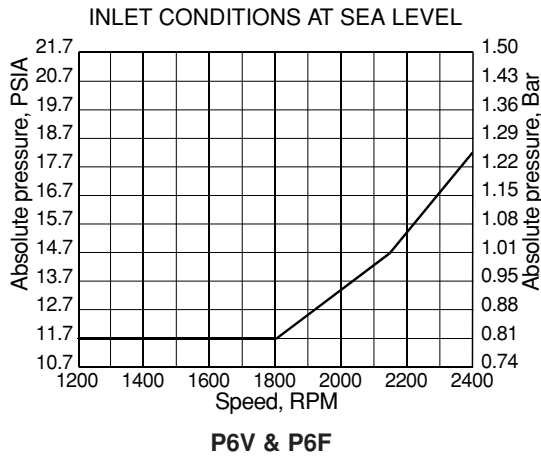

Note: The absolute inlet pressure is the pressure required to fill the pump with petroleum based fluids. The maximum pressure in the inlet port is 200 psi, 14 bar. For unboosted systems, the diameter of the suction line must be sized to allow a maximum velocity not higher than 4 ft/sec. A coarse screen may be considered in the suction line, no filter. For water in oil invert emulsions and water glycols increase the inlet absolute pressure by 25%, for phosphate ester increase the absolute inlet pressure by 35%. Any inlet pressures above atmospheric may increase noise levels and decrease efficiencies noted in this literature. Please consult your nearest Denison Office for further details.

Inlet characteristics-auxiliary pump, port C

Series	Speed rpm	Displacement		Pressure absolute	
		in ³ /rev	cm ³ /rev	psi	bar
6, 7, 8, 11, 14	1200	1.07	17,5	9.5	0,66
6, 7, 8, 11, 14	1800	1.07	17,5	9.5	0,66
6, 7, 8, 11, 14	2400	1.07	17,5	10.5	0,72
24, 30	1200	4.84	79,3	9.5	0,66
24, 30	1800	4.84	79,3	10.5	0,72

Note: Maximum pressure on inlet port C is 200 psi, 14 bar.

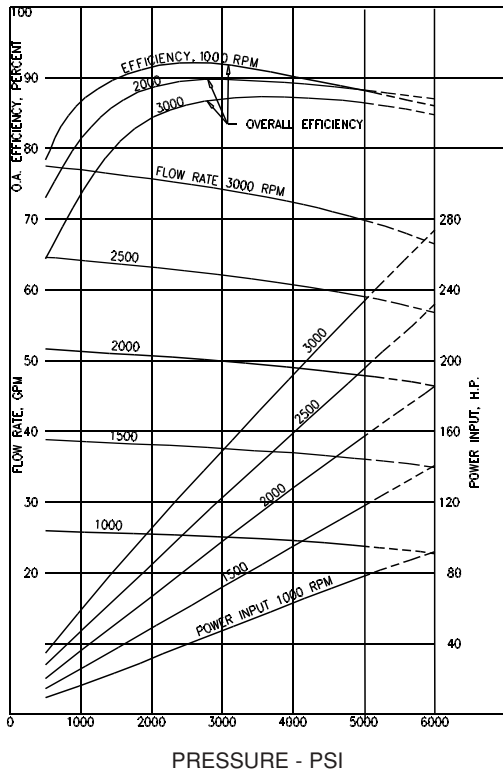

Performance curves Series 6 Pump at full displacement

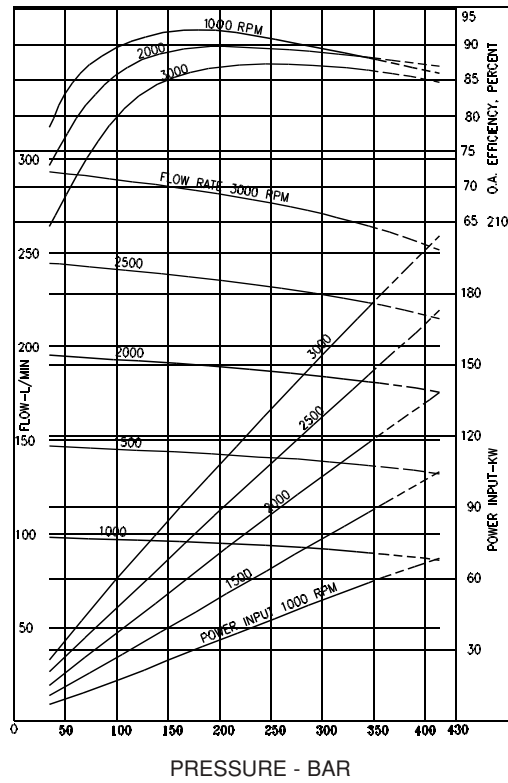

Performance curves Series 6 Pump at full displacement

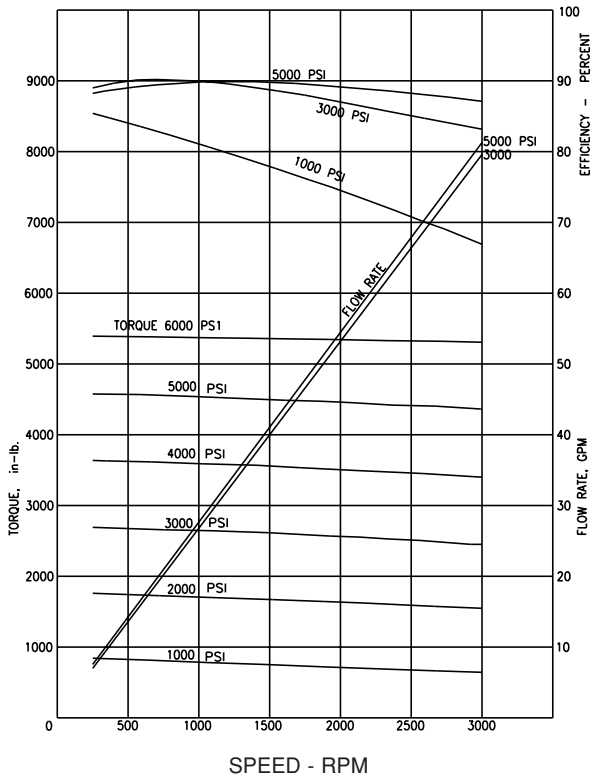

Performance curves Series 6 Motor at full displacement

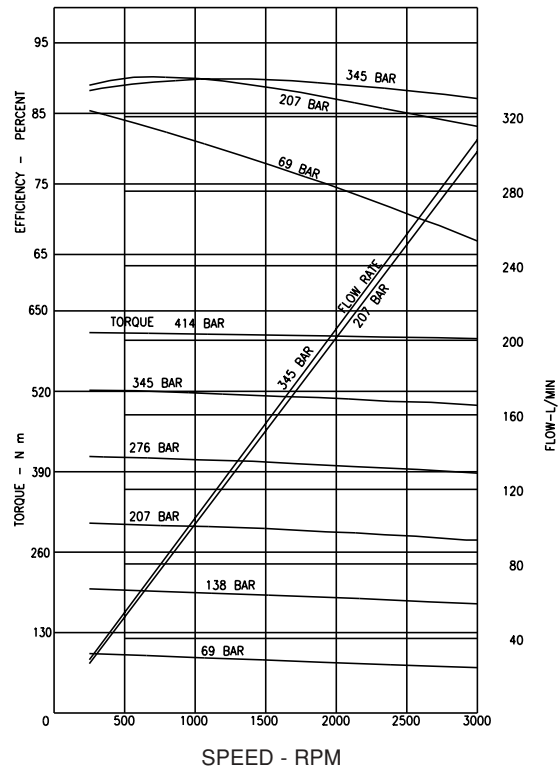

Performance curves Series 6 Motor at full displacement

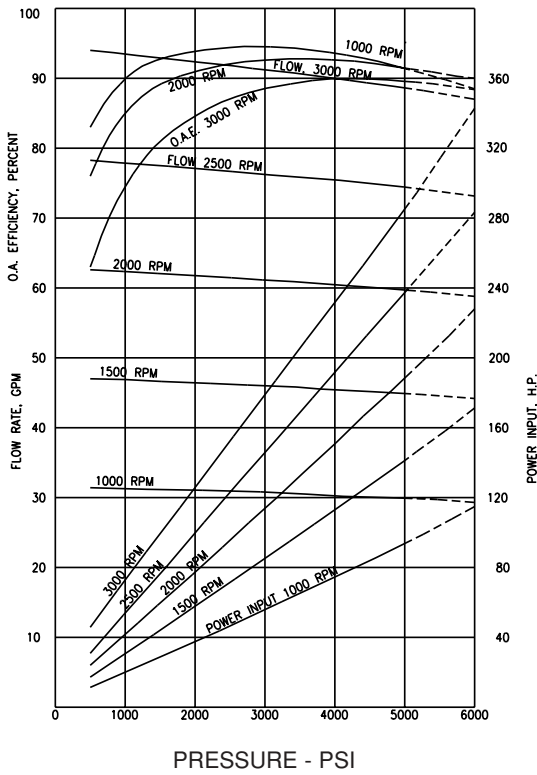

Performance curves Series 7 Pump at full displacement

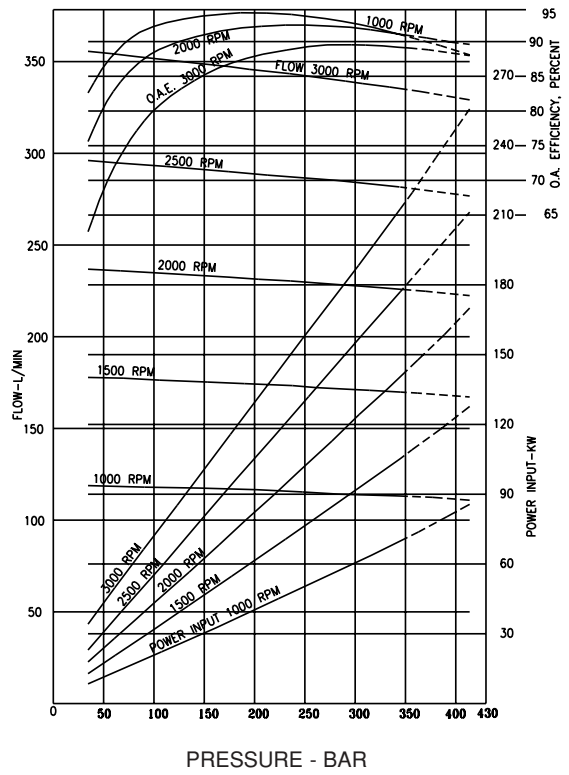

Performance curves Series 7 Pump at full displacement

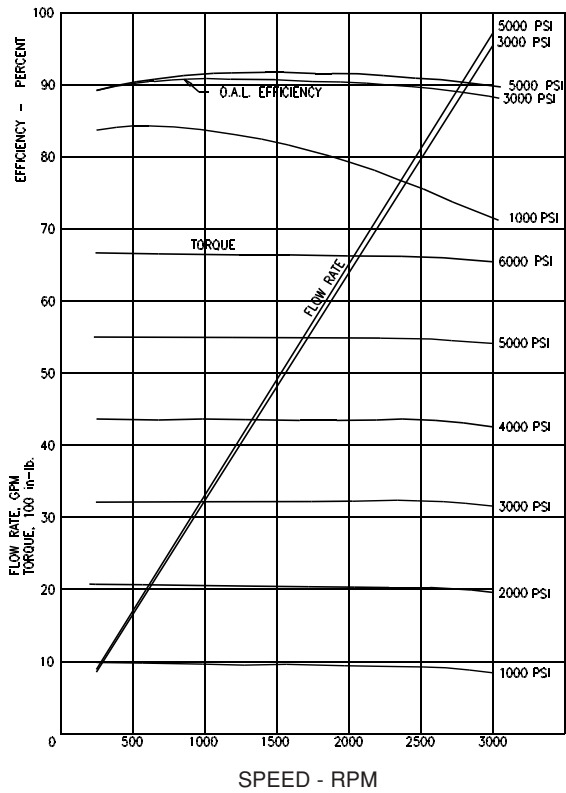

Performance curves Series 7 Motor at full displacement

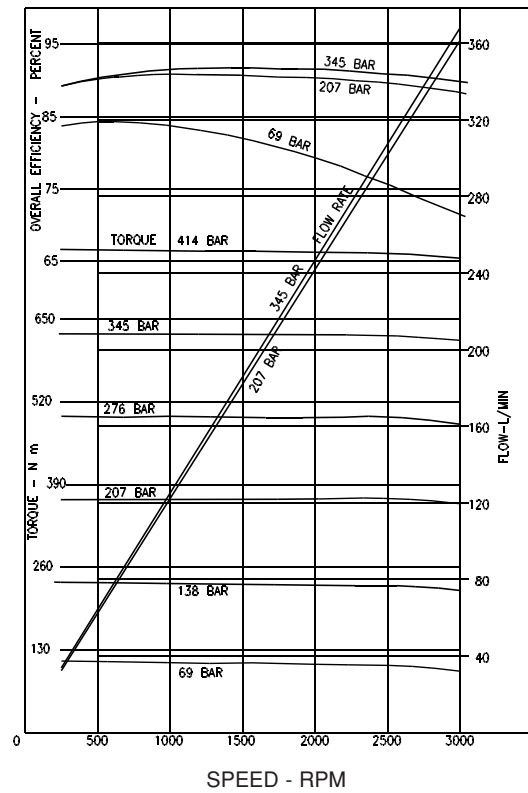

Performance curves Series 7 Motor at full displacement

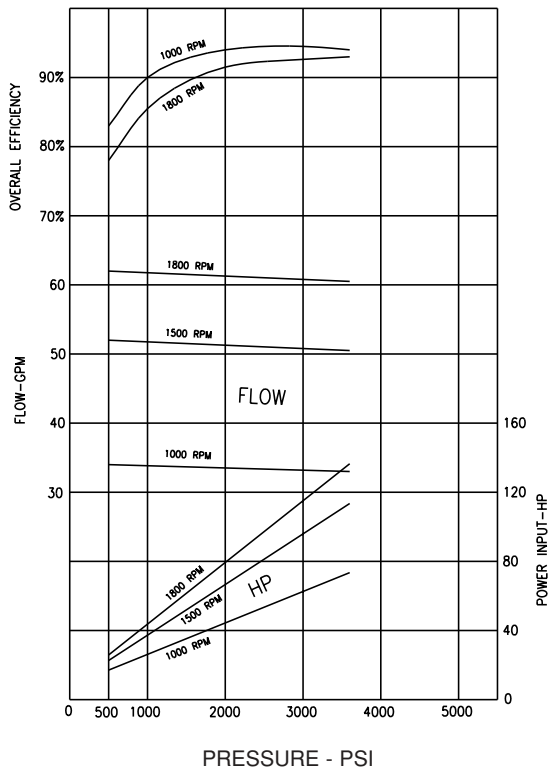

Performance curves Series 8
Pump at full displacement

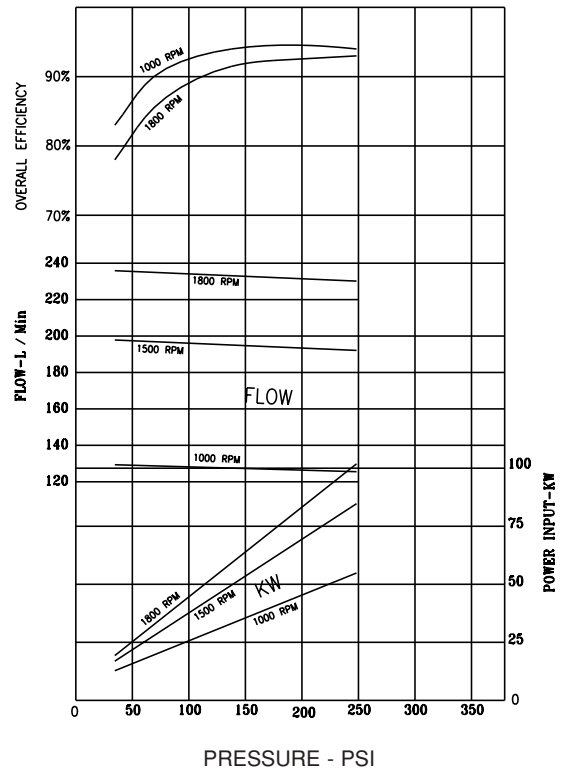

Performance curves Series 8
Pump at full displacement

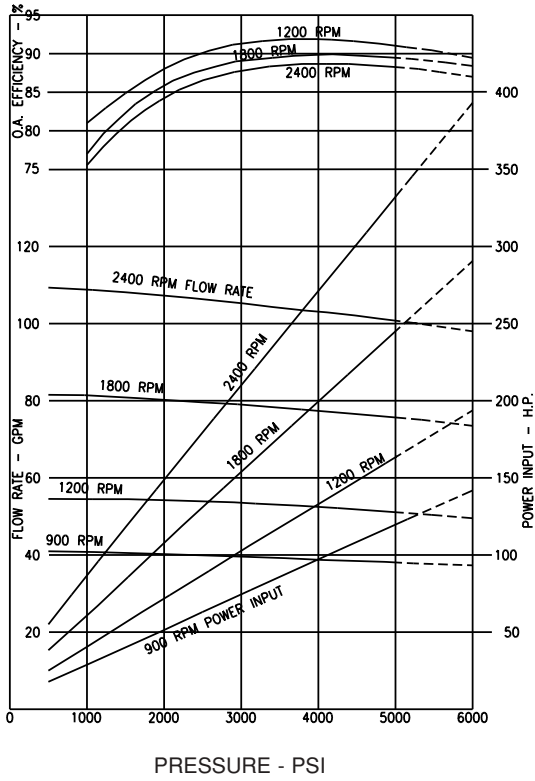

Performance curves Series 11
Pump at full displacement

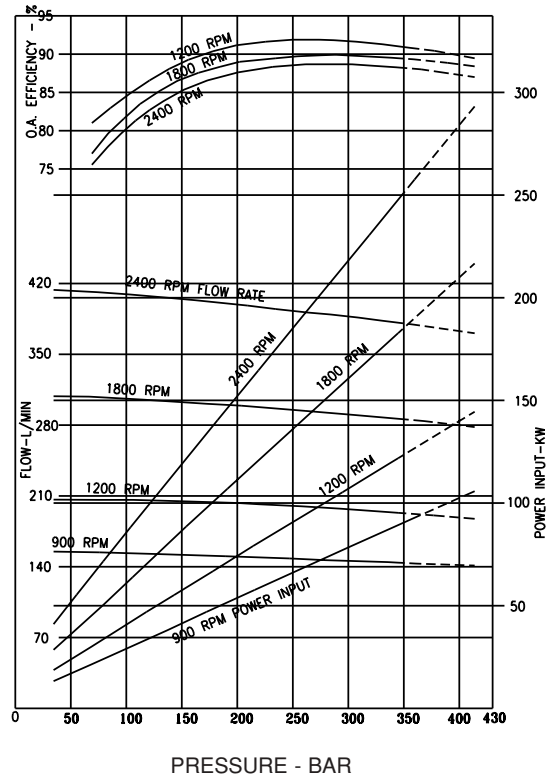

Performance curves Series 11
Pump at full displacement

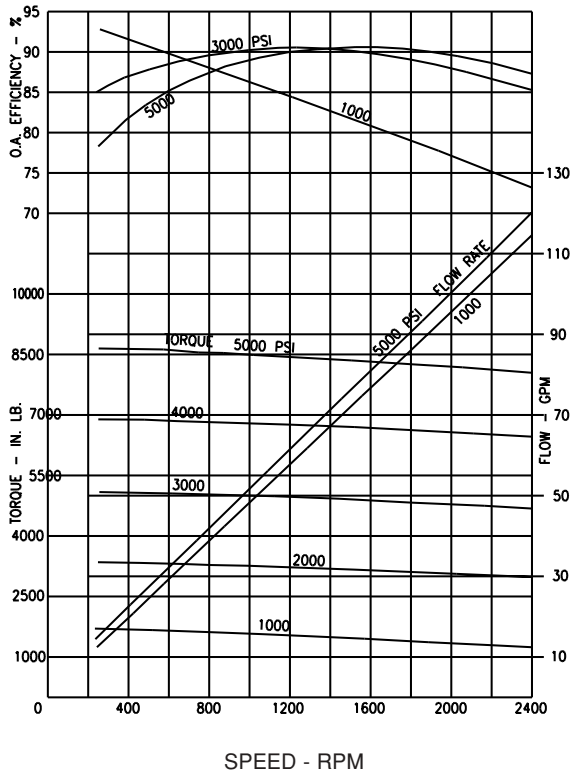

Performance curves Series 11
Motor at full displacement

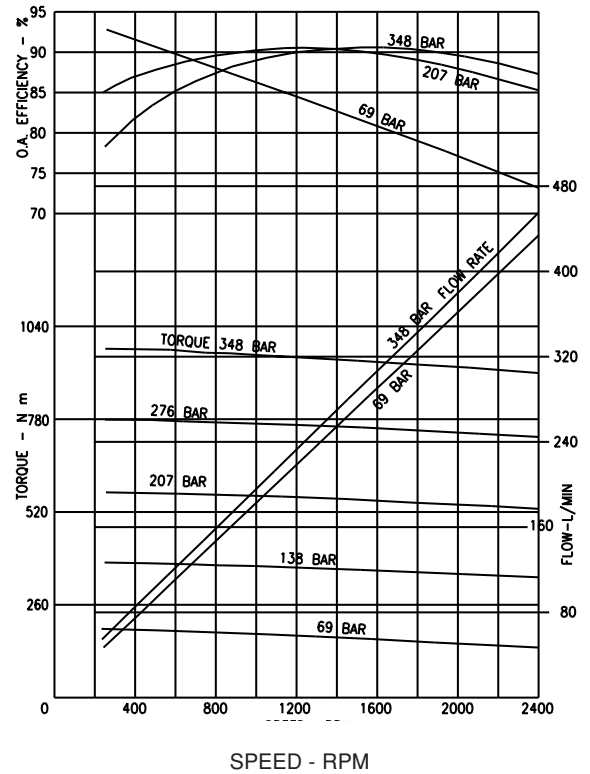

Performance curves Series 11
Motor at full displacement

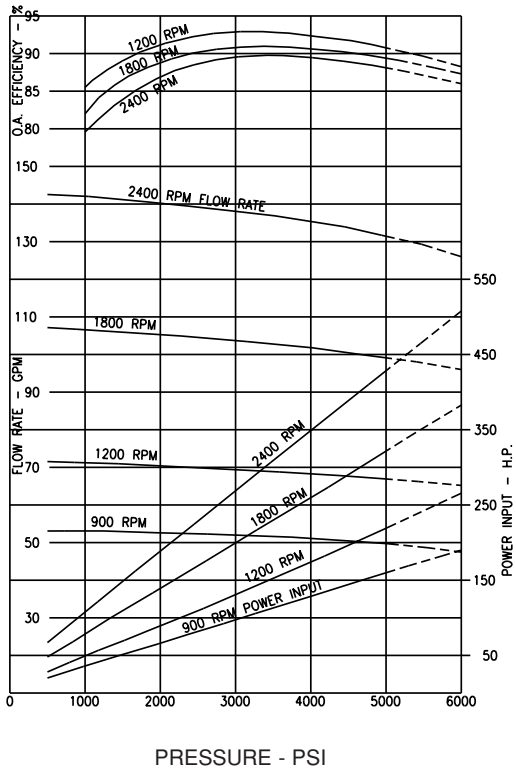

Performance curves Series 14
Pump at full displacement

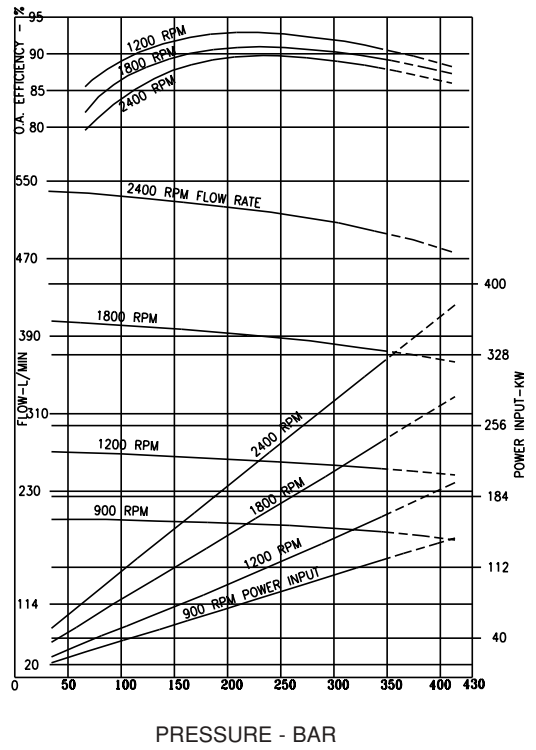

Performance curves Series 14
Pump at full displacement

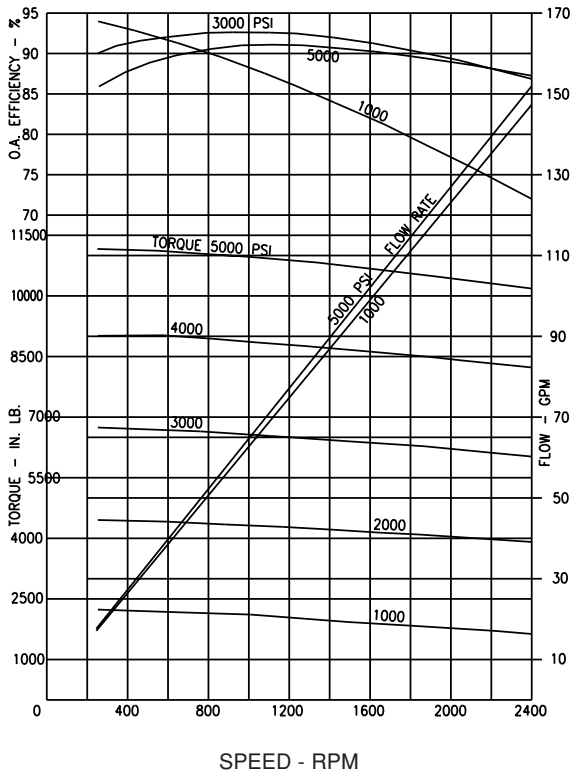

Performance curves Series 14
Motor at full displacement

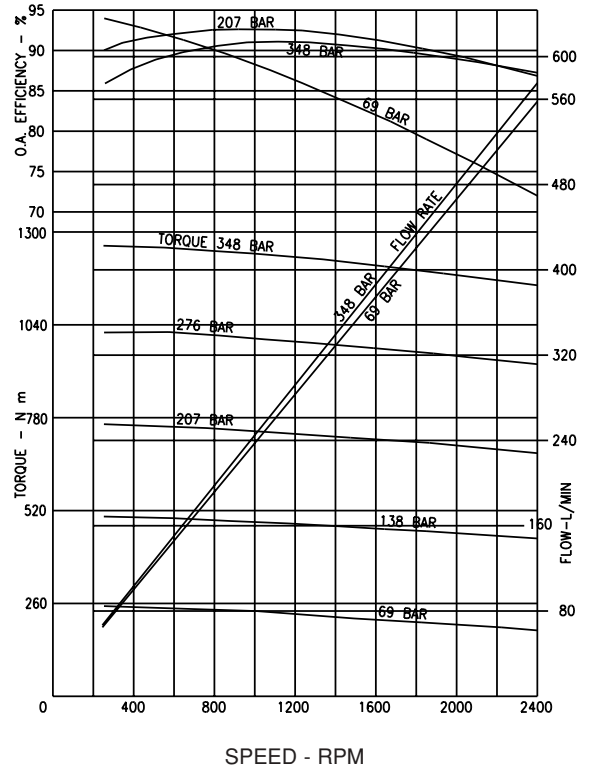

Performance curves Series 14
Motor at full displacement

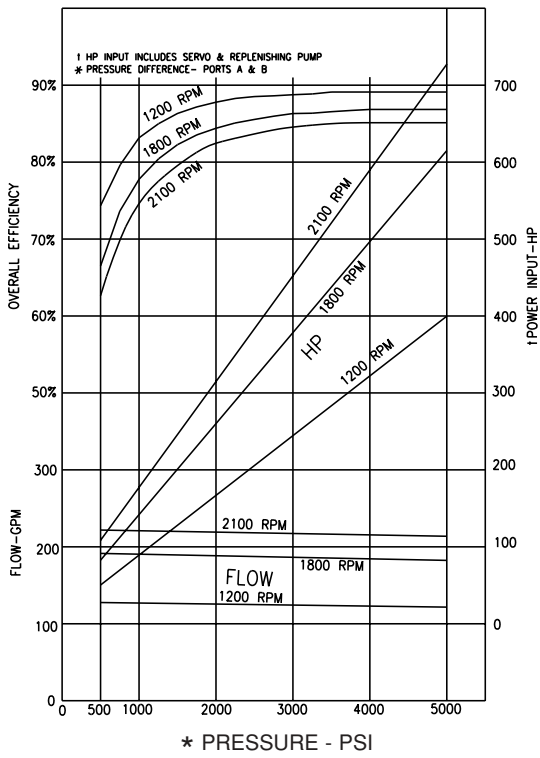

Performance curves Series 24
Pump at full displacement

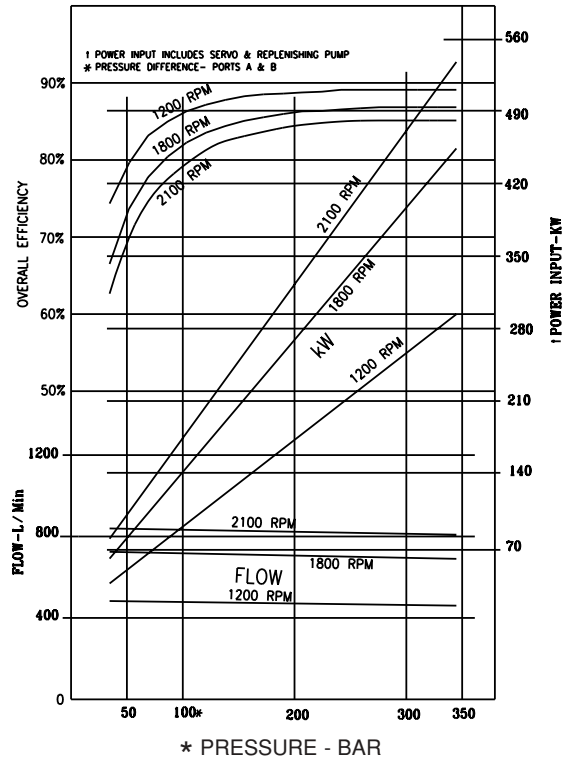

Performance curves Series 24
Pump at full displacement

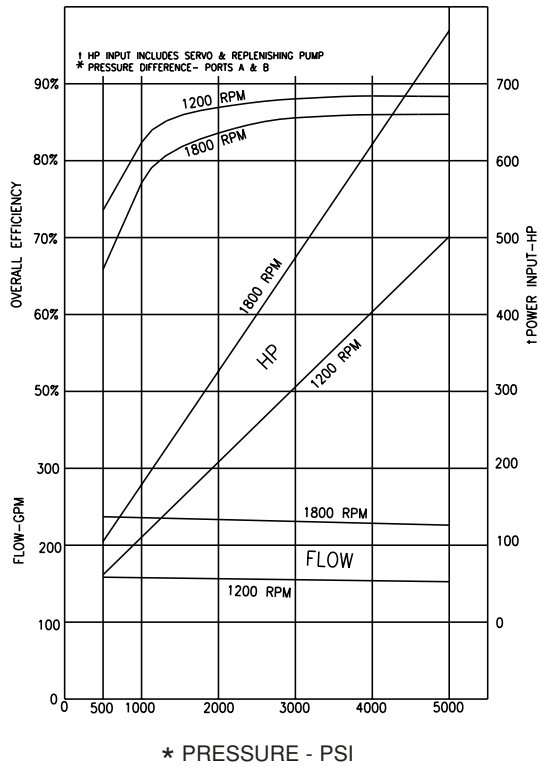

Performance curves Series 30
Pump at full displacement

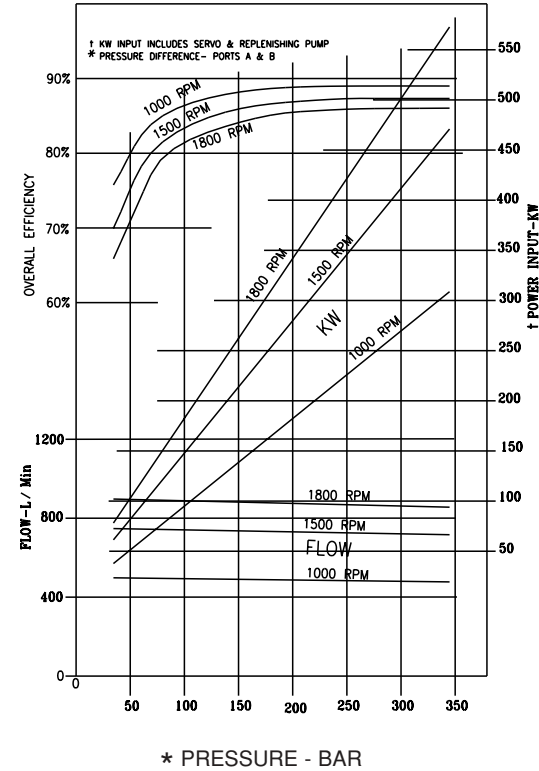

Performance curves Series 30
Pump at full displacement

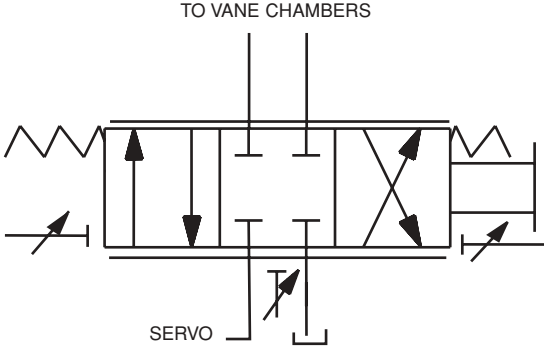
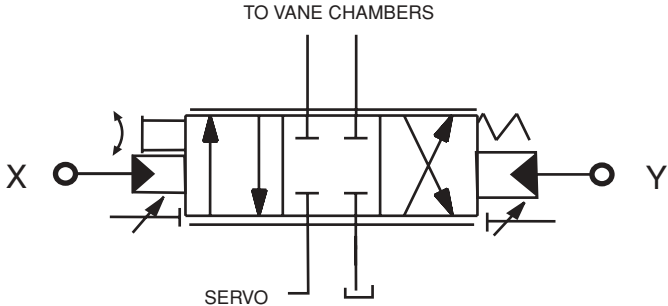
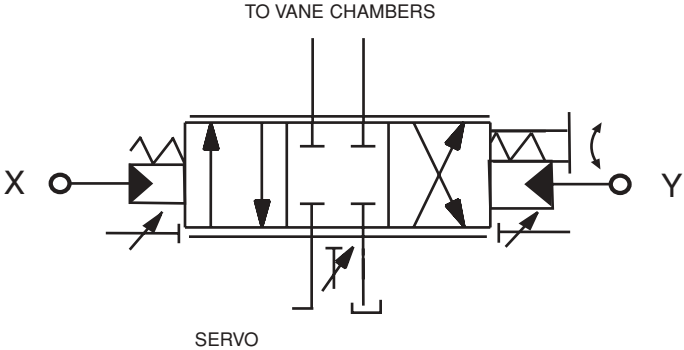
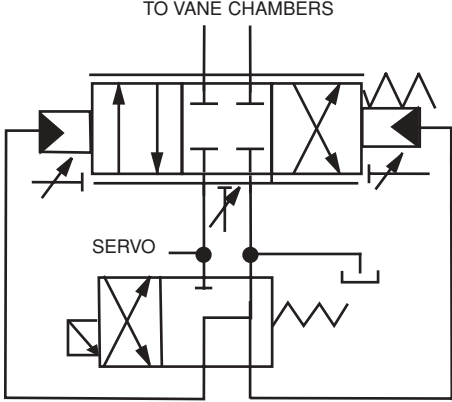
CODE	DESCRIPTION	HYDRAULIC CIRCUIT
10	MANUAL SCREW ADJUST	
2A	TWO POSITION CONTROL	
2H	3 POSITION CONTROL	
2M	2 POSITION CONTROL WITH 4DO1 VALVE	

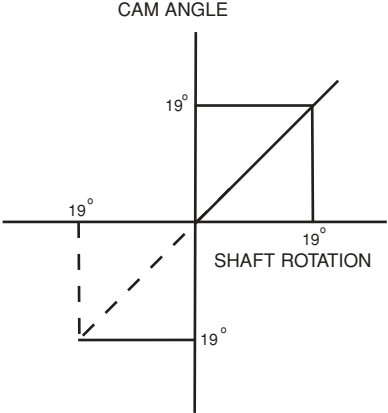
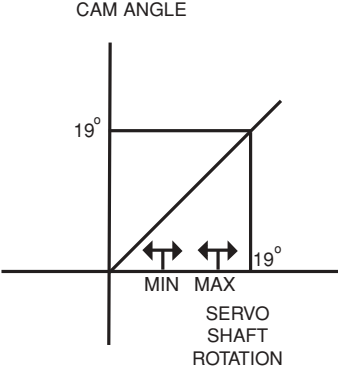
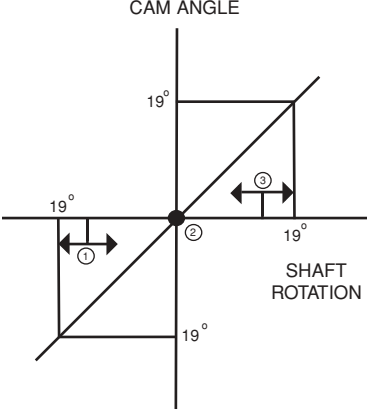
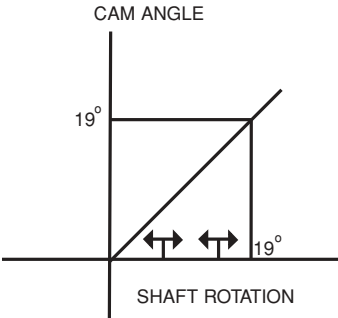
TYPICAL PERFORMANCE	DESCRIPTION OF OPERATION
 <p>The graph plots CAM ANGLE on the vertical axis against SHAFT ROTATION on the horizontal axis. A solid line starts at the origin (0,0) and rises linearly to a point where the angle is 19°. From this point, a horizontal line extends to the right, also labeled 19°. A dashed line continues the linear slope from the origin into the negative quadrant, reaching a 19° angle in the negative direction. Vertical and horizontal dashed lines indicate the 19° coordinates for both the positive and negative linear segments.</p>	<p>Spring loaded toward maximum displacement, with an adjustment screw to limit the displacement anywhere between 0% and 100%. A minimum volume stop is also supplied so that when the rotary servo shaft is turned, the displacement can be varied only between the minimum and maximum settings.</p> <p>Torque required to rotate servo shaft: 20 lb-in, 2.56 Nm.</p>
 <p>The graph plots CAM ANGLE on the vertical axis against SERVO SHAFT ROTATION on the horizontal axis. A solid line starts at the origin (0,0) and rises linearly to a point where the angle is 19°. From this point, a horizontal line extends to the right, also labeled 19°. Two horizontal double-headed arrows, labeled 'MIN' and 'MAX', are positioned below the horizontal segment, indicating adjustable displacement limits.</p>	<p>Hydraulically piloted non-proportionally between adjustable minimum and maximum displacements. The control is spring loaded toward minimum when used on pumps, to maximum on motors. Servo pressure is switched by an external valve to drive the control in either direction. When used on motors, the minimum setting can be set no lower than 30% of maximum.</p>
 <p>The graph plots CAM ANGLE on the vertical axis against SHAFT ROTATION on the horizontal axis. A solid line starts at the origin (0,0) and rises linearly to a point where the angle is 19°. From this point, a horizontal line extends to the right, also labeled 19°. Three horizontal double-headed arrows, labeled 1, 2, and 3, are positioned below the horizontal segment, indicating three different adjustable displacement limits.</p>	<p>Hydraulically piloted non-proportionally between an adjustable minimum displacement of $0 \pm 5\%$ and two fully adjustable maximum displacements, one in either direction, and spring loaded toward minimum. Servo pressure is switched by an external valve to drive the control in either direction.</p>
 <p>The graph plots CAM ANGLE on the vertical axis against SHAFT ROTATION on the horizontal axis. A solid line starts at the origin (0,0) and rises linearly to a point where the angle is 19°. From this point, a horizontal line extends to the right, also labeled 19°. Two horizontal double-headed arrows, labeled 'MIN' and 'MAX', are positioned below the horizontal segment, indicating adjustable displacement limits.</p>	<p>Same as 2A except a 4D01 two position directional valve is mounted to the control. With the solenoid de-energized, the control is spring loaded to zero for pumps and to maximum displacement for motors. Energizing the solenoid drives the control toward maximum displacement on pumps, minimum on motors. When used on motors, the minimum settings can be no less than 30% of maximum.</p>

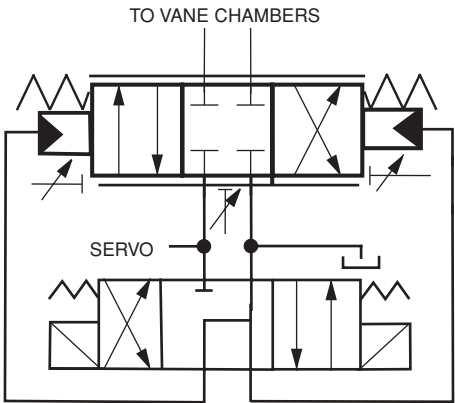
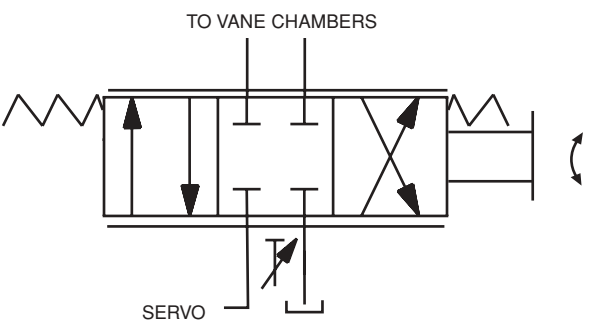
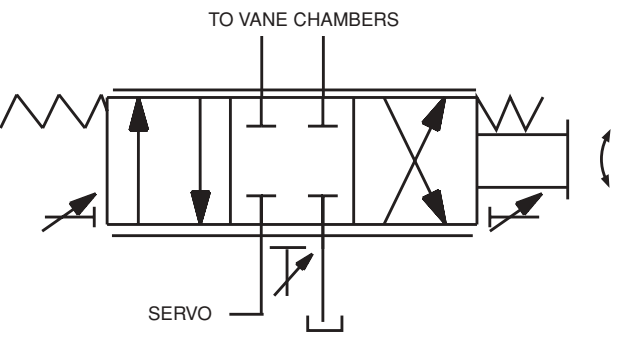
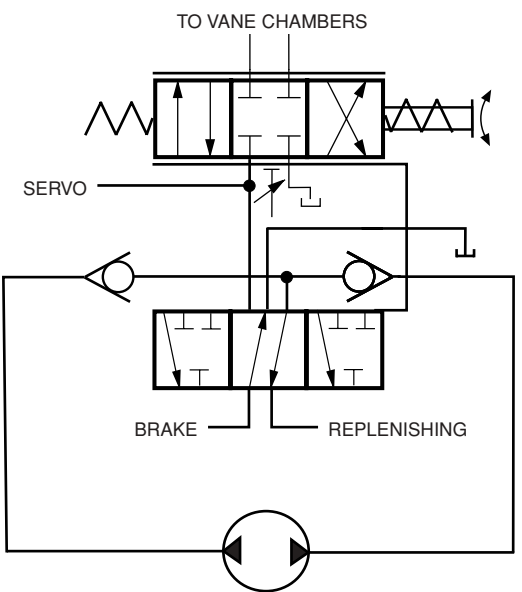
CODE	DESCRIPTION	HYDRAULIC CIRCUIT
2N	3 POSITION CONTROL WITH 4DO1 VALVE	 <p>TO VANE CHAMBERS</p> <p>SERVO</p>
40	SPRING CENTERED ROTARY SERVO	 <p>TO VANE CHAMBERS</p> <p>SERVO</p>
4A	SPRING CENTERED ROTARY SERVO WITH ADJUSTABLE STOPS	 <p>TO VANE CHAMBERS</p> <p>SERVO</p>
4B	SPRING CENTERED ROTARY SERVO WITH AUTOMATIC BRAKE AND BYPASS CONTROL	 <p>TO VANE CHAMBERS</p> <p>SERVO</p> <p>BRAKE</p> <p>REPLENISHING</p>

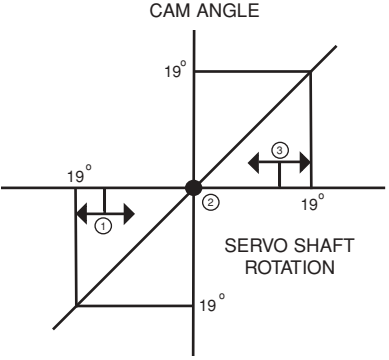
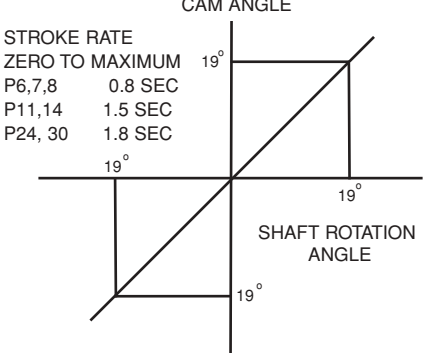
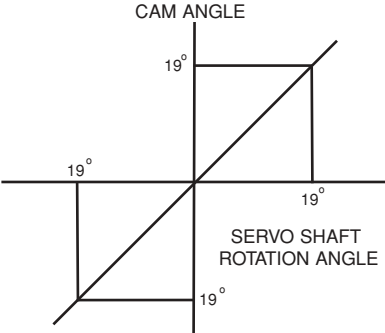
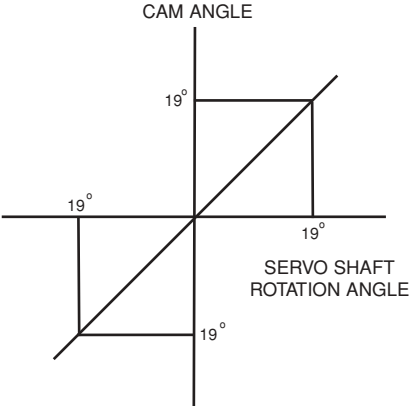
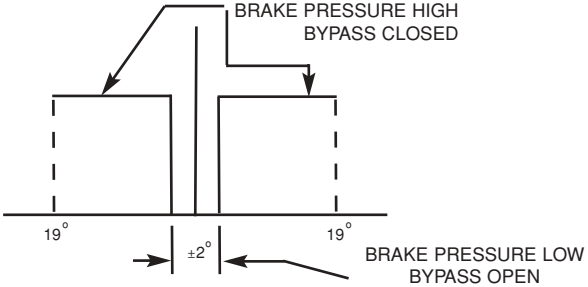
TYPICAL PERFORMANCE	DESCRIPTION OF OPERATION						
	<p>Same as 2H except a 4D01 three position directional valve is mounted to the control. With the solenoids de-energized, the control is spring loaded to zero. Energizing a solenoid drives the control toward maximum displacement in one of the two directions.</p>						
 <p>STROKE RATE ZERO TO MAXIMUM</p> <table border="1"> <tr> <td>P6,7,8</td> <td>0.8 SEC</td> </tr> <tr> <td>P11,14</td> <td>1.5 SEC</td> </tr> <tr> <td>P24, 30</td> <td>1.8 SEC</td> </tr> </table>	P6,7,8	0.8 SEC	P11,14	1.5 SEC	P24, 30	1.8 SEC	<p>The 40 is the basic displacement control for all Goldcup. It is actuated by a servo shaft that is rotated from 0° - 19°, either side of center. This action opens a unique slide valve to port servo oil to and from the vane chambers that actuate the rocker cam. Vanes, integral to the cam, move the cam so that it follows the rotary servo input shaft motion exactly. When the cam reaches the position equal to that of the input shaft, the slide valve closes. Any cam motion due to pumping forces immediately opens the slide valve to correct the cam position.</p> <p>Springs cause the control to return to zero stroke when no external force is applied to the servo shaft. An adjustment is provided to locate the exact zero position, to prevent machine creep.</p>
P6,7,8	0.8 SEC						
P11,14	1.5 SEC						
P24, 30	1.8 SEC						
	<p>The 4A control is the same as the 40, with addition of adjustable maximum volume stop screws, with locking caps, to limit the control to less than 100% displacement. Stops are present on both sides of center and may be set independently to different settings.</p>						
<p>The 4B control is the same as the 4A control, with the addition of an output port that will provide servo pressure to control a spring applied, pressure released parking brake. The control contains anticoincidence functions that cause the brake to release immediately upon</p> 	<p>application of an on-stroke motion at the rotary servo shaft, and that cause the brake to remain released even after the rotary servo shaft is recentered, until the pump rocker cam actually returns to zero, at which time the brake will set. Additionally, a small bypass is opened between the pump A & B ports to bypass any flow that is generated if the pump is not exactly zeroed. The bypass closes whenever the brake is released.</p> 						

CODE	DESCRIPTION	HYDRAULIC CIRCUIT
<p>4C</p>	<p>SPRING CENTERED BRAKE AND ADJUSTABLE BYPASS CONTROL (AUTOMATIC BRAKE CONTROL)</p>	
<p>5A</p>	<p>ELECTRO HYDRAULIC CONTROL</p>	
<p>8A</p>	<p>HYDRAULIC STROKER</p>	

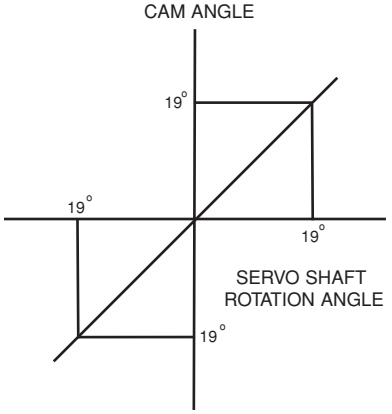
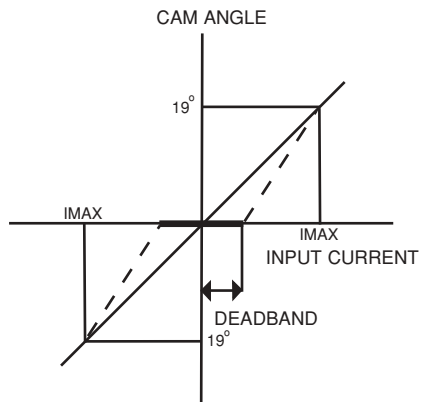
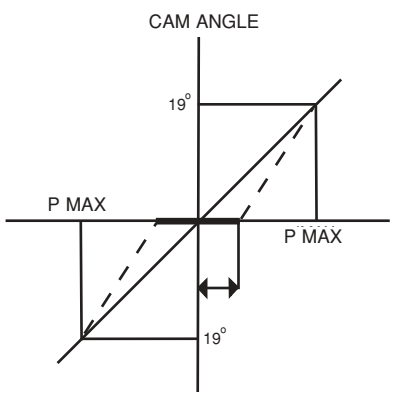
TYPICAL PERFORMANCE	DESCRIPTION OF OPERATION
 <p>The graph plots CAM ANGLE on the vertical axis against SERVO SHAFT ROTATION ANGLE on the horizontal axis. A solid diagonal line represents the ideal 1:1 relationship. A horizontal line is drawn at a CAM ANGLE of 19°. Vertical lines from the intersection of this horizontal line and the diagonal line drop to the horizontal axis, marking 19° on both sides of the origin. This indicates a 19° deadband where the cam angle is zero despite servo shaft rotation.</p>	<p>This control combines the features of the 4A and 4B controls. See above descriptions.</p>
 <p>The graph plots CAM ANGLE on the vertical axis against INPUT CURRENT on the horizontal axis. A dashed diagonal line represents the ideal relationship. A horizontal line is drawn at a CAM ANGLE of 19°. Vertical lines from the intersection of this horizontal line and the dashed line drop to the horizontal axis, marking IMAX on both sides. A horizontal double-headed arrow between the origin and the IMAX marks on the horizontal axis is labeled DEADBAND, with a 19° angle indicated below it.</p>	<p>The 5A control controls displacement in proportion to an electric current between zero and 350 milliamps. The control is available with or without a 10% deadband. Positive polarity drives the control in one direction, and negative polarity in the other. Adjustable maximum displacement stops are included. The 5C option, with automatic brake control, is also available.</p>
 <p>The graph plots CAM ANGLE on the vertical axis against P MAX on the horizontal axis. A dashed diagonal line represents the ideal relationship. A horizontal line is drawn at a CAM ANGLE of 19°. Vertical lines from the intersection of this horizontal line and the dashed line drop to the horizontal axis, marking P MAX on both sides. A horizontal double-headed arrow between the origin and the P MAX marks on the horizontal axis is labeled DEADBAND, with a 19° angle indicated below it.</p>	<p>The 8A control controls displacement in proportion to a hydraulic pressure, values listed below. The control is available with or without a 10% deadband. Pressure applied in the P1 port drives the pump on stroke in one direction, P2 port in the other. Adjustable maximum displacement stops are included. The 8C option, with automatic brake control, is also available.</p>

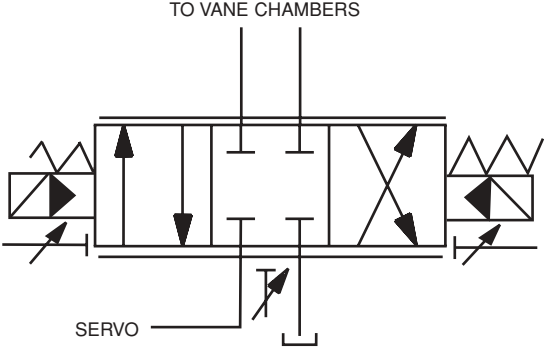
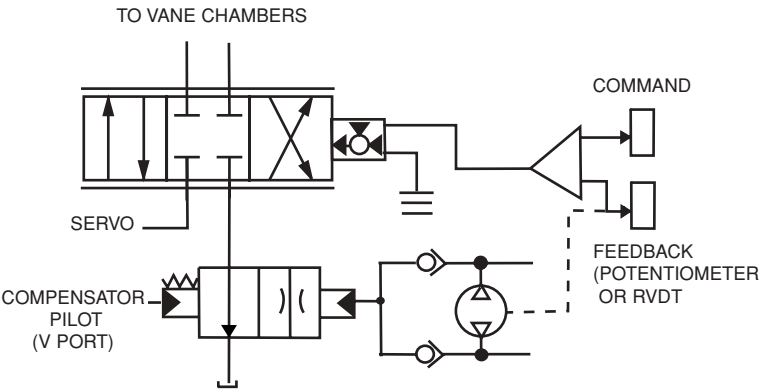
CODE	DESCRIPTION	HYDRAULIC CIRCUIT
9A	ELECTRIC STROKER	
7D6 7D8 7F6 7F8	HIGH IQ SERVOVALVE CONTROL	

TYPICAL PERFORMANCE

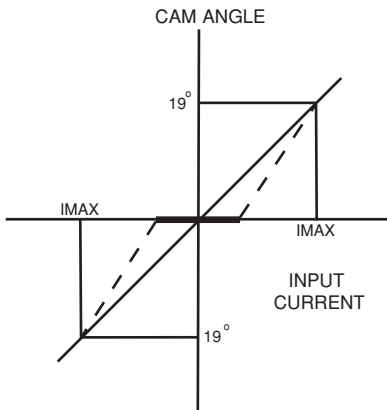

DESCRIPTION OF OPERATION

The 9A control controls displacement in proportion to an electric current between zero and 350 milliamps for the 24 volt version, and up to 650 milliamps for the 12 volt version. The control is available with or without a 10% deadband. The control signal is a Pulse Width Modulated signal. Current signal to one coil drives the pump in one direction, and to the other coil in the opposite. Adjustable maximum displacement stops are included. The 9C option, with automatic brake control, is also available.

Specifications:	
Hysteresis	5% typical, 8% maximum
Linearity	8%
Response	P6,7,8 0.9 seconds, zero to full stroke or back P11,14 1.5 seconds, zero to full stroke or back P24, 30 1.8 seconds, zero to full stroke or back
Repeatability	2%
Temperature null shift	<2% per 100°F (38° C)
Servo pressure required	200-1000 psi (14-70 bar), 400 nominal (28 bar)
Coil resistance	41 ohms
Electrical input	270 ma minimum, 325 ma nominal, 350 ma maximum
Neutral deadband	150 ma minimum, 180 ma nominal, 210 ma maximum
Manual override	3/16" Allen wrench, 30 in-lb (3.4Nm) with zero signal
Fluid types	All
Fluid cleanliness	Contains a 75 micron filter, NAS 1638, class 8 or ISO 17/14
Available drivers	5A Driver 020-14078-0 5A options card S20-11716-0
	Power supply 762-30026-0
	Euro card holder 701-00007-8
Electrical connector	DIN 43650 type AF, 16-01008-8
Fluid cleanliness	NAS 1638, class 8 or ISO 17/14

CAM ANGLE

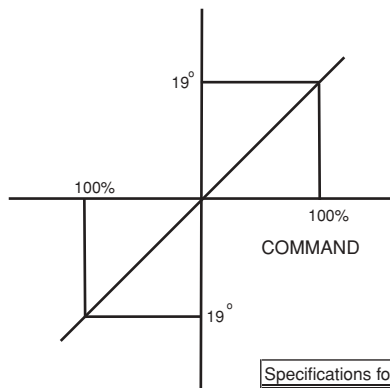

The 7** control is a high response displacement control that uses a servovalve to direct high flow levels to and from the vane chambers, in order to achieve high stroke rates on the pump. A feedback potentiometer or RVDT (Rotary Variable Differential Transformer) is used to feed back the rocker cam position to the controlling electronics to achieve stable operation.

The 7D6 control uses a servovalve and a feedback potentiometer for feedback, the 7D8 uses an RVDT.

The 7F6 control uses servovalve and a the feedback potentiometer, but also has a special valve block with a valve in it to shut off the servovalve, so that control may be taken over by a 4A2 control also mounted to the pump as a manual override. The 7F8 is the same, except using an RVDT.

Specifications for 7D,7F:			
	P6,7,8	P11,14	P24/30
Hysteresis	<±1%	<±1%	±1%
Linearity	<±0.5%	<±0.5%	±0.5%
Step Response	180ms	300 Ms	360 Ms
Small Signal Frequency Response	10 Hz, 400 psi (28 bar)	8.2 Hz., 440 psi (30 bar)	6 Hz., 500 psi (35 bar)
	17 Hz., 1000psi (70 bar)	13 Hz., 1000 psi (70 bar)	9 Hz., 1000 psi (70 bar)
Servo Pressure	1000 psi (70 bar) nominal		
Coil Resistance	1000 ohms		
Electrical Input	0-10 ma		
Feedback Pot Output,	±3 VDC		
19°, 15 VDC excitation			
Feedback RVDT Output,	±2.4 VDC		
19°, 15 VDC excitation			
Fluid Types	All		
Fluid Cleanliness	NAS 1638, class8 or ISO 17/14		
Available Drivers	Jupiter High IQ S20-11958		
Electrical Connector			

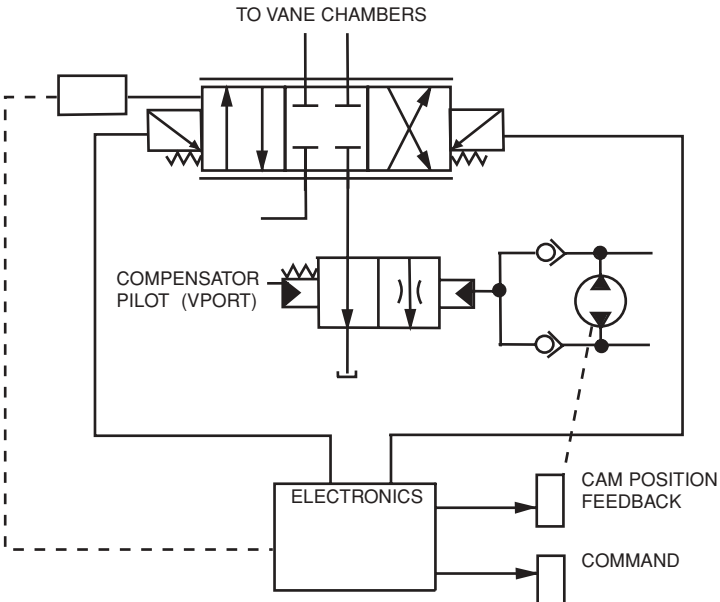
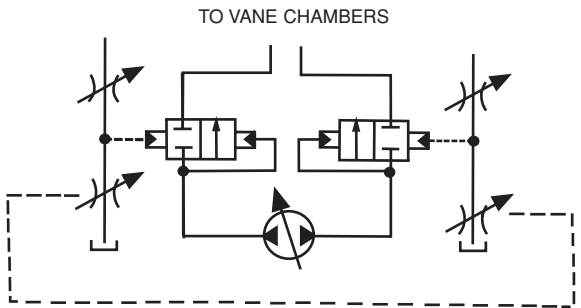
CODE	DESCRIPTION	HYDRAULIC CIRCUIT
<p>7J6 7J8 7K6 7K8</p>	<p>HIGH IQ 4DCO1 CONTROL PROPORTIONAL VALVE</p>	 <p>TO VANE CHAMBERS</p> <p>COMPENSATOR PILOT (VPORT)</p> <p>ELECTRONICS</p> <p>CAM POSITION FEEDBACK</p> <p>COMMAND</p>
<p>--4</p>	<p>TORQUE LIMITER OVERRIDE</p>	 <p>TO VANE CHAMBERS</p>

TYPICAL PERFORMANCE

DESCRIPTION OF OPERATION

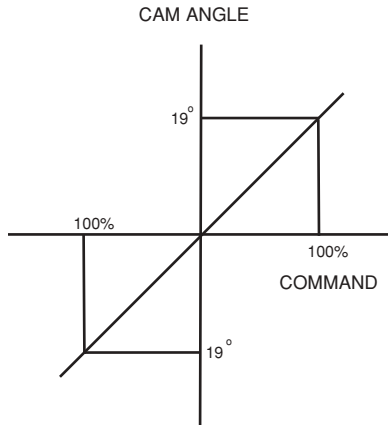

The 700 controls are high response displacement controls that use proportional directional flow control valves to direct high flow levels to and from the vane chambers, in order to achieve high stroke rates on the pump. A feedback potentiometer or RVDT (Rotary Variable Differential Transformer) is used to feed back the rocker cam position to the controlling electronics to achieve stable operation.

The 7J6 control uses a proportional directional control valve and a feedback potentiometer for feedback, the 7J8 uses an RVDT.

The 7K6 control uses proportional directional control valve and a feedback potentiometer, but also has a special valve block with a valve in it to shut off the servovalve, so that control may be taken over by a 4A2 control also mounted to the pump as a manual override. The 7K8 is the same, except using an RVDT.

Specifications for 7J, 7K			
	P6,7,8	P11,14	P24/30
Hysteresis	<±1%	<±1%	<±1%
Linearity	<±0.9%	<±0.9%	±0.9%
Step Response	180 ms	300 ms	300 ms
Small Signal Frequency Response	16 Hz, 400 psi (28 bar)	12 Hz, 440 psi (30 bar)	8Hz, 500 psi (35 bar)
	25 Hz, 1000 psi (70 bar)	20 Hz, 1000 psi (70 bar)	10 Hz, 1000 psi (70 bar)
Servo Pressure	1000 psi (70 bar) nominal		
Coil Resistance	1000 ohms		
Electrical Input	0-10 ma		
Feedback Pot Output	±3 VDC at 19°, 15 VDC excitation		
Feedback RVDT Output,	±2.4 VDC at 19°, 15 VDC excitation		
Fluid Types	All		
Fluid Cleanliness	NAS 1638, class 8 or ISO 17/14		
Available Drivers	Jupiter High IQ driver S20-11958		
Electrical Connector			

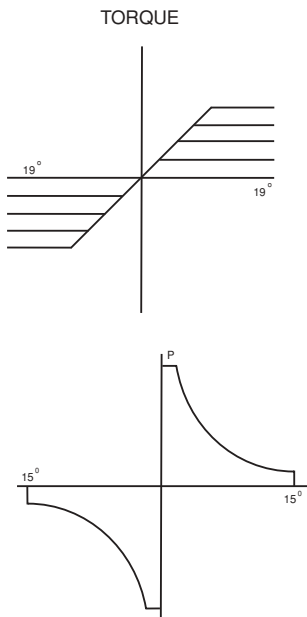

The **4 control option can be added to any other control, except the 7**, and will limit the amount of torque accepted by the drive shaft on the pump by reducing displacement if the product of pressure and flow (displacement) exceed a preset value. This will allow the pump to go to full stroke, but not at maximum pressure, and it will allow the pump to go to full pressure, but not at maximum flow. When the condition causing the overload disappears, the pump control reverts to the main displacement control. The pressure compensator override is always in effect, at all times, and its function is not effected by this control in any way.

Series 6, 7 & 8 Information

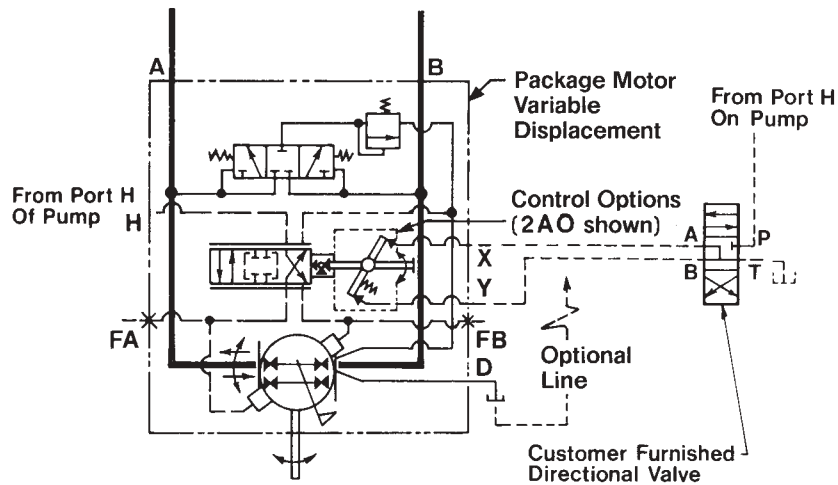
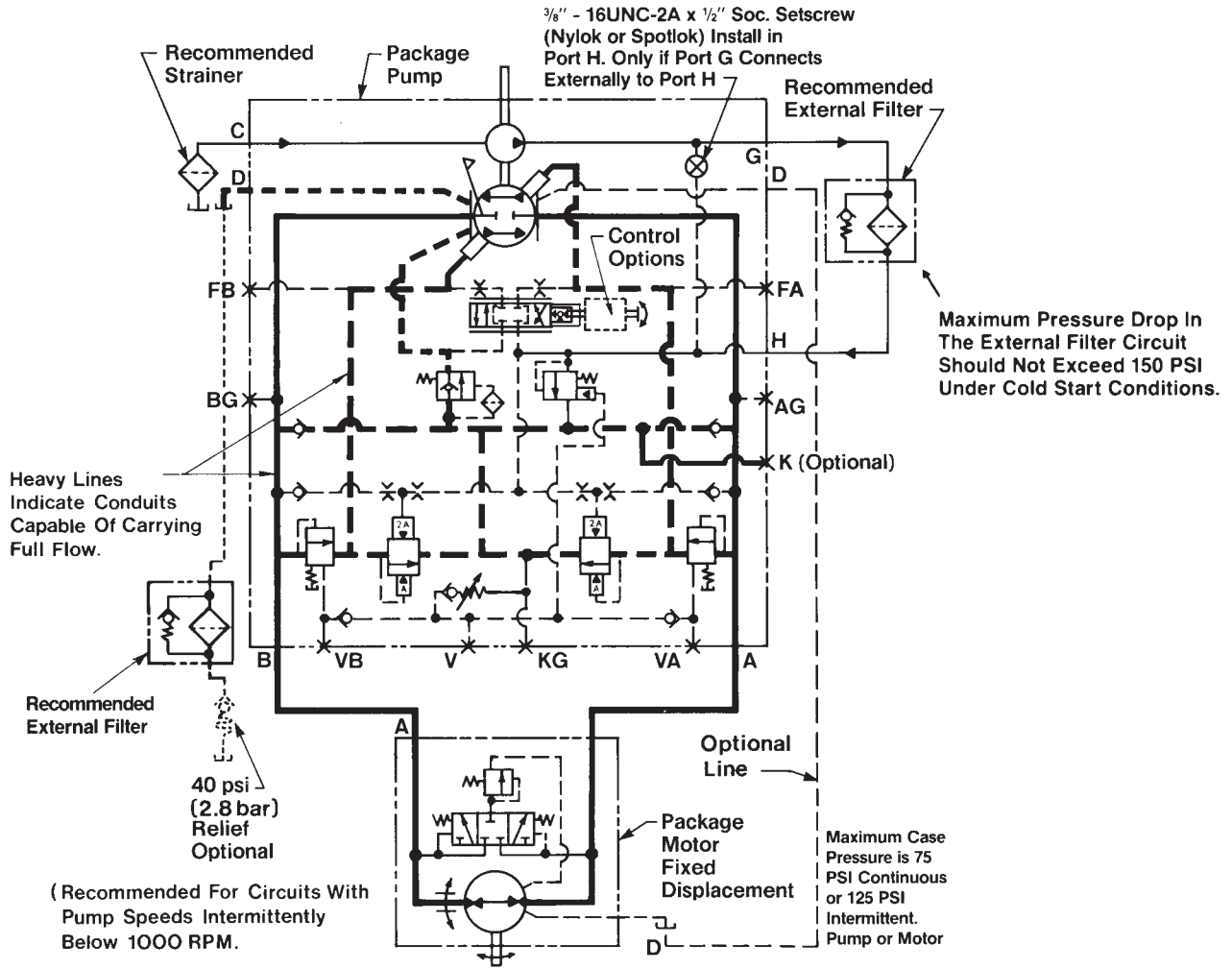

Series 11 & 14 Information

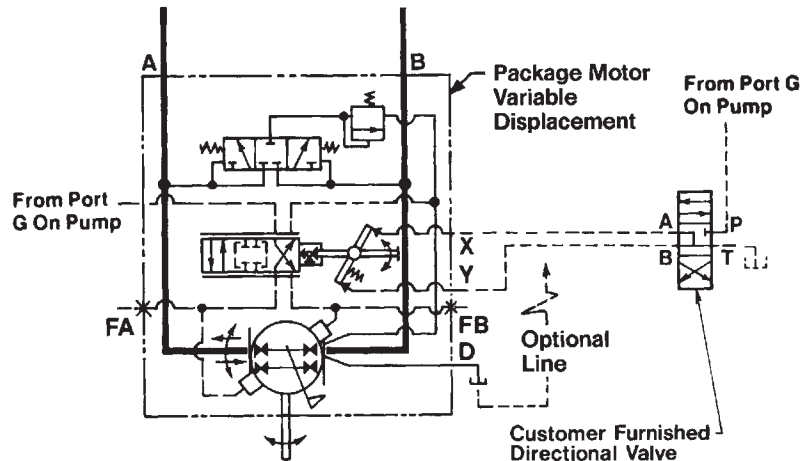
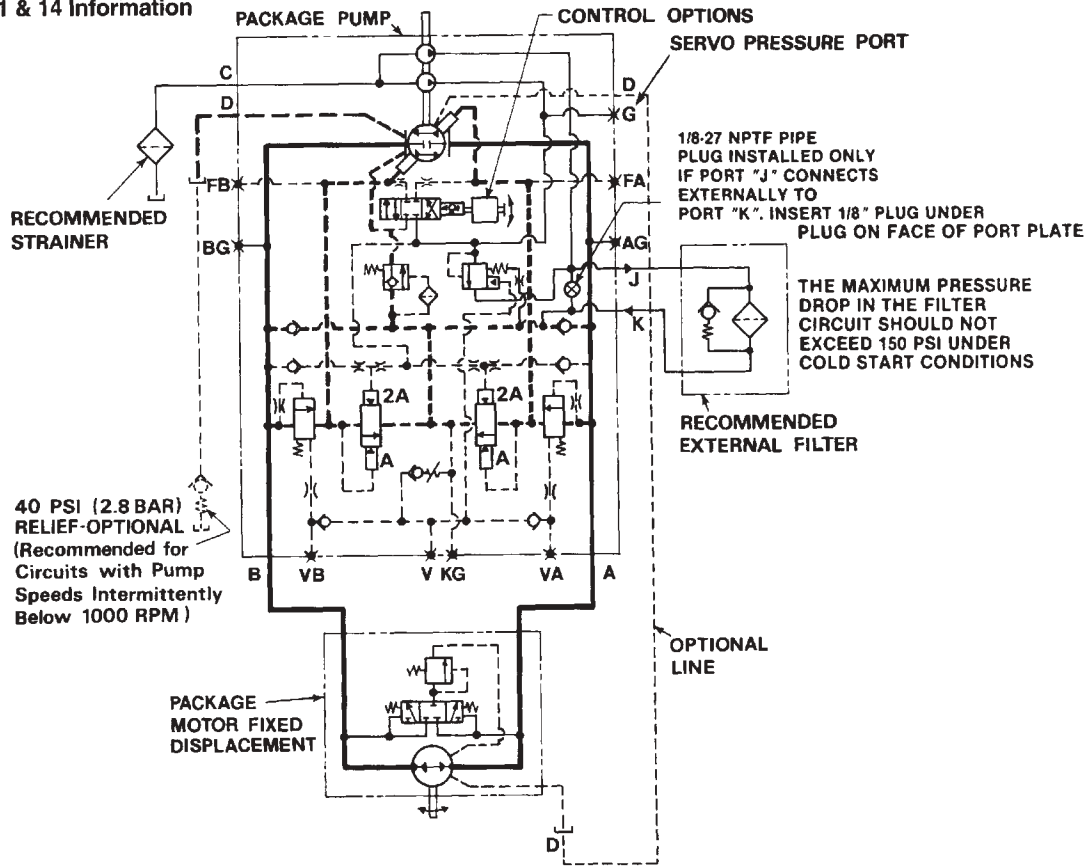

NOTE:
 Servo pressure must be furnished from Port G of pump to Port H1 or H2 of motor.

Series 24 & 30 Information

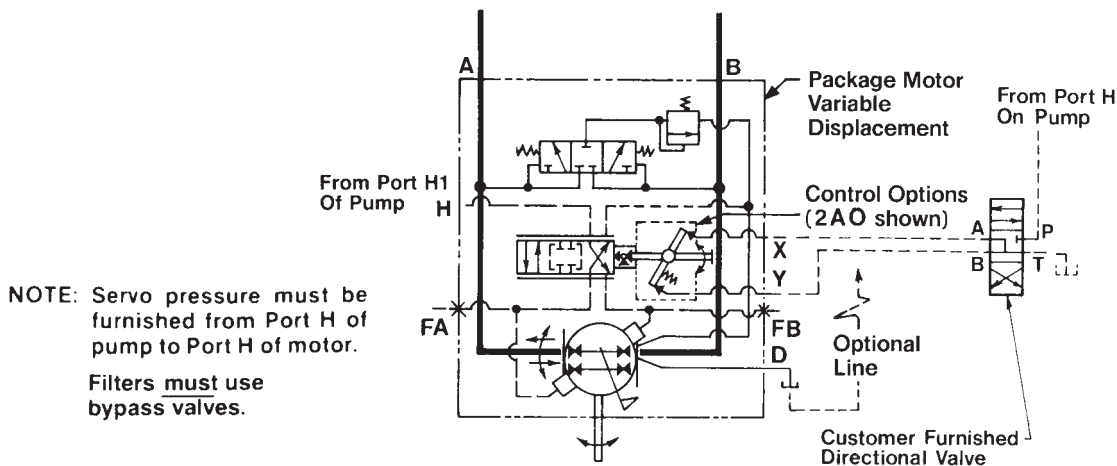
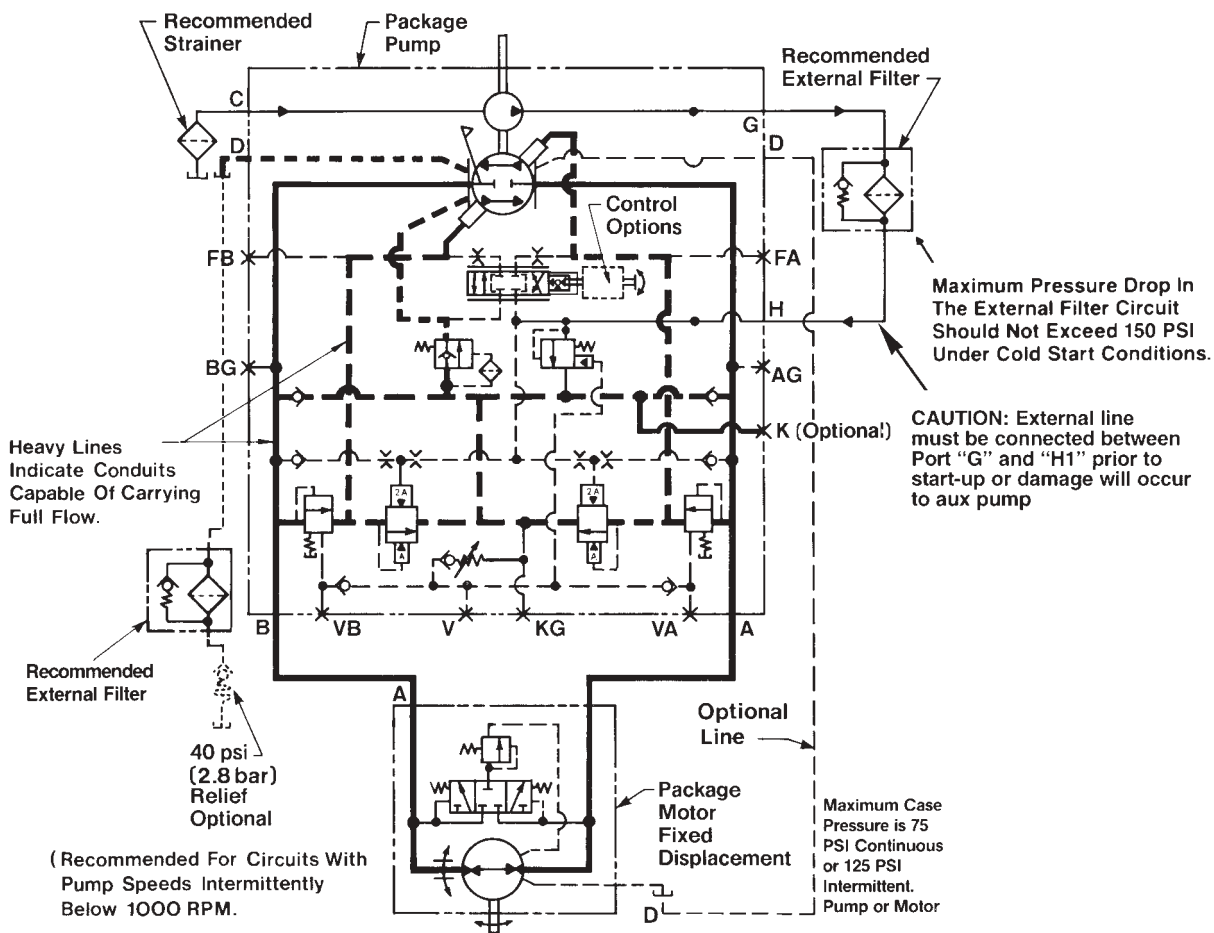

SERIES 6 & 7 INFORMATION

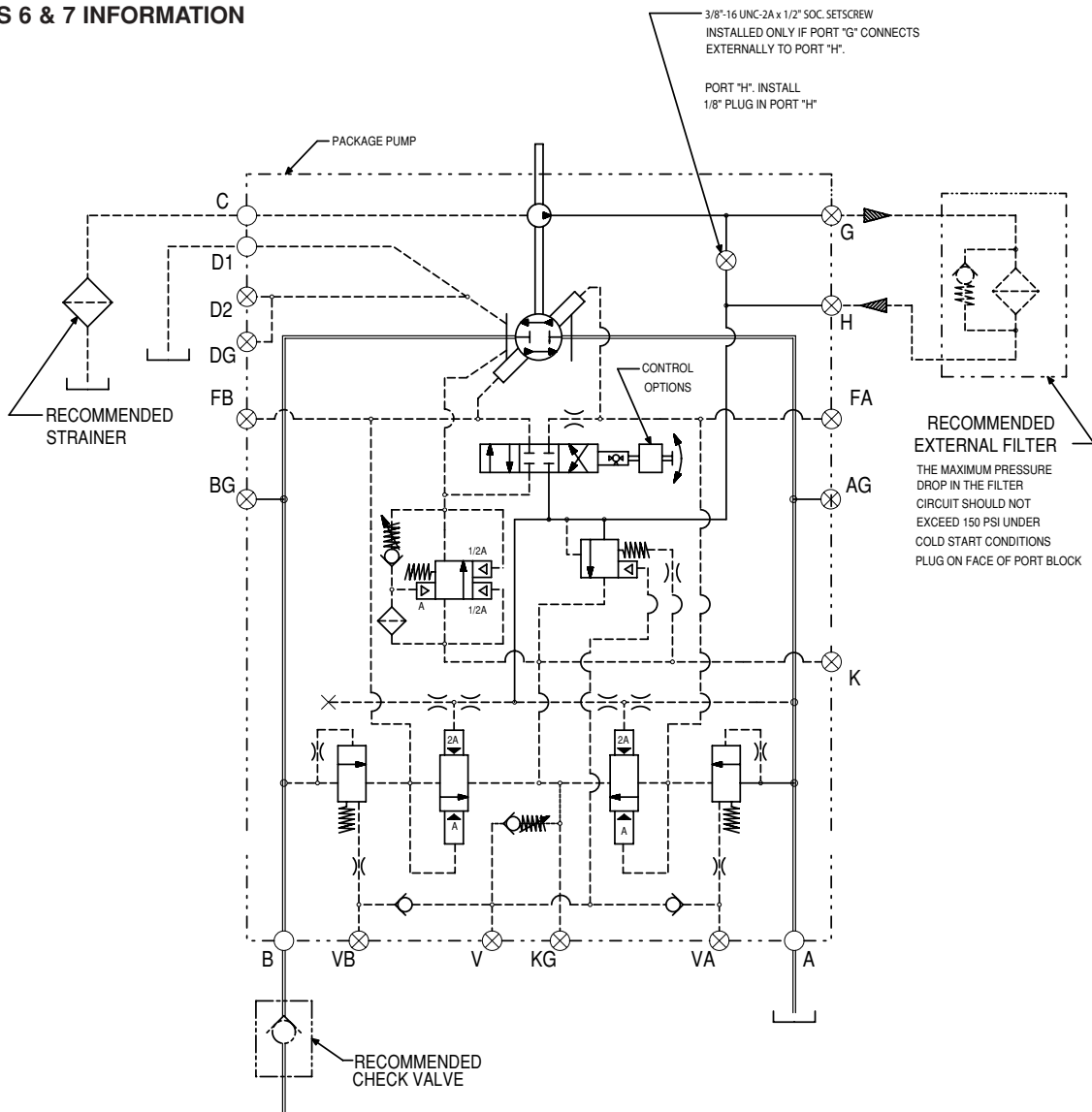

SERIES 6, 7, 8 OPEN CIRCUIT PUMP

	pump rotation	rotary servo input shaft rotation	port "A"	port "B"
input command "A" side	R	CW	inlet	outlet
	L	CCW	inlet	outlet
input command "B" side	R	CCW	inlet	outlet
	L	CW	inlet	outlet

NOTES:

1. The auxiliary pump inlet must be connected directly to the reservoir. See page 39 for main pump and auxiliary pump inlet requirements.
2. Case pressure must not exceed inlet pressure by more than 25 psi, 1,7 bar.
3. Maximum allowable inlet (port C) pressure: 200 psi, 13,8 bar.
4. Filters must use bypass valves.
5. Absolute inlet pressure must be increased for the following fluids:
 - a. 25% for water glycols
 - b. 35% for phosphate esters
6. A check valve in the outlet line between the pump and load is highly recommended where hoses, accumulators or other components may decompress when pump is vented by the compensator.

SERIES 11 & 14 INFORMATION

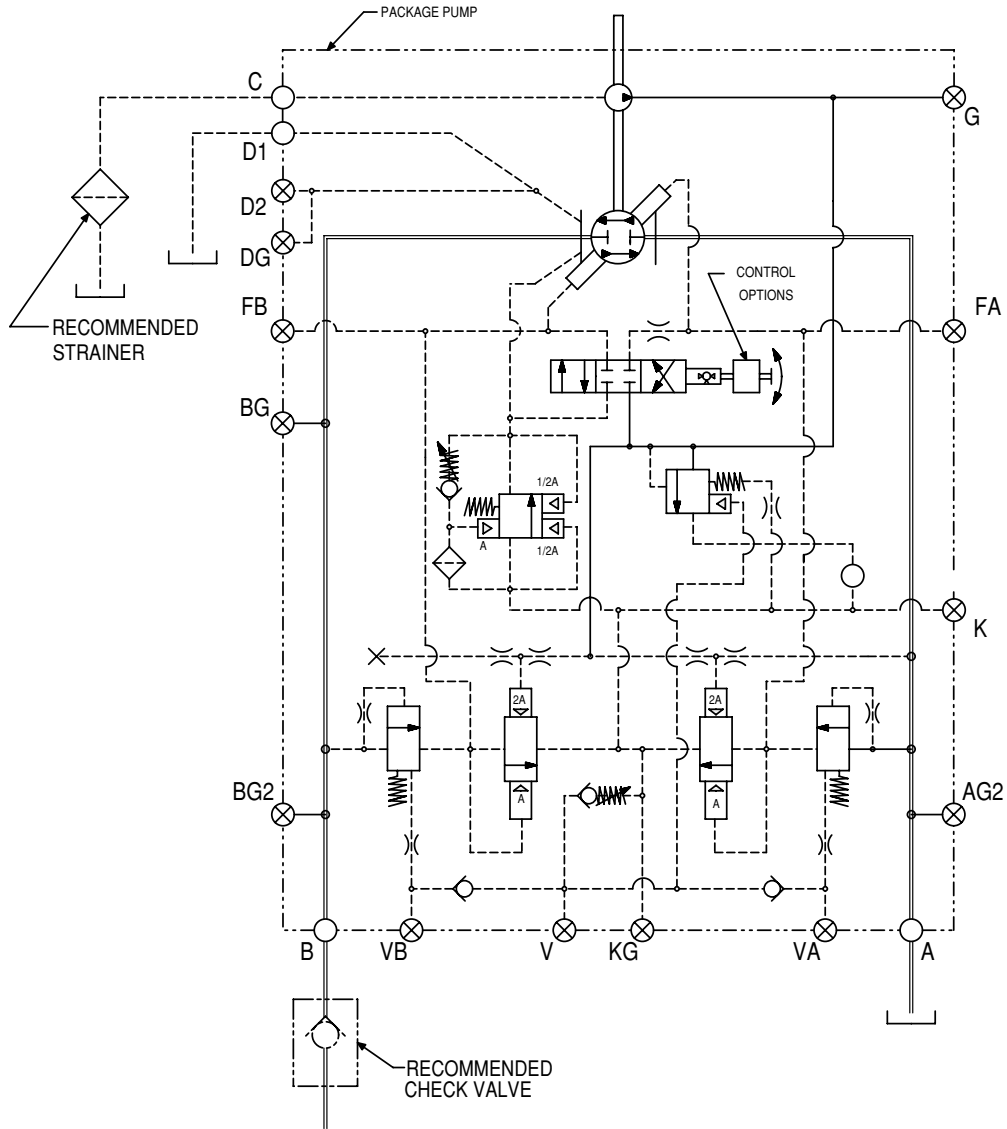

SERIES 11, 14 OPEN CIRCUIT PUMP

	pump rotation	rotary servo input shaft rotation	port "A"	port "B"
input command "A" side	R	CW	inlet	outlet
	L	CCW	inlet	outlet
input command "B" side	R	CCW	inlet	outlet
	L	CW	inlet	outlet

NOTE:

A check valve in the outlet line between the pump and load is highly recommended where hoses, accumulators or other components may decompress when pump is vented by the compensator.

Gold Cup pumps

Model number sheet

Example model code:

	P	11	P			-2	R	1	*	-40	2	-B	00	-0	B	0		
Pump	P																	
Displacement																		
6.00 cu.in./rev. (98 cc/rev.)		6																
7.25 cu.in./rev. (119 cc/rev.)		7																
8.00 cu.in./rev. (131 cc/rev.)		8																
11.0 cu.in./rev. (180 cc/rev.)		11																
14.0 cu.in./rev. (229 cc/rev.)		14																
24.6 cu.in./rev. (403 cc/rev.)		24																
30.6 cu.in./rev. (501 cc/rev.)		30																
Type																		
Fixed displacement, closed circuit			F															
Fixed displacement with high torque thru-drive, closed circuit			M															
Variable displacement, closed circuit			P															
Variable displacement with medium torque thru-drive, closed circuit			X															
Variable displacement with medium torque thru-drive & shuttle package, closed circuit			S															
Variable displacement with high torque thru-drive, closed circuit			R															
Variable displacement with high torque thru-drive & shuttle package, closed circuit			L															
Variable displacement, open circuit (for P6, 7, 8, 11, & 14 only)			V															
Variable displacement, open & closed circuit (for P6, 7, & 8 only)			D															
Efficiency																		
High efficiency (for P24 only)			H															
Standard efficiency			leave blank															
Shaft																		
Keyed SAE - mechanical shaft seal (single lip seal on P6/7/8F/M)						-2 or -02												
Splined SAE - mechanical shaft seal (single lip seal on P6/7/8F/M)						-3 or -03												
Keyed SAE-D (mounting & shaft) - mechanical shaft seal (for P6/7/8 only)(single lip seal on P6/7/8F/M)						-4 or -04												
Splined SAE-D (mounting & shaft) - mechanical shaft seal (for P6/7/8 only)(single lip seal on P6/7/8F/M)						-5 or -05												
Keyed SAE - double lip shaft seal						-7 or -07												
Splined SAE - double lip shaft seal						-8 or -08												
Keyed (long) SAE - double lip shaft seal						-9 or -09												
Keyed (long) SAE - mechanical shaft seal						-10												
Rotation																		
Clockwise							R											
Counter-clockwise							L											
Seals																		
Nitrile (Buna N)								1										
EPR (not available when using "5A" or "5C" primary controls)(pump will be unpainted unless otherwise specified)								4										
Flourocarbon (Viton)								5										
Design letter (assigned by manufacturer)									*									
Primary controls																		
None (for fixed displacement units only)																	omit	
Screw adjustment (spring offset to maximum displacement)																		-10
Cylinder control w/ adjustable maximum volume stops																		-2A
Cylinder control - 3 position (spring centered with zero adjustment)																		-2H
Cylinder control - 2 position electro-hydraulic w/ adjustable maximum volume stop (spring offset to maximum displacement)																		-2M
Cylinder control - 3 position (spring centered) electro-hydraulic																		-2N
Rotary servo - spring centered																		-40
Rotary servo - spring centered w/ adjustable maximum volume stops																		-4A
Rotary servo - spring centered w/ automatic brake control																		-4B
Rotary servo - spring centered w/ adjustable maximum volume stops & automatic brake control																		-4C
Electro-hydraulic stroker w/ adjustable maximum volume stops																		-5A
Electro-hydraulic stroker w/ adjustable maximum volume stops & automatic brake control																		-5C
High IQ with 10 gpm servovalve & volume indicator																		-7D
High IQ with 10 gpm servovalve & 4A (rotary servo) control																		-7F
High IQ with 4DC01 valve & volume indicator																		-7J
High IQ with 4DC01 valve & 4A (rotary servo) control																		-7K
Hydraulic stroker w/ adjustable maximum volume stops																		-8A
Hydraulic stroker w/ adjustable maximum volume stops & automatic brake control																		-8C
Electro-hydraulic stroker w/ adjustable maximum volume stops																		-9A
Electro-hydraulic stroker w/ adjustable maximum volume stops & automatic brake control																		-9C
Secondary controls																		
None (for fixed displacement units only)																		omit
Volume indicator																		2
Torque limiter & volume indicator																		4
Cam position feedback potentiometer																		6
Cam position feedback RVDT (DC)																		8
Control location																		
None (for fixed displacement units only)																		omit
Primary control on port A side																		-A
Primary control on port B side																		-B

Gold Cup pumps													Model number sheet															
Example model code:													P	11	P			-2	R	1	*	-40	2	-B	00	-0	B	0
Control and displacement features																												
2M* & 2N* controls																												
4D01 valve, 110VAC/60Hz with Hirschmann connector													00															
4D01 valve, 12VDC with Hirschmann connector													01															
4D01 valve, 240VAC/50Hz with Hirschmann connector													02															
4D01 valve, 110VAC/60Hz, wiring box													03															
4D01 valve, 12VDC, wiring box													04															
Cetop3 (D03)(NG6) interface, no directional valve													05															
4D01 valve, 24VDC with Hirschmann connector													06															
4D01 valve, 110VAC/50Hz with Hirschmann connector													07															
5** controls																												
with deadband													00															
without deadband													01															
7** controls																												
without manual override shutoff													00															
with manual override shutoff (required for F, G, L & K primary options)													01															
8** controls																												
75 - 350 psi (5 - 24 bar)													00															
75 - 435 psi (5 - 30 bar)													01															
100 - 380 psi (7 - 26 bar)													02															
150 - 400 psi (10 - 28 bar)													03															
75 - 250 psi (5 - 17 bar)													04															
9** controls																												
24VDC													00															
12VDC													01															
All other controls													00															
Reduced displacement options for P*F & P*M																												
Standard cam (19-degree)													00															
P6 with 17-degree cam {5.3 cu.in./rev. (87 cc/rev.)}													10															
P7 with 17-degree cam {6.4 cu.in./rev. (105 cc/rev.)}													10															
P8 with 17-degree cam {7.1 cu.in./rev. (116 cc/rev.)}													10															
P6 with 15-degree cam {4.6 cu.in./rev. (76 cc/rev.)}													20															
P7 with 15-degree cam {5.6 cu.in./rev. (92 cc/rev.)}													20															
P8 with 15-degree cam {6.2 cu.in./rev. (102 cc/rev.)}													20															
P6 with 13-degree cam {4.0 cu.in./rev. (66 cc/rev.)}													30															
P7 with 13-degree cam {4.8 cu.in./rev. (79 cc/rev.)}													30															
P8 with 13-degree cam {5.3 cu.in./rev. (88 cc/rev.)}													30															
P11 with 17-degree cam {9.7 cu.in./rev. (160 cc/rev.)}													10															
P14 with 17-degree cam {12.5 cu.in./rev. (205 cc/rev.)}													10															
P11 with 15-degree cam {8.5 cu.in./rev. (140 cc/rev.)}													20															
P14 with 15-degree cam {10.9 cu.in./rev. (179 cc/rev.)}													20															
P24 with 17-degree cam {22.0 cu.in./rev. (360 cc/rev.)}													10															
P30 with 17-degree cam {27.2 cu.in./rev. (446 cc/rev.)}													10															
Internal pump																												
1.07 cu.in./rev. (17.5 cc/rev.) (P6/7/8P/S/X/N/D & P11/14V only)													-0 (omit if no external drive is required)															
2.14 cu.in./rev. (35 cc/rev.) (P11/14P/S/X only)													-0 (omit if no external drive is required)															
2.81 cu.in./rev. (46 cc/rev.) (P24/30P/S/X only) (standard)													-0 (omit if no external drive is required)															
1.61 cu.in./rev. (26.4 cc/rev.) (P24/30P/S/X only) (auxiliary external replenishing flow required)													-1															
1.05 cu.in./rev. (17.2 cc/rev.) (P24/30P/S/X only) (auxiliary external replenishing flow required)													-2															
3.56 cu.in./rev. (58.3 cc/rev.) (P24/30P/S/X only)													-3															
4.84 cu.in./rev. (79.3 cc/rev.) (P24/30P/S/X only)													-4															
5.42 cu.in./rev. (88.8 cc/rev.) (P24/30P/S/X only)													-5															
6.10 cu.in./rev. (100.0 cc/rev.) (P24/30P/S/X only)													-6															
No internal pump (standard on P*R/L/F/M)													-X															
External drive																												
None													omit															
Blanking plate (for P6/7/8/11/14S/X only)													M															
SAE-A (SAE 82-2)(P6/7/8/11/14S/X/R/L/M only)													A															
SAE-B (SAE 101-2 for P6/7/8S/X/R/L/M & P11/14/24/30S/X)(SAE 101-2 & SAE 101-4 for P11/14/24/30R/L/M)													B															
SAE-C (SAE 127-2 for P6/7/8R/L/M & P24/30S/X)(SAE 127-2 & SAE 127-4 for P11/14/24/30R/L/M)													C															
SAE-D (SAE 152-4)(P11/14/24/30R/L/M only)													D															
SAE-E (SAE 165-4)(P11/14/24/30R/L/M only)													E															
SAE-F (SAE 177-4)(P24/30R/L/M only)													F															
External mounting																												
No external pump mounted													0 (omit if no external drive is required)															
External pump mounted (requires special modification "-M2")(must be separately specified)													1															
Special modification																												
None													omit															
No paint													-NP															
Other special modification (example: bronze caged barrel bearing for low viscosity fluids, tandem pumps, etc.)													-M2															

GOLD CUP PUMP CONTROL COMBINATIONS

102	2M2 *00	2N2 *00	402	5A2 *00	7D6 *00	8A2 *00	8C2 *00	9A2 *00
104	2M2 *01	2N2 *01	404	5A2 *01	7D6 *01	8A2 *01	8C2 *01	9A2 *01
106	2M2 *02	2N2 *02	406			8A2 *02	8C2 *02	
107	2M2 *03	2N2 *03	407	5A4 *00	7D7 *00	8A2 *03	8C2 *03	9A4 *00
108	2M2 *04	2N2 *04	408	5A4 *01	7D7 *01	8A2 *04		9A4 *01
	2M2 *05	2N2 *05					8C4 *00	
2A2	2M2 *06	2N2 *06	4A2	5A6 *00	7D8 *00	8A4 *00	8C4 *01	9A6 *00
2A4	2M2 *07	2N2 *07	4A4	5A6 *01	7D8 *01	8A4 *01	8C4 *02	9A6 *01
2A6			4A6			8A4 *02	8C4 *03	
2A7	2M4 *00	2N4 *00	4A7	5A7 *00	7F6 *01	8A4 *03		9A7 *00
2A8	2M4 *01	2N4 *01	4A8	5A7 *01	7F7 *01	8A4 *04	8C6 *00	9A7 *01
	2M4 *02	2N4 *02			7F8 *01		8C6 *01	
2H2	2M4 *03	2N4 *03	4B2	5A8 *00		8A6 *00	8C6 *02	9A8 *00
2H4	2M4 *04	2N4 *04	4B4	5A8 *01	7J6 *00	8A6 *01	8C6 *03	9A8 *01
2H6	2M4 *05	2N4 *05	4B6		7J6 *01	8A6 *02		
2H7	2M4 *06	2N4 *06	4B7	5C2 *00		8A6 *03	8C7 *00	9C2 *00
2H8	2M4 *07	2N4 *07	4B8	5C2 *01	7J7 *00	8A6 *04	8C7 *01	9C2 *01
					7J7 *01		8C7 *02	
	2M6 *00	2N6 *00	4C2	5C4 *00		8A7 *00	8C7 *03	9C4 *00
	2M6 *01	2N6 *01	4C4	5C4 *01	7J8 *00	8A7 *01		9C4 *01
	2M6 *02	2N6 *02	4C6		7J8 *01	8A7 *02	8C8 *00	
	2M6 *03	2N6 *03	4C7	5C6 *00		8A7 *03	8C8 *01	9C6 *00
	2M6 *04	2N6 *04	4C8	5C6 *01	7K6 *01	8A7 *04	8C8 *02	9C6 *01
	2M6 *05	2N6 *05			7K7 *01		8C8 *03	
	2M6 *06	2N6 *06		5C7 *00	7K8 *01	8A8 *00		9C7 *00
	2M6 *07	2N6 *07		5C7 *01		8A8 *01		9C7 *01
						8A8 *02		
	2M7 *00	2N7 *00		5C8 *00		8A8 *03		9C8 *00
	2M7 *01	2N7 *01		5C8 *01		8A8 *04		9C8 *01
	2M7 *02	2N7 *02						
	2M7 *03	2N7 *03						
	2M7 *04	2N7 *04						
	2M7 *05	2N7 *05						
	2M7 *06	2N7 *06						
	2M7 *07	2N7 *07						
	2M8 *00	2N8 *00						
	2M8 *01	2N8 *01						
	2M8 *02	2N8 *02						
	2M8 *03	2N8 *03						
	2M8 *04	2N8 *04						
	2M8 *05	2N8 *05						
	2M8 *06	2N8 *06						
	2M8 *07	2N8 *07						

- Unless otherwise specified on purchase order, the following **factory setting** will be used.
 Maximum Stop: Full Displacement
 Minimum Stop: Zero Displacement
 Pressure Compensator Override: 1000 psi nominal
 Torque Limiter (**4): P6 @ 1800 rpm = 60 hp nominal
 P7 @ 1800 rpm = 72.5 hp nominal
 P8 @ 1800 rpm = 80 hp nominal
 P11 @ 1800 rpm = 110 hp nominal
 P14 @ 1800 rpm = 140 hp nominal
 P24 @ 1800 rpm = 240 hp nominal
 P30 @ 1800 rpm = 300 hp nominal

Gold Cup motors		Model number sheet														
Example model code:		M	11	R		-2	N	1	*	-9A	5	-B	0	0	-B	0
Motor	M															
Displacement																
6.00 cu.in./rev. (98 cc/rev.)	6															
7.25 cu.in./rev. (119 cc/rev.)	7															
8.00 cu.in./rev. (131 cc/rev.)	8															
11.0 cu.in./rev. (180 cc/rev.)	11															
14.0 cu.in./rev. (229 cc/rev.)	14															
24.6 cu.in./rev. (403 cc/rev.)	24															
30.6 cu.in./rev. (501 cc/rev.)	30															
Type																
Fixed displacement	F															
Fixed displacement with shuttle package	G															
Fixed displacement with thru-drive	M															
Fixed displacement with thru-drive & shuttle package	N															
Variable displacement	V															
Variable displacement with shuttle package	H															
Variable displacement with thru-drive	R															
Variable displacement with thru-drive & shuttle package	L															
Efficiency																
High efficiency (for M24 only)	H															
Standard efficiency	leave blank															
Shaft																
Keyed SAE - mechanical shaft seal (single lip seal on M6/7/8F/G/M/N)	-2 or -02															
Splined SAE - mechanical shaft seal (single lip seal on M6/7/8F/G/M/N)	-3 or -03															
Keyed SAE-D (mounting & shaft) - mechanical shaft seal (for M6/7/8 only)(single lip seal on M6/7/8F/G/M/N)	-4 or -04															
Splined SAE-D (mounting & shaft) - mechanical shaft seal (for M6/7/8 only)(single lip seal on M6/7/8F/G/M/N)	-5 or -05															
Keyed SAE - double lip shaft seal	-7 or -07															
Splined SAE - double lip shaft seal	-8 or -08															
Keyed (long) SAE - double lip shaft seal	-9 or -09															
Keyed (long) SAE - mechanical shaft seal	-10															
Rotation																
Bi-directional	N															
Seals																
Nitrile (Buna N)	1															
EPR (not available when using "5A" primary control)(pump will be unpainted unless otherwise specified)	4															
Fluorocarbon (Viton)	5															
Design letter (assigned by manufacturer)									*							
Primary controls																
None (for fixed displacement units only)	omit															
Cylinder control w/ adjustable maximum volume stops	-2A															
Cylinder control - 2 position electro-hydraulic w/ adjustable maximum volume stop (spring offset to maximum displacement)	-2M															
Electro-hydraulic stroker w/ adjustable maximum volume stops	-5A															
Hydraulic stroker w/ adjustable maximum volume stops (required for M24/30 reverse compensator units)	-8A															
Electro-hydraulic stroker w/ adjustable maximum volume stops	-9A															
Secondary controls																
None (for fixed displacement units only)	omit															
Volume indicator	0															
Reverse compensator (spring offset to maximum displacement) + volume indicator	3															
Reverse compensator (spring offset to minimum displacement) + volume indicator	5															
Cam position feedback potentiometer	6															
Cam position feedback RVDT (AC)	7															
Cam position feedback RVDT (DC)	8															
Reverse compensator (3) + cam position feedback potentiometer (6)	U															
Reverse compensator (3) + cam position feedback RVDT (7)	V															
Reverse compensator (3) + cam position feedback RVDT (8)	W															
Reverse compensator (5) + cam position feedback potentiometer (6)	X															
Reverse compensator (5) + cam position feedback RVDT (7)	Y															
Reverse compensator (5) + cam position feedback RVDT (8)	Z															
Control location																
None (for fixed displacement units only)	omit															
Primary control on port A side	-A															
Primary control on port B side	-B															

Gold Cup motors											Model number sheet														
Example model code:											M	11	R		-2	N	1	*	-9A	5	-B	0	0	-B	0
Control and displacement features																									
2M control																									
4D01 valve, 110VAC/60Hz with Hirschmann connector																0									
4D01 valve, 12VDC with Hirschmann connector																1									
4D01 valve, 240VAC/50Hz with Hirschmann connector																2									
4D01 valve, 110VAC/60Hz, wiring box																3									
4D01 valve, 12VDC, wiring box																4									
Cetop3 (D03)(NG6) interface, no directional valve																5									
4D01 valve, 24VDC with Hirschmann connector																6									
4D01 valve, 110VAC/50Hz with Hirschmann connector																7									
5A control																									
with deadband																0									
without deadband																1									
8A control																									
75-250 psi (5-17 bar)																0									
250-450 psi (17-31 bar)																1									
9A control																									
24VDC																0									
12VDC																1									
All other controls																0									
Reduced displacement options for M*F, M*G, M*M, & M*N																									
Standard cam (19-degree)																0									
M6 with 17-degree cam {5.3 cu.in./rev. (87 cc/rev.)}																1									
M7 with 17-degree cam {6.4 cu.in./rev. (105 cc/rev.)}																1									
M8 with 17-degree cam {7.1 cu.in./rev. (116 cc/rev.)}																1									
M6 with 15-degree cam {4.6 cu.in./rev. (76 cc/rev.)}																2									
M7 with 15-degree cam {5.6 cu.in./rev. (92 cc/rev.)}																2									
M8 with 15-degree cam {6.2 cu.in./rev. (102 cc/rev.)}																2									
M6 with 13-degree cam {4.0 cu.in./rev. (66 cc/rev.)}																3									
M7 with 13-degree cam {4.8 cu.in./rev. (79 cc/rev.)}																3									
M8 with 13-degree cam {5.3 cu.in./rev. (88 cc/rev.)}																3									
M11 with 17-degree cam {9.7 cu.in./rev. (160 cc/rev.)}																1									
M14 with 17-degree cam {12.5 cu.in./rev. (205 cc/rev.)}																1									
M11 with 15-degree cam {8.5 cu.in./rev. (140 cc/rev.)}																2									
M14 with 15-degree cam {10.9 cu.in./rev. (179 cc/rev.)}																2									
M24 with 17-degree cam {22.0 cu.in./rev. (360 cc/rev.)}																1									
M30 with 17-degree cam {27.2 cu.in./rev. (446 cc/rev.)}																1									
Shuttle valve features																									
without orifices																0 (omit for M*F/M/V/R units)									
with orifices																2									
External drive																									
None (for M*F/G/V/H units only)																omit									
SAE-A (SAE 82-2)(for M6/7/8/11/14M/N/R/L units only)																-A									
SAE-B (SAE 101-2 for M6/7/8M/N/R/L)(SAE 101-2 & SAE 101-4 for M11/14/24/30M/N/R/L)																-B									
SAE-C (SAE 127-2 for M6/7/8M/N/R/L)(SAE 127-2 & SAE 127-4 for M11/14/24/30M/N/R/L)																-C									
SAE-D (SAE 152-4)(for M11/14/24/30M/N/R/L units only)																-D									
SAE-E (SAE 165-4)(for M11/14/24/30M/N/R/L units only)																-E									
SAE-F (SAE 177-4)(for M24/30M/N/R/L units only)																-F									
External mounting																									
No external motor mounted																0									
External motor mounted (requires special modification "-M2")(must be separately specified)																1									
Special modification																									
None																omit									
No paint																-NP									
Other special modification (example: bronze caged barrel bearing for low viscosity fluids, tandem motors, etc.)																-M2									

GOLD CUP MOTOR CONTROL COMBINATIONS

2A0		*2M3 *0		5A0 *0		8A0 *0		9A0 *0
*2A3		*2M3 *1		5A0 *1		8A0 *1		9A0 *1
*2A5		*2M3 *2						
2A6		*2M3 *3		*5A3 *0		8A3 *0		*9A3 *0
2A7		*2M3 *4		*5A3 *1		8A3 *1		*9A3 *1
2A8		*2M3 *5						
		*2M3 *6		*5A5 *0		8A5 *0		*9A5 *0
2M0 *0		*2M3 *7		*5A5 *1		8A5 *1		*9A5 *1
2M0 *1								
2M0 *2		*2M5 *0		5A6 * 0		8A6 *0		9A6 *0
2M0 *3		*2M5 *1		5A6 *1		8A6 *1		9A6 *1
2M0 *4		*2M5 *2						
2M0 *5		*2M5 *3		5A7 *0		8A7 *0		9A7 *0
2M0 *6		*2M5 *4		5A7 *1		8A7 *1		9A7 *1
2M0 *7		*2M5 *5						
		*2M5 *6		5A8 *0		8A8 *0		9A8 *0
		*2M5 *7		5A8 *1		8A8 *1		9A8 *1
		2M6 *0						
		2M6 *1						
		2M6 *2						
		2M6 *3						
		2M6 *4						
		2M6 *5						
		2M6 *6						
		2M6 *7						
		2M7 *0						
		2M7 *1						
		2M7 *2						
		2M7 *3						
		2M7 *4						
		2M7 *5						
		2M7 *6						
		2M7 *7						
		2M8 *0						
		2M8 *1						
		2M8 *2						
		2M8 *3						
		2M8 *4						
		2M8 *5						
		2M8 *6						
		2M8 *7						

* Not available for M24 or M30

Unless otherwise specified on purchase order, the following **factory setting** will be used.
 Maximum Stop: Full Displacement
 Minimum Stop: Approximately 30% Displacement
 Reverse Pressure Compensator Override (**3 & **5): 1000 psi nominal

Denison Hydraulics Inc

14249 Industrial Parkway
Marysville, OH 43040 USA

Tel : 937-644-3915

Fax : 937-642-3738

E-mail:

denison@denisonhydraulics.com

Call toll-free

800-551-5956

*in North America or
visit*

www.denisonhydraulics.com

to locate a

*Denison representative
nearest you.*

North America**Canada**

Denison Hydraulics Canada Inc.
2880 Brighton Road, Unit 1
Oakville, ON L6H 5S3, Canada
Tel : +1 (905) 829-5800
Fax : +1 (905) 829-5805

Latin America**Mexico, Central America, South America, Caribbean countries**

Denison Hydraulics Inc.
7850 NW 146 Street
Suite 512
Miami Lakes, FL 33016, USA
Tel : +1 (305) 362-2246
Fax : +1 (305) 362-6220

Asia-Pacific**Australia**

Denison Hydraulics PTY
41-43 St Hilliers Road
P.O.Box 192
Auburn N.S.W. 2144, Australia
Tel : +61 (2) 9646 5200
Fax : +61 (2) 9643 1305

Hong Kong

Denison Hydraulics Ltd.
Unit 6A, 33/F Cable TV Tower
9 Hoi Shing Road, Tsuen Wan
NT, Hong Kong
Tel : +852 2498 8381
Fax : +852 2499 1522

Japan

Denison Japan Inc.
4-2-1 Tsujido-Shinmachi
Fujisawa 251-0042, Japan
Tel : +81 (466) 35-3050
Fax : +81 (466) 35-2019

People Republic of China

Shanghai Denison Hydraulics
Engineering Ltd.
Room 8018, No. 601
Zhang Yang Road,
Pudong New Area
Shanghai 200120, P.R. China
Tel : +86 (21) 58205042 / 34
Fax : +86 (21) 58205014

Singapore

Denison Hydraulics PTE LTD
Blk 4012 Ang Mo Kio Ave 10,
Unit #07-01D Techplace I
Singapore 569628
Tel : +65 268 7840
Fax : +65 268 7847

Taiwan

Denison Hydraulics LTD
6F-10, No. 79,
Sec. 2 Roosevelt Rd,
Taipei, Taiwan, ROC
Tel : +886-2-23645101
Fax : +886-2-23639025

Europe**Austria**

Denison Hydraulics GmbH
Zweigniederlassung Linz
Haibachstraße 69
4061 Pasching, Austria
Tel : +43 (72 29) 48 87
Fax : +43 (72 29) 6 30 92

Benelux

Denison Hydraulics Benelux B.V.
Pascalstraat 100
3316 GR Dordrecht, Holland
Tel : +31 (78) 6543 070
Fax : +31 (78) 6175 755

Denmark

Denison Hydraulics Denmark A/S
Industrikrogen 2
2635 Ishøj, Denmark
Tel : +45 (4371) 15 00
Fax : +45 (4371) 15 16

Finland

Denison Lokomec Oy
Polunmäenkatu 22
P.O. Box 116
33721 Tampere, Finland
Tel : + 358 (3) 357 5100
Fax : + 358 (3) 357 5111

France

Denison Hydraulics S.A.
14 route du bois blanc
BP 539
18105 Vierzon, France
Tel : +33 (2) 48 53 01 20
Fax : +33 (2) 48 75 02 91

Great Britain

Denison Hydraulics UK LTD
Kenmore Road
Wakefield 41, Industrial Park
Wakefield, WF2 OXE
West Yorkshire, England
Tel : +44 (1924) 826 021
Fax : +44 (1924) 826 146

Germany

Denison Hydraulics GmbH
Auf dem Sand 14
D 40721 Hilden, Germany
Tel : +49 (0) 2103 / 940-3
Fax : +49 (0) 2103 / 940-558

Italy

Denison Hydraulics Srl
Via Le Europa 68
20090 Cusago (MI), Italy
Tel : +39 (02) 90330-1
Fax : +39 (02) 90390694/5/6
Denison Calzoni S.p.A
Via Caduti di Sabbiano15/17
40011 Anzola dell'Emilia
Bologna, Italy
Tel : +39 (051) 6501611
Fax : +39 (051) 736221

Spain

Denison Hydraulics S.A.
Gomis 1
08023 Barcelona, Spain
Tel : +34 (93) 253 1990
Fax : +34 (93) 211 6507

Sweden

Denison Hydraulics Svenska AB
Sporregatan 13
213 77 - Malmö, Sweden
Tel : +46 (40) 600 13 00
Fax : +46 (40) 600 13 50

Others**Other European, Middle East, African countries**

Denison Hydraulics S.A.
ATTN: Export Office
14 route du bois blanc
BP 538
18105 Vierzon, France
Tel : +33 (2) 48 53 01 20
Fax : +33 (2) 48 53 01 46

For more information, please contact:

DENISON Hydraulics

<http://www.denisonhydraulics.com>